

HOBBY  
ELECTRONICS

From the Publishers of  
Radio-Electronics

\$2.50 U.S.  
WINTER 1985  
\$2.95 CANADA

# Hands-on Electronics



48784

# 3

THE MAGAZINE FOR THE ELECTRONICS ACTIVIST!

## BUDGET ROBOTICS

There are a few robots that you can take home, but you may have to assemble them!

## LOW-COST TEST GEAR

Tips on setting up the beginner's basic test bench will get you more gear per dollars.

## WHAT IS E.M.P.?

Electromagnetic pulse—It can stop your car, destroy your computer and bring a nation to a standstill.

## DIGITAL FUNDAMENTALS

We kick-off with Binary Numbers in our initial basic theory course.

## PLUS PROJECTS—

- Hands-Free Telephone
- Computer RF Modulator
- Stereo Power Meter
- One-Octave Toy Organ
- Tri-Waveform Generator

*Plus*—Articles on Ham Radio, computers, scanners, tools, shortwave, and much more!

## JACOB'S LADDER

Build this project that repeatedly generates a climbing electric arc, and amaze your friends!



A  
GERNEBACK  
PUBLICATION



# Now! Tek quality and expert advice are just a free phone call away!

**100 MHz dual time base scope.** Easy-to-read CRT; bright, full-sized 8x10 cm; 14 kv accelerating potential complete with BEAM FIND; separate A/B dual intensity controls, FOCUS and TRACE ROTATION.

**Wide range vertical sensitivity.** Choose from 2 mV/div (1x probe) to 50 V/div (10x probe); color-keyed for 1x and 10x probes; variable control increases scale factor by 2.5 to 1.

**Two 100 MHz, high sensitivity channels.** 3.5 ns risetime; dc to  $\geq 100$  MHz bandwidth from 5 V/div to 5 mV/div; extended sensitivity of 2 mV/div at  $\geq 90$  MHz.

**A/B sweep selection.** Calibrated A sweeps from 50 ns/div to 0.5 s/div; B sweeps from 50 ns/div to 50 ms/div; variable control for up to 2.5 to 1 reduction and 10x magnification for sweeps to 5 ns/div.

**Dual time base measurements.** Select either A or B sweeps, or both alternately with A intensified by B.

**B trigger slope and level.** Use B trigger level to select B-triggered or run-after-delay modes; use B TRIGGER SLOPE to select transitions.

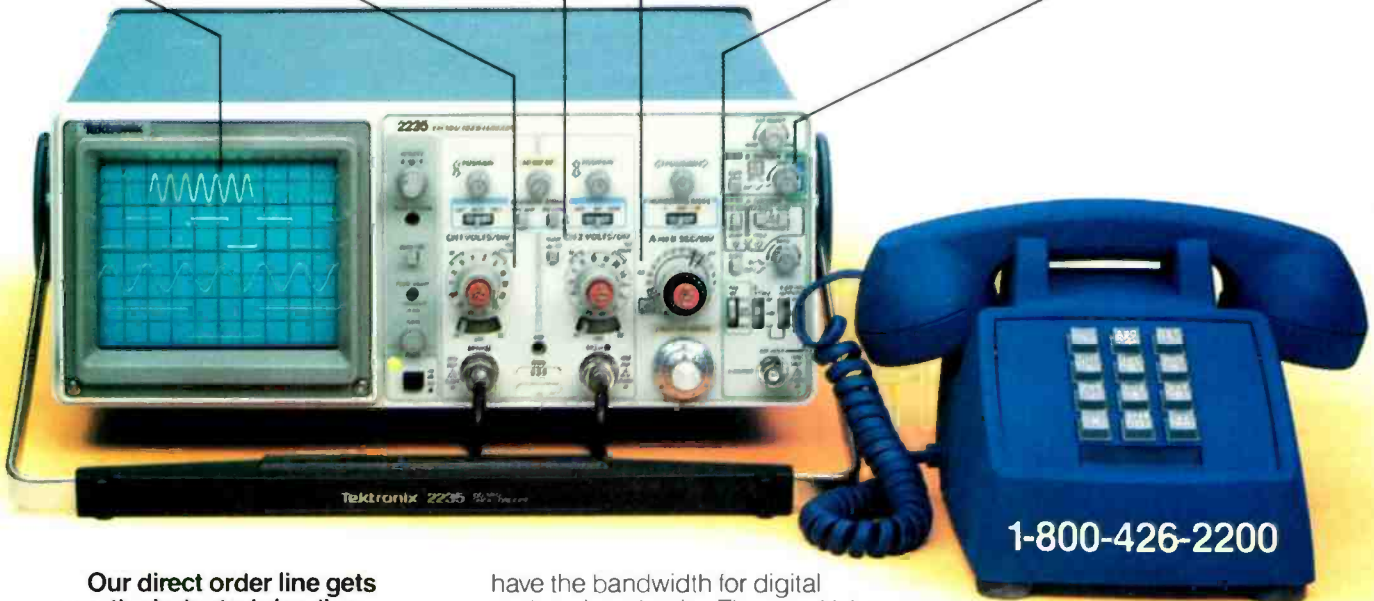

1-800-426-2200

**Our direct order line gets you the industry's leading price/performance portables... and fast answers from experts!** The 60 MHz single time base delay 2213A, the 60 MHz dual time base 2215A and the 100 MHz dual time base 2235 offer unprecedented reliability and affordability, plus the industry's first 3-year warranty\* on labor and parts, CRT included.

**The cost: just \$1200 for the 2213A, \$1450 for the 2215A, \$1650 for the 2235.**† Even at these low prices, there's no scrimping on performance. You

have the bandwidth for digital and analog circuits. The sensitivity for low signal measurements. The sweep speeds for fast logic families. And delayed sweep for fast, accurate timing measurements. All scopes are UL Listed and CSA approved.

**You can order, or obtain literature, through the Tek National Marketing Center.** Technical personnel, expert in scope applications, will answer your questions and expedite delivery. Direct orders include comprehensive 3-year warranty\*, operator's

manual, two 10X probes, 15-day return policy and worldwide service backup.

**Order toll free:  
1-800-426-2200,  
Ask for Rick.**

In Oregon, call collect (503) 627-9000. Or write Tektronix, Inc. P.O. Box 500, Delivery Station Y6-088 Beaverton, OR 97077

**Tektronix**  
COMMITTED TO EXCELLENCE

## FEATURES

- 23 **Budget Robotics**—discover life-like gadgets you can own today  
40 **Updating the Experimenter's Shop**—today's budget test gear and hand tools will make your hobby fruitful  
54 **E.M.P.**—it will wipe out AC power, telephones, airplanes, radio!  
66 **Good News from a Telephone Keypad**  
73 **Digital Fundamentals**—The first in a series of short courses  
87 **Gate Drivers**—you can interface logic to power circuits

## PROJECTS YOU CAN BUILD

- 31 **Stereo Power Meter**—a dot/bar display driver is its heart  
44 **Picture Fixer**—inverts video and keeps the sync-pulses right-side up  
49 **Hands-Free Telephone**—keep on working while you listen and talk  
60 **Waveform Generator**—squarewave, sinewave and triangle wave from one chip  
62 **Jacob's Ladder**—a climbing electric arc that's fun to watch  
68 **Adding Direct Video to CoCo**—take the fuzz out of 80-character displays  
78 **Junkbox RF Modulator**—it can drive your color monitor  
81 **Phototach**—count the pulse of an interrupted light source

## MINI-PROJECTS

- 65 **Extension Phone Ringer**—It's inexpensive and easy to assemble  
71 **Toy Organ**—a full octave of fun  
72 **British Hee-Haw Siren**—add a Scotland Yard touch to your burglar-alarm system  
92 **Low-power Polarity Inverter**—get the other polarity from what you have now  
93 **Push-on/Push-off Electronic Switch**—more fun than a toggle

## SPECIAL COLUMNS

- 67 **Friedman on Computers**—lightweight printers that burn and squirt  
86 **Calling All Hams**—String your own inverted long-wire antenna  
90 **Jensen on DX'ing**—reaching out to log the nations of Asia  
91 **Saxon on Scanners**—all about repeaters for mobile units

## DEPARTMENTS

- 2 **Editorial**—Thank you for the letters  
6 **New Products Showcase**—gadgets and tools new on the market  
15 **Bookshelf**—titles for beginners and pros to consider  
21 **Letters**—We answer some of the questions you ask

### Thank you for the letters!

**Hands-on Electronics** is going through some changes. It doesn't take a keen eye to see how the editors of this magazine are striving to present to the readers the best possible issue that we can. This quest for excellence happens every issue. So far, the editors have had it relatively easier than other editors, because our readers have been sending us interesting letters specifying exactly what they would like to see in the magazine. Because of your expressed interest, stories appear in this issue on robotics, EMP, and test equipment.

The robotics article was enjoyable to prepare for publication, because it covered those products our readers could buy today and use immediately. Some are toys, but we are all going through a learning process in a new, vast subject area that will be the pace-setter for the remainder of the '80's; and any gadget that'll help us learn is valuable. Heath's Heros are excellent learning devices and are by far the most sophisticated learning devices we can bring into our homes and classrooms.

EMP, the buzz-word abbreviation for electromagnetic pulse, is now considered the most viable nuclear attack and countermeasure technique. In the article on that subject in this issue we tell our readers how an EMP is generated and the effect it will have on our lives. We are appalled at the possibility of nuclear blasts in the high atmosphere; nevertheless we should understand what the situation is, and how the nation can protect itself.

More readers talked about test equipment than any other subject in the last few months, so we decided to present an article on how the beginner can set up a workbench top complete with test gear that he would need for basic project building and troubleshooting. We tossed in a few tool ideas, too! The advantages of budget items are discussed, although we suspect that when a hobbyist replaces an existing digital multimeter he usually steps up to one in the next, or better, price range that provides additional features.

Enjoy this issue, because we have enjoyed preparing it for you. And, if you have any comments, we would be more than happy to receive them.



Julian S. Martin  
Editor

Cover photo by Walter Herstat  
Composition and interior design by  
Mates Graphics

## STAFF

**Hugo Gernsback** (1884-1967) founder  
**M. Harvey Gernsback**, editor-in-chief  
**Larry Steckler**, CET, publisher  
**Art Kleiman**, editorial director  
**Julian S. Martin**, KA2GUN  
editor

**Carl Laron**, associate editor  
**Brian C. Fenton**, associate editor  
**Ruby M. Yee**,  
production manager  
**Robert A. W. Lowndes**, production  
associate  
**Karen S. Tucker**, production assistant  
**Dianne Osias**, production assistant  
**Jacqueline P. Weaver**, circulation director  
**Arline R. Fishman**,  
advertising coordinator

### BUSINESS AND EDITORIAL OFFICES

Gernsback Publications, Inc.  
200 Park Ave. S., New York, NY 10003  
President: M. Harvey Gernsback  
Vice President: Larry Steckler



### NATIONAL ADVERTISING SALES

Joe Shere  
1507 Bonnie Doone Terrace  
Corona Del Mar, CA 92625  
714/760-8697

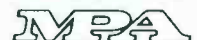

**Hands-on Electronics**, (ISSN 0743-2968) published quarterly by Gernsback Publications, Inc., 200 Park Avenue South, New York, NY 10003. Phone 212-777-6400. Four-issue subscription rate is \$10.00 — U.S. funds only. Canada subscribers add \$3.00 for postage. All others add \$7.00. Mail all subscription orders, address changes, correspondence and Postmaster Notices of undelivered copies (Form 3579) **Hands-on Electronics**, Subscription Dept., P.O. Box 338, Mount Morris, IL 61054. U.S. single-copy price \$2.50. © 1985 by Gernsback Publications, Inc. All rights reserved. Printed in U.S.A.

A stamped self-addressed envelope must accompany all submitted manuscripts and/or artwork or photographs if their return is desired should they be rejected. We disclaim any responsibility for the loss or damage of manuscripts and/or artwork or photographs while in our possession or otherwise.

As a service to readers, **Hands-on Electronics** publishes available plans or information relating to newsworthy products, techniques and scientific and technological developments. Because of possible variances in the quality and condition of materials and workmanship used by readers, **Hands-on Electronics** disclaims any responsibility for the safe and proper functioning of reader-built projects based upon or from plans or information published in this magazine.

# ELECTRONICS BOOK CLUB

The Best Source for Hobbyists and Professionals  
for Over 19 Years!

Time- and Money-Saving Advice . . .  
Practical Troubleshooting & Repair Tips . . .  
State-of-the-art Technology . . . Hundreds  
of Projects . . . Plus, Exceptional Savings

## Take Any 4 Books for Only \$2<sup>95</sup>

Values to  
~~\$85.00~~

Join Now, Get a Utility Apron FREE!



1492  
List \$14.95



1553  
List \$15.95



1277  
List \$21.95



1673  
List \$13.95



1409  
List \$15.95

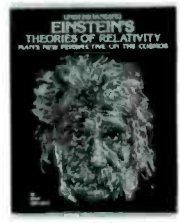

1505  
List \$11.50 (paper)

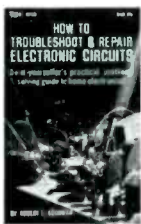

1218  
List \$18.95

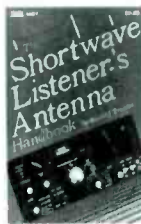

1487  
List \$15.95



1211  
List \$9.95 (paper)



1199  
List \$19.95



1539  
List \$21.95



1498  
List \$10.25 (paper)



1108  
List \$16.95



1465  
List \$16.95



1537  
List \$16.95

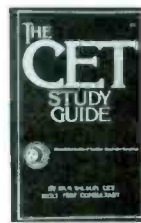

1791  
List \$16.95

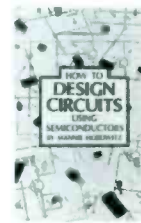

1543  
List \$19.95



1529  
List \$14.50 (paper)

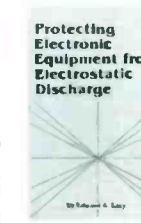

1820  
List \$16.95



1577  
List \$19.95



1183  
List \$16.95



1542  
List \$21.95



1699  
List \$19.95



1431  
List \$17.95



1474  
List \$16.95



800  
List \$19.50 (paper)

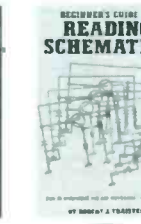

1536  
List \$14.95



1719  
List \$16.95

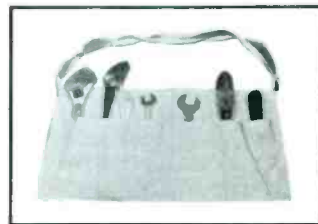

FREE Utility Apron

## 7 very good reasons to join the Electronics Book Club

- **Big Savings.** Save 20% to 75% on books sure to increase your electronics know-how
- **No-Risk Guarantee.** All books returnable within 10 days without obligation
- **Club News Bulletins.** All about current selections—main, alternates, extras—plus bonus offers. Comes 13 times a year with hundreds of up-to-the-minute titles to pick from
- **Automatic Order.** Do nothing and the Main selection will be shipped automatically! But . . . if you want an Alternate selection—or no books at all—we'll follow the instructions you give on the reply form provided with every News Bulletin
- **Bonus Books.** Immediately get a Dividend Certificate with every book purchased and qualify for big discounts of 60% to 80%
- **Extra Bonuses.** Take advantage of added-value promotions, plus special discounts
- **Exceptional Quality.** All books are first-rate publisher's editions selected by our Editorial Board and filled with useful up-to-the-minute information

## ELECTRONICS BOOK CLUB

P.O. Box 10  
Blue Ridge Summit, PA 17214

Please accept my membership in the Electronics Book Club and send the 4 volumes circled below, plus my FREE utility apron billing me \$2.95 plus shipping and handling charges. If not satisfied, I may return the books within ten days without obligation and have my membership canceled. I agree to purchase 4 or more books at reduced Club prices (plus shipping/handling) during the next 12 months, and may resign any time thereafter.

800 1108 1183 1199 1211 1218 1277 1409 1431  
1465 1474 1487 1492 1498 1505 1529 1536 1537 1539  
1542 1543 1553 1577 1673 1699 1719 1791 1820

Name \_\_\_\_\_ Phone \_\_\_\_\_

Address \_\_\_\_\_

City \_\_\_\_\_

State \_\_\_\_\_ Zip \_\_\_\_\_

Valid for new members only. Foreign applicants will receive special ordering instructions. Canada must remit in U.S. currency. This order subject to acceptance by the Electronics Book Club.

RESP-285





# SUPER LONG PLAY TAPE RECORDERS

10 Hour Model - \$95.00\*  
14 Hour Model - \$159.00\*

Modified Panasonic Slimline. high quality. AC-DC Recorders provide 5 or 7 continuous hours of quality recording & playback on each side of cassette for a total of 10 or 14 hours depending on model. Built-in features include • Voice level control • Digital counter, etc. TDK DC 180 Cassette Furnished.

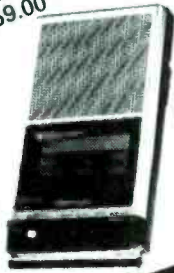

## PHONE RECORDING ADAPTER

Records calls automatically. All Solid state connects to your telephone jack and tape recorder. Starts recording when phone is lifted. Stops when you hang up.



\$24.50\*  
FCC APPROVED

## VOX VOICE ACTIVATED CONTROL SWITCH

Solid state. Self contained. Adjustable sensitivity. Voices or other sounds automatically activate and control recorder. Uses either recorder or remote mike.



\$24.95\*

\*Add for ship & hdg. Phone Adapter & Vox \$1.50 ea. Recorders \$4.00 ea. Cal. Res. add tax. Mail order, VISA, M/C, COD's OK. Money Back Guarantee. Qty disc. avail. Dealer Inquiries invited. Free data.

AMC SALES INC. Dept A 9335Lubec St., Box 928, Downey, CA 90421 (213) 869-8519

CIRCLE 905 ON FREE INFORMATION CARD

## MULTI-CHANNEL DUAL POLARITY

### MICROWAVE TV SYSTEMS

Complete Systems From \$69.95

Full 800 MHz Range  
Antenna Tunes 1.9 to 2.7 GHz  
Includes All ITFS Channels

DEALERS WANTED

COO's and Credit Card Orders Call TOLL FREE 1-800-247-1151

**GALAXY Electronics**  
5644 N. 53rd Avenue  
Glendale, AZ 85301

1-602-247-1151

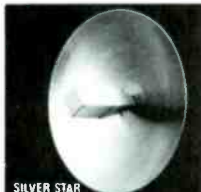

CIRCLE 910 ON FREE INFORMATION CARD

# NEW PRODUCTS SHOWCASE

## All Circuit Evaluators

A P PRODUCTS, originator of the modern solderless breadboard, has expanded its well-known line of All Circuit Evaluators to accommodate even larger testing and prototyping projects. New to the A P line are ACE 245 and ACE 254.

The ACE 245 features a universal matrix of 4488 solderless, plug-in tie-points and is composed of 640 separate 5-tie-point terminals, 40 vertical distribution buses, each with 5 connected 5-tie-point terminals, plus 4 horizontal buses, each with 18 connected 4-tie-point terminals. Busses can be used for power, ground, signal lines and more.

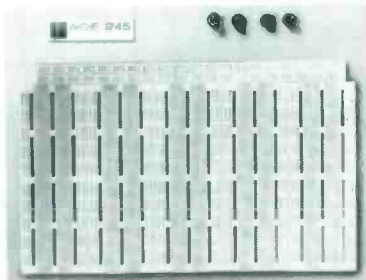

A P PRODUCTS ACE 245

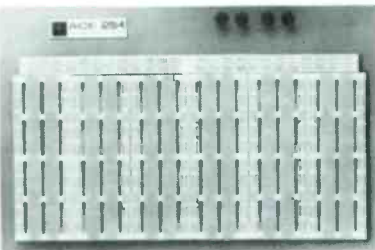

A P PRODUCTS ACE 254

CIRCLE 976 ON FREE INFORMATION CARD

For even larger projects, the ACE 254 combines the plug-in ease of a 0.1 in. x 0.1 in. solderless matrix with the convenience of 768 separate distribution buses of 5-tie-points each, plus 4 horizontal buses, each with 24 connected 4-tie-point terminals. Buses may be linked in various combinations to provide voltage and ground distribution reset lines, clock lines, shift commands and more. The matrix of 5424 solderless plug-in tie-points accepts DIP's of all sizes and a wide variety of discrete components with leads up to .032-inch in diameter. DIP capacity is up to 54 14-pin DIPS.

The ACE 245 and ACE 254 have termi-

nals of copper alloy 770 and the insulator is acetal copolymer. Circuit elements are easily interconnected with ordinary #22 AWG solid wire. The solderless breadboarding elements are permanently mounted to a metal base plate which functions as a ground plane. Connections to power supplies, signal generators or other external equipment are made via 4 standard 5-way binding posts attached to the base plate.

A P's full line of 10 All Circuit Evaluators are ideal for designing, testing and modifying circuits of all sizes. For more information, or the name of the nearest distributor, call toll free: 800/321-9668. In Ohio, call collect: 216/354-2101. You can write to A P Products, Inc. at 9450 Pineneedle Dr., Box 540, Mentor, OH 44060.

## Contact Cleaner

For fast, efficient cleaning of precision instruments and electrical/electronic components, consider LPS Electro Contact Cleaner. It is a premium-grade solvent specially formulated for cleaning electrical/electronic components, delicate mechanisms and precision instruments. It instantly removes dust, lint, airborne oils, carbon, and oxide particles, and other light contaminants, while leaving no harmful residue. LPS Electro Contact Cleaner is safe to use on rubber, paint, and plastic. It is non-conducting and



CIRCLE 960 ON FREE INFORMATION CARD

(Continued on page 8)



# Radio Shack Parts Place®

Famous for Value! The Store for Builders Since 1921

## 4000-Series CMOS ICs

With Pin-Out and Specs



Type	Cat. No.	Each
4001	276-2401	.99
4011	276-2411	.99
4013	276-2413	1.19
4017	276-2417	1.49
4049	276-2449	1.19
4066	276-2466	1.19

## TTL Digital ICs

With Pin-Out and Specs

Type	Cat. No.	Each
7400	276-1801	.89
7404	276-1802	.99
7408	276-1822	1.29
7447	276-1805	1.59
7490	276-1808	1.09

## Operational Amplifiers



Type	Cat. No.	Each
741 (Single)	276-007	.89
MC1458 (Dual)	276-038	.99
LM324 (Quad)	276-1711	1.29
TL082 (Dual)	276-1715	1.89
TL084 (Quad)	276-1714	2.99
LM3900 (Quad)	276-1713	1.39
LM339 (Quad)	276-1712	1.49
TLC271 (Single)	276-1748	1.59
TLC272 (Dual)	276-1749	2.19
TLC274 (Quad)	276-1750	2.99

## Power Transformers

120 VAC Primaries

Type	Volts	Current	Cat. No.	Each
PC Mini	12.0 CT	120 mA	273-1360	2.49
Miniature	6.3	300 mA	273-1384	2.59
Miniature	12.6	300 mA	273-1385	2.79
Miniature	25.2	300 mA	273-1386	3.49
Miniature	12.6 CT	450 mA	273-1365	3.59
Miniature	25.2 CT	450 mA	273-1366	3.99
Standard	6.3	1.2 A	273-1351	3.99
Standard	12.6 CT	1.2 A	273-1352	4.99
Standard	25.2	1.2 A	273-1353	5.99
Heavy-Duty	12.6 CT	3.0 A	273-1511	5.99
Heavy-Duty	25.2 CT	2.0 A	273-1512	6.29
Heavy-Duty	18.0 CT	2.0 A	273-1515	6.99

CT = Center Tap

## Ceramic Disc Capacitors

Low As **39¢** Pkg. of 2



Hi-Q. Moistureproof coating. 50 WVDC minimum.

pF	Cat. No.	Pkg. of 2	µF	Cat. No.	Pkg. of 2
4.7	272-120	39	001	272-126	39
47	272-121	39	005	272-130	39
100	272-123	39	01	272-131	39
220	272-124	39	05	272-134	49
470	272-125	39	1	272-135	49

## 1/4-Watt, 5% Resistors

Pkg. of 5 **39¢**

Ohms	Cat. No.	Ohms	Cat. No.
10	271-1301	10k	271-1335
100	271-1311	15k	271-1337
150	271-1312	22k	271-1339
220	271-1313	27k	271-1340
270	271-1314	33k	271-1341
330	271-1315	47k	271-1342
470	271-1317	68k	271-1345
1k	271-1321	100k	271-1347
1.8k	271-1324	220k	271-1350
2.2k	271-1325	470k	271-1354
3.3k	271-1328	1 meg	271-1356
4.7k	271-1330	10 meg	271-1365
6.8k	271-1333		

## Replacement Transistors



Type	Cat. No.	Each
2N1305	PNP	276-2007 1.19
MPS2222A	NPN	276-2009 .79
PN2484	NPN	276-2010 .89
MPS3904	NPN	276-2016 .69
TIP31	NPN	276-2017 .99
TIP3055	NPN	276-2020 1.59
MPS2907	PNP	276-2023 .79
MJE34	PNP	276-2027 1.49
2N3053	NPN	276-2030 .99
MPS3638	PNP	276-2032 .79
TIP120	NPN	276-2068 1.29
2N3055	NPN	276-2041 1.99
MJ2955	NPN	276-2043 2.19
2N4401	NPN	276-2058 .59
MPSA06	NPN	276-2059 .59
MPSA13	NPN	276-2060 .59
MPSA42	NPN	276-2061 .69
2SC945	NPN	276-2051 .79
2N3819	N-FET	276-2035 .99
MPF102	N-FET	276-2062 .99
IRF511	V-FET	276-2072 2.59
IRFD123	V-FET	276-2073 1.49
2SC1308	NPN	276-2055 7.95

## Power Supply Diodes

Micromini 1-Amp Diodes. 30 A surge.

Type	PIV	Cat. No.	Pkg. of 2
1N4001	50	276-1101	49
1N4003	200	276-1102	59
1N4004	400	276-1103	69
1N4005	600	276-1104	79

3-Amp "Barrel" Diodes. 200 A surge.

Type	PIV	Cat. No.	Pkg. of 2
1N5400	50	276-1141	79
1N5402	200	276-1143	89
1N5404	400	276-1144	99

## Voltage Regulators



Type	Adjustable	Cat. No.	Each
LM723	0 to 40 VDC	276-1740	.99
LM317T	1.2 to 37 VDC	276-1778	2.79

Type	Fixed Output	Cat. No.	Each
7805	+ 5 VDC	276-1770	1.59
7812	+ 12 VDC	276-1771	1.59
7815	+ 15 VDC	276-1772	1.59
7905	- 5 VDC	276-1773	1.59
7912	- 12 VDC	276-1774	1.59

## Mini 5 VDC Relays

Low As **1.99**



SPDT DIP Relay. Fits 14-pin DIP socket or mounts on PC boards.  $3/8 \times 9/16 \times 3/8$ ". Contacts: 2 amps at 125 VAC. 5 VDC, 70-ohm coil. **275-243 . . . 2.49**  
 Micro-Mini SPDT. Just  $11/32 \times 3/8 \times 1/4$ ". Contacts raged lamp at 125VAC. 5VDC, 55-ohm coil. .100" pin spacing. **275-240 . . . . . 1.99.**  
 DPDT DIP Relay. Fits 16-pin DIP socket or PC boards. Contacts: 1 amp at 125 VAC. Coil: 5VDC, 50 ohms.  $7/16 \times 25/32 \times 3/8$ ". **275-215 . . . . . 3.99**

## Getting Started in Electronics

**2.49**

By Forrest Mims III

Teaches basic electronics with an emphasis on ICs. Easy-to-read text and diagrams. 128 pages. Already a "classic." **276-5003 . . . . . 2.49**

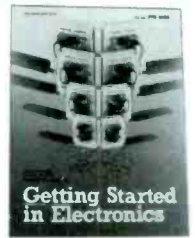

## Fold-Up Autoranging Multimeter



**79.95**

Advanced Technology That "Thinks"!

Automatic range-setting, polarity reverse, power-off. Big  $11/16$ " LCD display. "Beep" continuity. Diode/semi junction test. Pushbutton ohms zero adjust. With leads, manual. Batteries extra. **22-193 . . . . . 79.95**

## Digital Logic Probe

**19.95**



Simultaneous Tone Output Frees Eyes for Faster Testing

The fast way to "peek inside" TTL, LS and CMOS digital circuits. Color-coded LEDs indicate high, low or pulsed logic states. Switchable tone output. Overload and polarity protected. **22-302 . . . . . 19.95**

## Dynamic Transistor Checker

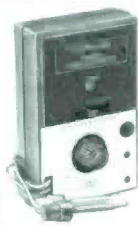

Only **14.95**

Tests In or Out of Circuit

LED indicates relative current gain, "opens" and "shorts." Socket plus hook-clip leads for in-circuit tests. Output jack for external meter or scope.  $2 3/4 \times 4 3/8 \times 1 3/16$ ". Requires "AA" battery. **22-025 . . . . . 14.95**

## Regulated DC Supply



Breaker Protected **34.95**

Converts 120 VAC to 12 VDC

Ideal test bench power source for autosound, CBs, ham rigs and more. Produces 13.8 VDC at 2.5 amps continuous load. 5 A surge. Rugged metal cabinet.  $2 1/2 \times 4 1/2 \times 6 3/4$ ". U.L. listed. **22-124 . . . . . 34.95**

Over 1000 items in stock: Binding Posts, Books, Breadboards, Buzzers, Capacitors, Chokes, Clips, Connectors, Fuses, Hardware, ICs, Jacks, Knobs, Lamps, Multitesters, PC Boards, Plugs, Rectifiers, Relays, Resistors, Switches, Tools, Transformers, Transistors, Wire, Zeners, and more!

**Radio Shack®**  
A DIVISION OF TANDY CORPORATION

Prices apply at participating Radio Shack stores and dealers

**TOLL FREE ORDERS • 1-800-826-5432**

(IN CALIFORNIA: 1-800-258-6666)

INFORMATION • (213) 380-8000

**L.E.D.'S  
STANDARD JUMBO  
DIFFUSED**

RED 10 FOR \$1.50  
GREEN 10 FOR \$2.00  
YELLOW 10 FOR \$2.00

**FLASHER LED  
5 VOLT OPERATION  
RED JUMBO SIZE  
\$1.00 EACH**

**BIPOLAR LED  
2 FOR \$1.70  
SUB MINI LED**

079 • 098  
RED 10 FOR \$1.00  
200 FOR \$18.00  
GREEN 10 FOR \$1.50

**EDGE  
CONNECTORS**

22/44 22/44 GOLD PLATED CONTACTS

156 CONTACT SPACING  
\$2.00 EACH 10 FOR \$18.00

28/56 28 56 GOLD PLATED CONTACTS  
156 CONTACT SPACING

\$2.50 EACH 10 FOR \$22.00

50/100 MICRO PLASTIC  
AMP 0125 50 DS 1  
STANDARD S 100 CONNECTOR  
125 SPACING GOLD PLATED  
PC MOUNT

\$3.75 EACH 10 FOR \$35.00

**13 VDC RELAY**

CONTACT S P N C  
10 AMP @ 120 VAC  
ENERGIZE COIL TO  
OPEN CONTACT  
COIL 13 VDC 650 OHMS  
SPECIAL PRICE \$1.00 EACH

**KEY ASSEMBLY  
5 KEY**

\$1.00 EACH  
CONTAINS 5 SINGLE-POLE  
NORMALLY OPEN SWITCHES  
MEASURES 3 3/4" LONG

**6 KEY**

\$1.25 EACH  
CONTAINS 6 SINGLE-POLE  
NORMALLY OPEN SWITCHES  
MEASURES 4 1/4" LONG

**SUB-MINIATURE  
D TYPE  
CONNECTOR**

SOLDER TYPE SUB MIN ATURE  
CONNECTORS USED IN  
COMPUTER-HOOK UPS

DB 15 PLUG \$2.75  
DB 15 SOCKET \$4.00  
DB 15 HOOD \$1.50  
DB 25 PLUG \$2.75  
DB 25 SOCKET \$3.50  
DB 25 HOOD \$1.25

**MULTI-SWITCHES**

**5 STATION INTERLOCKING**  
3 2PDT AND 2 6PDT SWITCHES ON FULLY  
INTERLOCKING ASSEMBLY 3" BETWEEN  
MOUNTING CENTERS \$2.50 EACH

**5 STATION NON-INTERLOCKING**  
SAME AS ABOVE EXCEPT EACH SWITCH  
OPERATES INDEPENDENTLY \$2.50 EACH

SEND FOR NEW LARGER 48 PAGE CATALOG

**COMPUTER  
GRADE  
CAPACITORS**

2,000 mfd. 200 VDC \$2.00  
1 3/4 DIA 5 HIGH

3,600 mfd. 40VDC \$1.00  
1 3/8 DIA 3" HIGH

6,400 mfd. 60 VDC \$2.50  
1 3/8 DIA 4 1/4 HIGH

22,000 mfd. 15 VDC \$2.00  
2 DIA 2 1/2 HIGH

22,000 mfd. 40 VDC \$2.00  
2 DIA 6 HIGH

24,000 mfd. 30 VDC \$3.50  
1 3/4 DIA 8 HIGH

31,000 mfd. 15 VDC \$2.50  
1 3/4 DIA 8 HIGH

72,000 mfd. 15 VDC \$3.50  
2 DIA 4 HIGH

180,000 mfd. at 6V \$1.50  
2 1/2" DIA 4 1/2" HIGH

CLAMPS TO FIT CAPACITORS 50¢ EA

**SOLDERING  
IRON STAND**

SPRING STEEL  
IRON HOLDER

ON WEIGHTED BASE  
\$5.00 EACH

**WALL  
TRANSFORMER**

ALL ARE 115 VAC  
PLUG IN

4 VDC at 70 MA \$2.50  
9 VDC at 225 MA \$3.00  
16.5 VAC at 10 VA \$3.50  
17 VAC at 500 MA \$4.00

**MINIATURE TOGGLE SWITCHES**  
ALL ARE RATED 5 AMPS @ 125 VAC

**S.P.D.T.  
(on-on)**  
PC STYLE  
NON THREADED  
BUSHING  
75¢ EACH  
10 FOR \$7.00

**S.P.D.T.  
(on-on)**  
SOLDER LUG  
TERMINALS  
\$1.00 EACH  
10 FOR \$9.00  
100 FOR \$80

**S.P.D.T.  
(on-off-on)**  
SOLDER LUG  
TERMINALS  
\$1.00 EACH  
10 FOR \$9.00  
100 FOR \$80.00

**S.P.D.T.  
(on-off-on)**  
NON THREADED  
BUSHING  
PC STYLE  
75¢ EACH  
10 FOR \$7.00

**S.P.D.T.  
(on-on)**  
PC LUGS  
THREADED  
BUSHING  
\$1.00 EACH  
10 FOR \$9.00  
100 FOR \$80.00

**D.P.D.T.  
(on-on)**  
SOLDER LUG  
TERMINALS  
\$2.00 EACH  
10 FOR \$19.00  
100 FOR \$180.00

**NEW PRODUCTS**

(Continued from page 6)

won't attract dust or generate static electricity, making it especially effective on circuit boards and electronic components. It is also ideal for thermal testing of circuits, thermostats and PC boards. For more information, contact Holt Lloyd Corporation, 4647 Hugh Howell Road, Tucker, GA 30084, or telephone 800/241-8334.

**FILE A DISK SYSTEM**

A new state-of-the-art computer 5-1/4-in. floppy disk storage system has been developed and called Pic-A-Disk. The system is a major improvement in disk storage. The unique design and color-coding features make instant disk location and identification a reality. PIC-A-DISK also serves as a filing system, an organizer, and a problem solver. It is now virtually impossible to misfile or lose a disk. PIC-A-DISK holds 50 disks in an attractive desk top storage tray. Its flip lid and positive catch features prevent



CIRCLE 948 ON FREE INFORMATION CARD

moisture and dust from penetrating the unit when sealed. It carries a retail price of \$29.95. For further information, or to place an order, write to: M & R Distributing Co., Inc., 2901 Long Beach Road, P.O. Box 190, Oceanside, NY 11572

**YOUR CAR CALLING**

Wolo's personal paging system is a total security package. Car Call, Model 4500 uses 4-watts of transmitted RF power, broadcasting through an existing vehicle antenna. A personal-carried receiver beeps and flashes a LED light upon unauthorized intrusion into the car. A feature of the 4500—it will activate an existing audible alarm or the vehicle's horns when its easy-one-wire circuit is used. Through hi-tech solid-state circuits, Car Call has built-in turn off and reset timing.



CIRCLE 975 ON FREE INFORMATION CARD

Its current monitor makes the 4500 one of the fastest installing systems of its kind in the industry. The molded cases of both receiver and transmitter are made of high-impact plastic. Quality electronic components are used throughout assuring years of dependable service. That model of Car Call sells for \$119.99. For more information, contact Wolo Manufacturing Corp., One Saxwood Street, Deer Park, New York 11729.

**WORDSTAR AND FRIENDS**

The popular WordStar word-processing program and the WordStar Professional Options package are now available for use on the Tandy TRS-80 Model 2000 computer.

WordStar (90-0105; \$495.00) is a full-feature word-processing program with extensive self-help menus available on-screen. Its capabilities include formatting, block insertions and deletions, headers and footers, global word search, and justification of right margin. Printing options include boldface, underline, double strike, overprint, superscript and subscript.

The WordStar Professional Options package is a composite of utility programs to complement the WordStar word-processing program. WordStar Professional Options (90-0111; \$345.00) includes the MailMerge, CorrectStar, and StarIndex programs.

MailMerge (90-0106; \$250.00) is a powerful merging utility for creating form letters that appear to be written individually, inserting standard paragraphs into individual letters or documents, and printing multiple files into one continuous document. MailMerge includes a sophisticated nested printing capability that will stop printing one document, print the nested file, then return to the original document. With MailMerge, a file can be nested inside another file which is itself nested, etc., up to seven levels.

CorrectStar (90-0108; \$195.00), designed to be both fast and comprehensive, checks words in a WordStar file against three dictionaries—a fast dictionary in RAM containing 9,000 words, a big dictionary on disk with 65,000 words, and a personal dictionary of up to 1,500 words.

(Continued on page 10)

HANDS-ON ELECTRONICS

**ALL ELECTRONICS CORP.**

905 S. VERMONT • P.O. BOX 20408 • LOS ANGELES, CA 90008

- QUANTITIES LIMITED
- FOREIGN ORDERS
- MINIMUM ORDER \$18.00
- INCLUDE SUFFICIENT SHIPPING
- USA: \$2.50 SHIPPING
- CALIF. RES. ADD 8 1/2%
- NO C.O.D.

From the Publishers of Radio-Electronics

**Hands-on Electronics**

THE MAGAZINE FOR THE ELECTRONICS ACTIVIST!

\$2.50 U.S. FALL 1984  
\$2.95 CANADA

48784  
# 2  
FALL 1984

**DIGITAL TACHOMETER for Your Car**

**POCKET SAFETY FLARE Slows Traffic**

**650-MHz AMP-PRESCALER PROBE**

**AUTOMATIC DARKROOM TIMER**

**CAPACITANCE METER**

**Build a 1920-Style Wireless Receiver**



- How your ears react to sounds!
- Voltage regulator design tips!
- Analog Anemometer measures the wind!

**LOOK FOR OUR NEW NAME!**

# HANDS-ON ELECTRONICS

**FORMERLY SPECIAL PROJECTS**

**Get every issue!**

**SUBSCRIBE TODAY!**

**Use the order form below.**

## Subscribe Today!

■ IF YOU'RE THE KIND OF READER that doesn't want to wait, you can order your next copy of **Hands-on Electronics** now. **Hands-on Electronics** is crammed full of electronic projects that you won't be able to wait to build for yourself. You can expect top-notch digital projects, fun-to-play electronic games, valuable add-on computer projects, BCB and shortwave receivers, photographic/darkroom gadgets, devices to improve your car's performance, test equipment ideas, and more in every issue of **Hands-on Electronics**.

■ TO HELP YOU TO BE SURE that you don't miss any future issues of **Hands-on Electronics**—SUBSCRIPTIONS ARE NOW AVAILABLE!

■ YOU CAN HAVE THE NEXT FOUR ISSUES of **Hands-on Electronics** delivered directly to your home for only \$10.00. We pay the postage. If you want the next eight issues, you can even save a dollar off the newsstand price. Get eight issues for \$19.00

■ EVERY ISSUE OF **Hands-on Elec-**

**tronics** will continue to contain a variety of construction articles to suit every taste. In addition, feature articles on electronics fundamentals, test equipment and tools will round out each issue. Of course, **Hands-on Electronics** will continue to provide new product and literature listings to keep you up to date on the latest developments in electronic technology.

■ GET IN ON THE ACTION! Order your next issue of **Hands-on Electronics** today. Use the convenient order coupon below. Be sure to send check or money order—no cash!

<p><b>Hands-on Electronics SUBSCRIPTION</b></p> <p><input type="checkbox"/> I want to be sure I don't miss any issues. Send me the next four issues of <b>Hands-on Electronics</b> for \$10.00 starting with #2. Postage is free in U.S. For Canada add \$2.00. Foreign add \$7.00</p> <p><input type="checkbox"/> I want to be sure I don't miss any issues and want to save \$1.00 too. Send me the next eight issues of <b>Hands-on Electronics</b> for \$19.00: starting with #2. Postage is free in U.S. For Canada add \$4.00. Foreign add \$14.00.</p> <p><input type="checkbox"/> Send me _____ copies of <b>Hands-on Electronics</b> #2 at \$2.50 plus \$1.00 postage and handling for U.S., Canada and Mexico \$1.00 per copy. U.S. funds only.</p>	<p>Detach and mail today to: HANDS-ON ELECTRONICS SUBSCRIPTION DEPT. P.O. BOX 338 MOUNT MORRIS, IL 61054</p>	<p>Allow 6-8 weeks for the first issue to arrive.</p>	<p>HOE # 3</p>
	<p>Please print</p> <p>_____ (Name)</p> <p>_____ (Street Address)</p> <p>_____ (City) (State) (Zip)</p>		

## NEW PRODUCTS

(Continued from page 8)

CorrectStar identifies the doubtful words and, using phonetic analysis, suggests a correction. The user can elect to accept the correction, ask for another suggestion, add the word to a personal dictionary, enter a correction from the keyboard, or continue without changing the spelling.

StarIndex (90-0109; \$195.00) lets the user create indexes, tables of contents, lists of figures, and lists of tables automat-

ically. As the WordStar document is created, words or phrases to be used in constructing the table of contents, indexes, or lists are identified by the user with special codes. Because the data for the indexes is extracted directly from the document, both accuracy and consistency are assured.

The WordStar auxiliary program (90-0107; \$150.00) checks words in a WordStar file against a 20,000 word dictionary. As SpellStar displays potentially misspelled words, the user can correct the spelling of the word, leave it as is, or add it

to a user-defined dictionary.

The individual WordStar programs and the WordStar Professional Options package are available through Radio Shack's Express Order Software program at Radio Shack Computer Centers, Radio Shack Stores, and participating Dealers.

## ELECTRONICS TOOL KIT

Jensen's JTK-16 zipper-pouch kit is designed for the electronics technician or field engineer requiring a complete set of tools in a compact package. The basic price is \$135.00, other models with added features are available at slightly higher prices. It contains more than 50 tools for use on computer and electronics equipment. Included are: 4 pair pliers, alignment tools, nutdrivers, screwdrivers, hex and spline wrench sets, adjustable



CIRCLE 968 ON FREE INFORMATION CARD

wrench, knife, file, wire stripper, soldering equipment and more.

The tools are furnished in an attractive padded zipper case. A Triplett model 310 VOM Meter is an optional accessory. For more information and free catalog describing more than 40 other electronics tool kits, write: Jensen Tools, Inc., 7815 S. 46th Street, Phoenix, AZ 85040. Telephone: 602/968-6231.

## NIBBLER CUTTING TOOL

Vaco's new Nibbler Cutting Tool No. 70376 is a unique device in that it provides a fast and easy method of cutting sheet metal or plastic. It can cut any shape of any size from either an external or internal starting point. The latter is done by starting with a 7/16-in. drilled hole.

That handy tool will quickly cut a hole, notch an edge, or trim a piece of material down to any desired size and shape with-

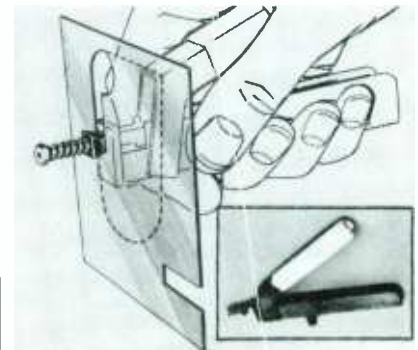

CIRCLE 939 ON FREE INFORMATION CARD

# A QUALITY TRIPLE-REGULATED POWER SUPPLY AT A LOW, LOW PRICE!!

NOT A KIT!

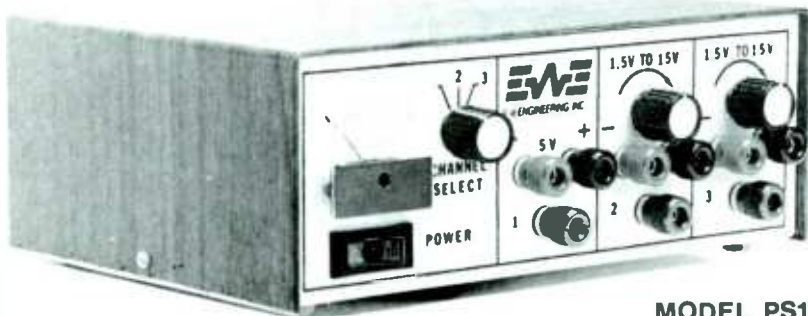

MODEL PS101  
FULLY ASSEMBLED & TESTED!

**\$ 119.88**  
FULL 1 YEAR REPLACEMENT WARRANTY  
- Made In The United States -

This DC triple regulated variable power supply has all the features you could ask for plus a full 1 year guarantee. Fully adjustable from 1½ VDC to 35 VDC! Three completely independent supplies that offer many advantages! They can be either a pos. supply or a neg. supply...they can also be stacked in series so that a 5V and two 15V supplies can total a 35 VDC supply or any combination of the three...(after one of the terminals is grounded to give it a reference)...for the first time you can now purchase this American made fully adjustable power supply at a price that is one-half of what you'd expect to pay!

### SPECIFICATIONS

3 outputs:  
Fixed 5 VDC ± 0.2V  
2 variable ≤ 1½ V to ≥ 15 VDC  
Polarity - floating; can be used as pos. or neg.  
Ripple less than 10mV at full load,  
Regulation ≤ 1% no load to full load,  
Line Regulation < 0.2% 108 VAC to 135 VAC.  
Current:  
Fixed supply 1.0 amp max.  
Variable supplies 0.5 amp max.

Protection built in, current limiting, with thermal shutdown.  
Power: 108-135 VAC.  
Dimensions: 8¼" x 3¾" x 7¼" (WxHxD)  
Wood grain finished metal case.  
Weight: 4 lbs., 9 ozs.  
Lighted on/off power switch, easy-to-read Voltmeter and large binding posts.  
Warranty: one year full replacement warranty from date of purchase.

DISTRIBUTOR AND REPRESENTATIVE INQUIRIES INVITED



VISA, MASTERCARD, AMEX TELEPHONE ORDERS ACCEPTED!  
6 Herman Drive, E. Granby, CT 06026 □ 203/651-0285

CIRCLE 920 ON FREE INFORMATION CARD

## NEW PRODUCTS

out distortion. It can follow sharp angles and tight curves, making it easy to use in tight quarters. The Nibbler will cut steel up to 18 gauge, copper, aluminum, and plastic up to 1/16 in., and tubing with a 1-in. inside diameter.

That tool is ideal for model making, home improvements such as gutter and aluminum siding work, electronic and engineering fabrication, plus many other applications. The new Nibbler Cutting Tool will be distributed in the U.S., Canada, and worldwide. For more information, write or call: Vaco Products Company, 1510 Skokie Blvd., Northbrook, IL 60062. Telephone.: 312/564-3300.

### JACK-OF-ALL-PLUGS

Mouser Electronics announces an expanded line of high-quality in-line, RCA jacks and plugs. The ME161-4200 series jacks and ME171-4200 series plugs are precision manufactured to provide firm, positive contact even when subjected to



CIRCLE 974 ON FREE INFORMATION CARD

continuous use. They feature gold-plated contacts and aluminum bodies with a gold, clear, or black anodized finish. The connectors are designed to accept RG-59 cable and are ideal for video and RF applications. Those quality RCA jacks and plugs are priced as low as \$3.95. Write or call for free catalog and prices. Contact Mouser Electronics, 11435 Woodside Avenue, Santee, CA 92071. Telephone 619/449-2222.

### Audio Signal Generator

Leader Instruments Corporation has introduced a new low distortion audio signal generator, the LAG-126S. The audio generator features balanced and unbalanced 600-ohm outputs and an extremely low-distortion rate which make the LAG-126S

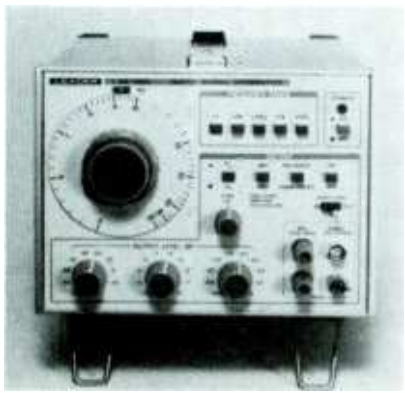

CIRCLE 945 ON FREE INFORMATION CARD

an ideal signal source for designing, testing, and servicing studio and consumer audio equipment.

The LAG 126S has 5 frequency ranges covering 5 Hz to 500 kHz with output voltage calibrated in dBm or dBv. The output attenuator range is -69.9 to +10 dB in 0.1 dB increments with fine adjust for precision control of level. A front panel on-off output voltage switch is convenient for making signal to noise measurements. For balanced outputs, the sine wave distortion is less than 0.005%

through 20 kHz. Also, squarewave outputs can be produced with a rise time of less than 200 ns, making the LLAG-126S a perfect low-frequency laboratory signal generator.

For further information on the LAG-126S and Leader's full line of test and measurement instruments including oscilloscopes, frequency counters, power supplies, meters and bridges, and video test equipment, contact Leader Instruments Corporation, 380 Oser Avenue,

(Continued on page 12)

## VIEW 8 TRACES ON YOUR SINGLE OR DUAL TRACE SCOPE WITH THIS LOW COST DEVICE!!



Now you no longer have to spend thousands on an expensive multi-trace oscilloscope - our single trace Hitachi scope combined with this module will allow you to view up to 8 simultaneously occurring analog or digital (or both) signals in their real time and amplitude relationship. The MPX 101 may be used on any oscilloscope, whether single, dual or multiple traces. Its low cost makes it a particular favorite for designers, testers, hobbyists and repairmen who want to compare and analyze displayed signals in a timing diagram format. The controls on the front panel of the metal case allow you to vary amplitude and spacing of the displayed signals.

MODEL MPX101  
FULLY ASSEMBLED & TESTED!



NOT  
A  
KIT

**\$ 99<sup>88</sup>**  
FULL 1  
YEAR  
REPLACE-  
MENT  
WARRANTY

- Made In The United States -

### SPECIFICATIONS

Inputs: 8 signals plus ground via 9 input leads terminated with alligator clips  
Bandwidth:  $\pm 1$  dB to 5 MHz  
Impedance: 10.9 K  
Input Voltage:  $\pm 5$  V peak (diode clamped to  $\pm 5$  Volt supplies)  
Output: Staircase waveform summed with input signals, 0-800 mV full scale  
Step Amplitude: Variable 0 to 150 mV/step  
Signal Voltage: Variable 0 to

150 mV/step @ 5V Input  
Multiplex Rate: Switch selectable, 40 KHz or 4 KHz  
Impedance: 50 Ohms  
Power: 105-135 VAC @ 1 V a  
Dimensions: 6.25" x 3.25" x 4.75" (WxHxD)  
Operating Temperature: 0-40°C  
Weight: 1 lb. 10.5 oz.  
Warranty: one year full replacement warranty from date of purchase  
Lighted on/off power switch  
Wood grain finished metal case

DISTRIBUTOR AND REPRESENTATIVE INQUIRIES INVITED



VISA, MASTERCARD, AMEX TELEPHONE ORDERS ACCEPTED!  
6 Herman Drive, E. Granby, CT 06026 □ 203/651-0285

CIRCLE 921 ON FREE INFORMATION CARD

# ELECTRONIC COMPONENTS

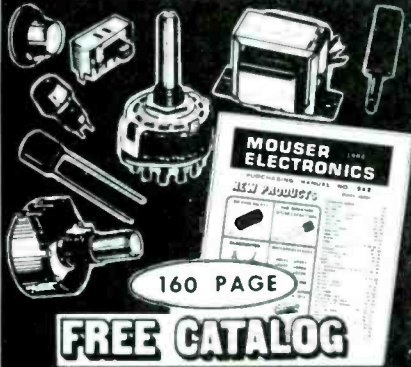

## MANUFACTURERS OF QUALITY ELECTRONIC COMPONENTS

- BATTERY CLIPS & HOLDERS
- CABLE SETS • CONNECTORS • CAPACITORS
- DISPLAYS • LEDs • FUSES • JACKS & PLUGS
- KNOBS • LAMPS • POTENTIOMETERS
- RF COILS • RELAYS • RESISTORS
- SWITCHES • SEMICONDUCTORS • SPEAKERS
- TEST EQUIPMENT • TRANSFORMERS • TOOLS
- WIRE & CABLE

OVER 15,000 DIFFERENT ITEMS IN STOCK!

- Sales and Order Desk Open from 6:00a.m. (PST)
- TERMS: C.O.D. Visa, MasterCard (Open Accounts Available)
- Phone and Mail Orders Welcome
- Catalogs Mailed Outside USA Send \$2.00

## MOUSER ELECTRONICS

11433 WOODSIDE AVE. SANTEE, CA 92071  
PHONE (619) 449-2222 TWX 910-331-1175

CIRCLE 906 ON FREE INFORMATION CARD

# Be an FCC LICENSED ELECTRONIC TECHNICIAN!

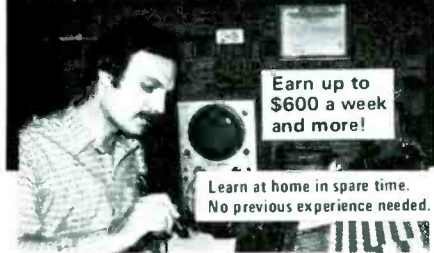

No costly School. No commuting to class. The Original Home-Study course that prepares you for the FCC Radiotelephone license exam in your spare time! An FCC Government license is your "ticket" to thousands of exciting jobs in Communications, Radio & TV, Mobile two-way, Microwave, Computers, Radar, Aerospace and more. You don't need a college degree to qualify, but you do need an FCC License. **No need to quit your job or go to school!** You learn how to pass the FCC License exam at home at your own pace with this easy-to-understand, proven course. It's easy, fast and low cost! **GUARANTEED PASS** You get your FCC License or money refunded. Write for free details. Soon you could be on your way to being one of the highest workers in the electronics field. **Send for FREE facts now. MAIL COUPON TODAY!**

## COMMAND PRODUCTIONS

FCC LICENSE TRAINING, Dept. 90  
P.O. Box 2223, San Francisco, CA 94126

Rush FREE facts on how I can get my FCC License in spare time. No obligation. No salesman will call.

NAME \_\_\_\_\_

ADDRESS \_\_\_\_\_

CITY \_\_\_\_\_

STATE \_\_\_\_\_ ZIP \_\_\_\_\_

## NEW PRODUCTS

(Continued from page 11)

Hauppauge, NY 11788. Tel.: 516/231-6900 or 800/645-5104 toll free.

### Audio Transformers

Mouser Electronics has a line of audio transformers designed for demanding PCB applications. Those transformers are fully shielded to reduce magnetic and electrostatic fields. The transformer body

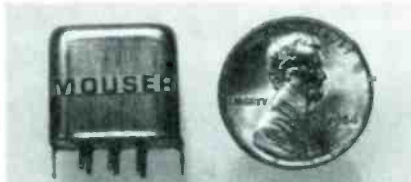

CIRCLE 974 ON FREE INFORMATION CARD

is entirely encapsulated in epoxy. That permits operation at high temperatures and keeps the PCB mounting pins securely attached to the transformer bobbin. Encapsulation also makes for stable mounting with plug-in ease. They are ideal for pulse and audio applications.

The transformers are only .65-in. square and .6-in. high. Lead spacing is .16 in. They are E1-14 core type and output a maximum .075 watts. Resistance ranges from 35 to 550 ohms primary winding, 1 to 500 ohms secondary winding. Stock impedances range from 500-CT to 10K-CT primary winding, 8-CT to 10K-CT secondary winding. Custom impedances are available.

Write for catalog and quantity prices: Mouser Electronics, 11433 Woodside Avenue, Santee, CA 923071. Tel.: 619/449-2222.

### Tandy 1200 HD PC

The newest MS-DOS operating system based computer in the Radio Shack line, the Tandy 1200 HD Personal Computer, offers IBM/XT capabilities at a savings of



CIRCLE 957 ON FREE INFORMATION CARD

up to \$1400 per system. The 1200 HD includes a 10-MB hard disk, and is functionally identical to the PC/XT, using the same software and option cards. At \$2,999, the Tandy 1200 HD computer represents a significant price/performance improvement. Where price and manufacturer support are important factors, and IBM compatibility is required, the Tandy 1200 HD computer is an alternative to the PC/XT.

The Tandy 1200 HD computer (Cat. No. 25-3000, \$2999) comes standard with 256K RAM, expandable to a total of 640K. A standard parallel interface—an extra-priced option on the IBM PC/XT—is included. And, the five expansion slots will accept option boards made for the IBM PC by a variety of leading vendors. In the standard configuration, one slot is used for the hard-disk controller and one slot is used for the floppy-disk controller.

Standard features of the Tandy 1200 HD computer parallel those of the IBM PC/XT computer by providing a single 360K full-height, double-sided, double-density, 5-1/4-in. floppy-disk drive and a 10-MB hard-disk drive housed in the desktop unit. The 84-key detachable keyboard with tilt legs has the same layout as the PC/XT, with improved placement of the shift keys.

The Tandy 1200 HD introductory user's guide takes you through setup and initial use. MS-DOS operating system version 2.11 plus Microsoft BASIC, along with user's manuals for each, are available for \$89.95 (Cat. No. 25-3130).

### Two-Outlet Surge Suppressor

Perma Power Electronics' new Surge Suppressor models, each featuring plug-

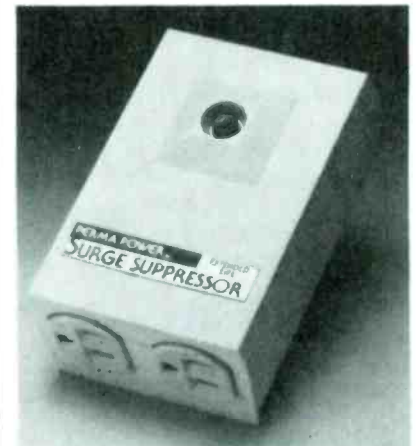

CIRCLE 959 ON FREE INFORMATION CARD

in capabilities, protect two pieces of equipment, such as a personal computer and a printer. Perma Power Surge Suppressors guard sensitive electronic equipment from damage caused by electrical power-line voltage transients.

(Continued on page 14)

This will be coming to you when you subscribe to **Radio-Electronics**

• **HELPFUL CONSTRUCTION ARTICLES...**

Test Equipment  
Hi-Fi Accessories  
Telephone Accessories  
Music Synthesizers  
Computer Equipment  
Automotive Equipment  
Intruder Alarms-  
Home & Car  
Video Accessories

• **NEWS ON NEW TECHNOLOGY**

Computers  
Microprocessors  
Satellite TV  
Teletext  
Automotive Electronics  
Speech Synthesizers  
IC Applications

• **FASCINATING "HOW TO DO IT" ARTICLES...**

Build Your Own Projects  
Make Your Own PC Boards  
Wiring Techniques  
Soldering and Desoldering  
Design and Prototyping



• **HOW YOU AND THE COMPUTER CAN BE FRIENDS...**

Getting Started  
Programs, Circuit  
Design, Games  
A/D-D/A Interfacing  
Peripheral Equipment

• **NEW AUDIO DIMENSIONS FOR YOUR PLEASURE...**

Noise-Reduction Devices  
How to Connect that  
Extra Add-On  
Hi-Fi Accessories  
New Technology

• **TV WONDERS FOR YOUR FUTURE...**

Latest Receivers and  
Circuits  
The Home Entertainment  
Center  
Projection TV  
Satellite TV Receivers  
Jack Darr's Monthly  
Service Clinic  
Service Problems and  
Solutions

• **REGULAR MONTHLY FEATURES**

DESIGNERS NOTEBOOK  
by Robert Grossblatt  
HOBBY CORNER  
by "Doc" Savage, K4SDS  
STATE-OF-SOLID-STATE  
by Bob Scott  
WHAT'S NEWS, new  
products, stereo news  
VIDEOGAMES, new  
products, game reviews  
and NEW IDEAS, STEREO  
PRODUCTS, NEW  
COMPUTER PRODUCTS  
FOR HOME/JOB and  
MUCH MORE!

Radio-Electronics covers all aspects of the fast moving electronics field...featuring  
**COMPUTERS • VIDEO • STEREO  
TECHNOLOGY • SERVICE  
COMMUNICATIONS • PROJECTS**

# Get it all!

Subscribe today to Radio-Electronics! Don't miss a single issue and...see subscription card in back of this issue for big savings.

When you select one of the subscription offers listed on the handy coupon—you'll be assured of having your copy reserved, even if it sells out on the newsstand. Make sure you get all the excitement in every issue of Radio-Electronics, every month, by filling in and mailing your subscription card today.



# LEARN COMPUTER REPAIR

**Train at home in spare time...  
No previous experience needed**

Sales of small computers are running over a billion dollars a year. That's why a whole new business is starting up—devoted entirely to small computer repair. And right now is the time to get in on the ground floor—either working for someone else or in your own computer repair business.

## Start making money in electronics

No need to quit your job, change your daily routine or take time from family responsibilities. And you don't waste time going to and from class because you train at home in spare time. The ICS Microcomputer Repair Course is designed for beginners—people with no previous experience who want to get started fast. And you should be ready for an entry-level job repairing small computers even before you finish this course.



You receive microprocessor trainer, digital V.O.M. and much more included with course.

**Experts show you what to do... how to do it!** We start you fast with the basics, and everything is explained in easy-to-understand language complete with plenty of diagrams and drawings

**GET INTO  
SMALL  
COMPUTER  
REPAIR**

**SEND FOR FREE FACTS!**

**ICS** School of Computer Repair, Dept. WMO25  
SINCE 1981 Scranton, Pennsylvania 18515  
Send free facts and color brochure telling how I can get into computer repair at home in my spare time. No obligation. No salesman will call.

Name \_\_\_\_\_ Age \_\_\_\_\_  
Address \_\_\_\_\_  
City/State/Zip \_\_\_\_\_

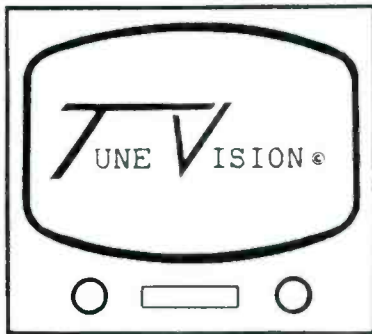

## A Color Pattern Generator on Video Tape

Do you want perfect picture quality on your TV? Are you a hobbyist? Do you repair your own TV? TuneVision is the answer. No need to purchase expensive electronic color pattern generator. Our product allows you to align or trouble shoot your TV, using your VCR. Pays for itself in just one use! Includes color bars, dots and cross-hatch patterns to align to manufacturer's specs. To order send \$19.95 plus \$2.25 for postage and handling to:

**BR&D ENTERPRISES INC.**  
P.O. Box 7575  
Dept. 209  
Newark, DE 19714-7575

CIRCLE 917 ON FREE INFORMATION CARD

## NEW PRODUCTS

(Continued from page 12)

Power protection covers both kinds of voltage surges: the *normal mode* surges most often caused by other equipment on the same power line being switched on and off; and the *common mode* surges most frequently caused by lightning.

The Model PT209 (\$33.00) offers single-stage suppression of power-line transients, whether normal mode or common mode. It uses three metal oxide varistors, providing protection on all three conductors in a typical 120-VAC circuit. The second Extended Life unit, Model PS209 (61.80) offers two-stage filtering, with a unique complementary circuit of both metal oxide varistors and silicon avalanche diodes.

## PC Repair Kit

Printed-circuit changes with tack-soldered wire loops and dangling components are gone forever with Circuit-Fix repair kit that includes adhesive copper donuts, foil, knife, and a combination clamp and cutting guide.

The clamp-guide makes cutting conductor traces as thin as 0.012-in. a simple

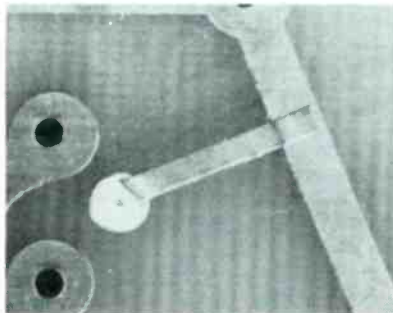
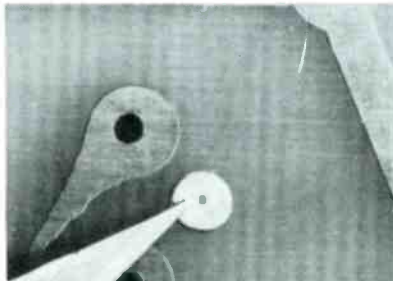

CIRCLE 967 ON FREE INFORMATION CARD

chore. The tool is opened with one hand while adhesive copper foil is slipped in place. The width is adjusted by hand while checking with a machinist's scale. The clamp-guide securely holds the foil, gives a true straight edge and keeps the blade perfectly vertical during the cut. Those conditions ensure perfect narrow traces. Repairs are made by pressing the trace onto the PC board, cutting off the excess with a knife and adding donuts (terminal pads) where required. Soldering insures electrical continuity.

The CF-1 Circuit-Fix is available for \$21.95 each. The CF-2 308 (assorted donuts) and the CF-3 (two sheets of copper foil) cost \$4.00 each. For more information, write to Datak Corporation, 65 71st Street, Guttenberg, NJ 07093.

## D-Subminiature Wall Plates

Mouser Electronics announces the availability of wall plates for D-subminiature connectors. The ME152-2000 series wall plates give a professional appearance to installations. They provide a

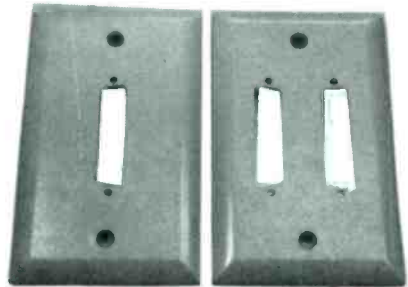

CIRCLE 974 ON FREE INFORMATION CARD

permanent, wall-mounted outlet for male or female, 25 pin (RS-232 protocol) connectors. The plates are made of durable thermoplastic, available with single or double outlet. They are ivory in color with a fine-textured finish.

A single-outlet wall plates costs as little as \$1.14 in quantities of 100.

For a free catalog write to Mouser Electronics, 11433 Woodside Avenue, Santee, CA 92071. Tel.: 619/449-2222.

## Digital Storage Oscilloscope

Leader Instruments has introduced the LBO-5825, a 35 MHz, 2-Channel Digital Storage Oscilloscope—their first! The LBO-5825 is equipped with a 2K-word memory, has a 5-MHz maximum sampling rate, and pre-trigger view capability. X-Y recorder output terminals are provided for use with a plotter, and simultaneous display of real time and stored



CIRCLE 945 ON FREE INFORMATION CARD

waveforms are possible. Other features include roll function, memory protect, external clock provision, and automatic chop alternate mode select. The LBO-5825 also has the superior sen-

(Continued on page 94)



THE BRUNELLE  
**Commander**

SERIES

Providing sine, triangle, square, pulse and ramp outputs over the 0.2Hz to 2MHz frequency ranges.

Dependability you can count on. Meets toughest demands!

Model  
3030  
Function  
Generator



Featuring

**\$459.00**

- Accuracy of  $\pm 5\%$
- VCF input
- Variable DC offset
- TTL or CMOS pulse output

- Measurement range from 0.1HZ to 10MHZ
- High input sensitivity of 20mv RMS
- 2 year warranty
- Digital display



BRUNELLE INSTRUMENTS INC.  
P.O. Box 745  
Newport Vermont 05855-0745  
Tel: 1-802-864-5505 Telex: 05-836226

CIRCLE 907 ON FREE INFORMATION CARD

**MICROWAVE TV ANTENNA SYSTEMS**

**Freq. 2.1 to 2.7 GHz . 34 db Gain +**

**COMPLETE SYSTEMS:**  
(as Pictured)

**Commercial 40"**  
Rod Style **\$99.95**

**Parabolic 20"**  
Dish Style **\$79.95**

**COMPONENTS**  
Down Converters  
(either style) **\$34.95**

Power Supplies **\$24.95**  
(12V to 16V. DC+)

Data Info (Plans) **\$ 9.95**

**CALL OR WRITE FOR  
KITS, PARTS, OR MORE  
INFORMATION**

Shipping & Handling Add \$5.00  
We Repair Most Types Down  
Converters & Power Supplies

**Phillips-Tech  
Electronics**

P.O. Box 34772  
Phoenix, AZ 85067  
(602) 967-8872

Special Quantity Pricing  
Dealers Wanted

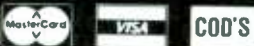

**LIFETIME LIMITED WARRANTY  
PARTS & LABOR**



CIRCLE 924 ON FREE INFORMATION CARD

# BOOKSHELF

**Confidential Frequency  
List**

By Oliver P. Ferrell

The 6th Edition of this popular book represents the latest information on communications stations operating on the shortwave bands. This is no mere reprint of data copied blindly from various official and semi-official lists, the

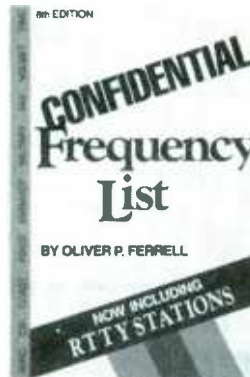

CIRCLE 973  
ON FREE INFORMATION CARD

text lists stations that are actually in operation and being heard by active monitors.

The pages are packed with data on fixed, FAX, military, aeronautical, embassy, Interpol, press, VOLMET, Costal, and hundreds of RTTY stations. All are listed by frequency and call sign (if there is one), and location, together with power (when known), and pertinent remarks about hours and schedule. Also spelled out are the internationally agreed-upon spectrum portions devoted to mobile, fixed, broadcasting, and other services.

Additional text has been included by authors Robert French, Tom Kneitel, and Webb Linzmayer, each of whom is a recognized expert in the SWL field.

This book is the last publishing effort by the author. Perry, as he was known by his friends, passed away earlier this year due to injuries received in an automobile accident. He was an intense person, both in his activities and his friendships. The quality and accuracy of this final publication cannot be truly appreciated unless the reader had the opportunity to share his workday with him when he steadfastly pursued information and its corroboration. Perry shared his lunch hour with this editor hundreds of times, during which time we talked about family and shortwave. Both subjects were easy for him to discuss because he loved both dearly. I don't know where Perry is now; but, I do know he has a pair of cans on his head and his fingers on the tuning knob.

Gilfer Associates, Inc.,  
P.O. Box 239, 52 Park  
Ridge, NJ 07656.  
Paperback, 336 pages,  
\$13.95.

**Understanding Unix: A  
Conceptual Guide**  
By James R. Groff and  
Paul N. Weinberg

Here's a fresh, comprehensive overview of the increasingly popular UNIX operating system.

(Continued on page 16)



CIRCLE 964  
ON FREE INFORMATION CARD

## Looking for a Special Part?

For that "Special Project" try the Surplus Electronic Supermarket in the heart Silicon Valley...

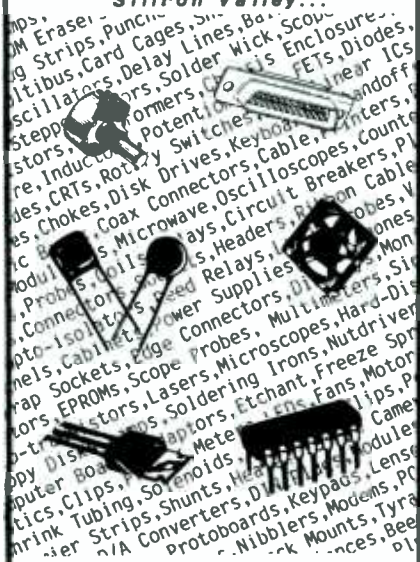

## Halted Specialties

(408) 732-1573 827 E. Evelyn Ave.  
 (415) 969-1448 Sunnyvale, Cal.  
 Visa, MC, Amex 94086

CIRCLE 922 ON FREE INFORMATION CARD

## DON'T FORGET



USE  
YOUR  
READER  
SERVICE  
CARD

## BOOKSHELF

(Continued from page 15)

The authors explain UNIX features and benefits, and describe where UNIX fits in the worlds of computing, business, and education. Major topics covered in the text include the UNIX structure, the UNIX file system, the UNIX shell, multiuser operation, turnkey processing, text processing and office support, software development, and communications. One section of the book explains different versions of UNIX, including Berkeley, System V, and XENIX.

The authors' purpose was not to provide a terminal aid for a new UNIX user, with step-by-step instructions on what to type next; instead, they presented an overall perspective of the UNIX system and the concepts that make it unique. The book seeks to answer the question, "What is UNIX and why is it suddenly attracting so much attention?"

Que Corporation, 7999 Knue Road, Suite 202, Indianapolis, IN 46250. Paperback, 240 pages. \$17.95.

### AERIAL PROJECTS By R. A. Penfold

Whether you have built a very simple shortwave receiver or have purchased a most sophisticated piece of equipment, the performance you get will ultimately depend on the



aerial (antenna) that is connected to your receiver. The subject of antennas is vast; but in this book, the author has considered practical antenna designs, including active, loop, and ferrite antennas, which give good performances and are relatively simple and inexpensive to build. The complex theory and mathematics of antenna design have been avoided.

Also included are constructional details of a number of antenna accessories including a preselector, attenuator, filters and tuning unit.

ETT, Inc., P.O. Box 240-HOE, Massapequa Park, NY 11762. Soft cover, 84 pages. \$5.00.

### 54 VisiCalc Models: Finance, Statistics, Mathematics By Robert H. Flast

Whether you're a beginning or an experienced VisiCalc program user, you'll get more out of your software by using this comprehensive collection of

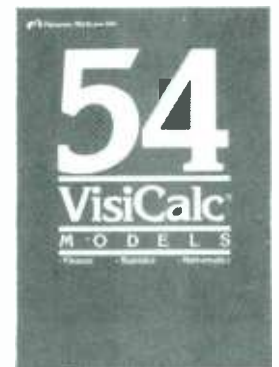

CIRCLE 943  
ON FREE INFORMATION CARD

ready-to-use VisiCalc models. Presented in a standardized format, these models are for managing investments, loans and taxes, and for solving statistical and mathematical problems. They can be keyed directly into your computer.

Some interesting applications are: Days between two dates, Students *t*-distribution, earned-interest table. Angle  
(Continued on page 96)

## 0-35dB VARIABLE GAIN RF AMPLIFIER

USES TWO REVOLUTIONARY  
NEW HYBRID  
BROADBAND AMPLIFIER ICs

Works on all RF Signals from 40-900MHz  
**All 2-VG Wired & Tested**  
 Originally Sold At \$49.95 ea.  
 Special Buy Now \$15.50 ea.



## RF MODULATOR CRYSTAL CONTROL

### 3401 SERIES

**Switchable**  
 CH 3 or 4  
 9V B+ 45 MA  
 \$17.75 ea.  
 3/\$45.50  
 Inq. for Quantity



OUTPUT "F" JACK

## Accessory Specialties

P.O. BOX 486  
 HAWTHORNE, CA 90250  
 PHONE: (213) 324-1973

WE ACCEPT MONEY ORDER, VISA, MASTER CARD  
 PERSONAL CHECK ORDERS HELD 20 DAYS NO COD  
 ADD \$3.50 for Shipping and Handling CA Residents ADD 6 1/2% TAX  
 SHIPPED VIA UPS

CIRCLE 908 ON FREE INFORMATION CARD

Train for the Fastest Growing Job Skill in America

# Only NRI teaches you to service and repair all computers as you build your own 16-bit IBM-compatible micro

As computers move into offices and homes by the millions, the demand for trained computer service technicians surges forward. The Department of Labor estimates that computer service jobs will actually *double* in the next ten years—a faster growth than any other occupation.

## Total System Training

As an NRI student, you'll get total hands-on training as you actually build your own Sanyo MBC-550-2 computer from the keyboard up. Only a person who knows *all* the underlying fundamentals can cope with *all* the significant brands of computers. And as an NRI graduate, you'll possess the up-to-the-minute combination of theory and practical experience that will lead you to success on the job.

You learn at your own convenience, in your own home, at your own comfortable pace. Without classroom pressures, without rigid night-school schedules, without wasted time. Your own personal NRI instructor and NRI's complete technical staff will answer your questions, give you guidance and special help whenever you may need it.

## The Exciting Sanyo MBC-550-2—Yours To Keep

Critics hail the new Sanyo as the "most intriguing" of all the IBM-PC compatible computers. It uses the same 8088 microprocessor as the IBM-PC and the MS/DOS operating system. So, you'll be able to choose thousands of off-the-shelf software programs to run on your completed Sanyo.

As you build the Sanyo from the keyboard up, you'll perform demonstrations and experiments that will give you a total mastery of computer operations and servicing techniques. You'll do programming in BASIC language. You'll prepare interfaces for peripherals such as printers and joysticks. Using utility programs, you'll check out 8088 functioning. NRI's easy step-by-step directions will guide you all the way right into one of today's fastest growing fields as a computer service technician. And the entire



NRI is the only home study school that trains you as you assemble a top-brand micro-computer. After building your own logic probe, you'll assemble the "intelligent" keyboard. . .

Your NRI Course Includes a Sanyo MBC-550-2 Computer with 128K RAM, Monitor, Disk Drive, and "Intelligent" Keyboard; The NRI Discovery Lab<sup>®</sup>, Teaching Circuit Design and Operations; a Digital Multimeter; Bundled Spread Sheet and Word Processing Software Worth \$1500 at Retail—and More.

system, including all the bundled software and extensive data manuals, is yours to keep as part of your training.

## 100-Page Free Catalog Tells More

Send the postage-paid reply card today for NRI's big 100-page color catalog, which gives you all the facts about NRI training in Microcomputers, Robotics, Data Communications, TV/Video/Audio Servicing, and other growing high-tech career fields. If the card is missing write to NRI at the address below.

... then install the computer power supply, checking all the circuits and connections with NRI's Digital Multimeter. From there you'll move on to install the disk drive and monitor.



**NRI** SCHOOLS

McGraw-Hill Continuing Education-Center  
3939 Wisconsin Avenue, NW  
Washington, DC 20016

We'll Give You Tomorrow.

IBM is a Registered Trademark of International Business Machine Corporation.

# Radio-Electronics

Copyright © Gernsbach Publications Inc. 1980

## SPECIAL REPRINT BUILD A BACKYARD SATELLITE TV RECEIVER



## Don't miss out again!

Send away today for your 36-page booklet containing a complete reprint of all seven articles in the series on Backyard Satellite TV Receivers by Robert B. Cooper Jr.

This all-inclusive report gives you all the data you need to build your own Backyard Satellite TV Receiver.

- TELLS ALL ABOUT domestic satellite communications, with full details on how you can pull those elusive TV signals from space.
- LEGAL REQUIREMENTS, technical specifications, and how you, the

home constructor, can meet them. Find out what mechanical and electronics skills you need.

■ RECEIVER CHARACTERISTICS, technical details and specifications, along with examples of actual receivers built at comparatively low cost.

■ ANTENNA DESIGN... and exactly how you can build a spherical antenna, while keeping total earth-station cost for the complete system under \$1,000.

■ THE FRONT END is critical when you build your own system. We help you explore several different ap-

proaches to making one that will work for you.

■ RECEIVER-SYSTEM hardware, and how it goes together to bring you direct-from-satellite TV reception in your own home.

To order your copy: Complete coupon and enclose it with your check or money order for \$7.00, plus \$1.00 for postage and handling. We will ship your reprint within 6 weeks of receipt of your order. All others add \$4.00 for postage. New York State residents must add 58c sales tax.

**Radio-Electronics**

Satellite TV Reprints  
45 East 17th Street  
New York, N.Y. 10003

Please print

HOE#3

(Name)

(Street address)

(City)

(State)

(Zip)

I want \_\_\_\_\_ reprints @ \$7.00 each, plus \$1. Handling & Postage.  
I have enclosed \$ \_\_\_\_\_. N.Y. State residents must add sales tax.

# LETTERS

## Oh Boy!

Where did I go wrong? I can't make heads or tails out of your "Electronic Coin Toss" article in the Fall 1984 issue of **Hands-on Electronics**. Can you give me some more background? H.L., Waterbury, CT

*Sure can! First off, take a peek at the corrected schematic diagram below and you'll realize that we gave you bum dope. Sorry about that. Then, add the following*

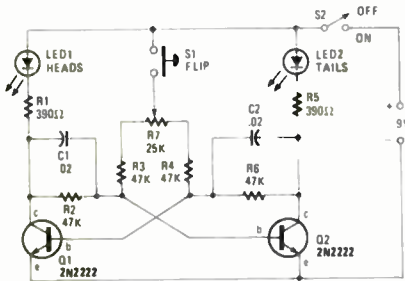

*jumpers to Fig. 2 in the original article: Add jumper between points I26 and Y26, and jumper between I14 and I18. Sorry about the goof—we fell asleep at the switch.*

## Man Made

I'd like to add some excitement to my store window. The plumbing supplier down the block has water pouring from a faucet that hangs in mid-air, defying gravity. The liquor store always has some moving display. All I have is an old Singer sewing machine in the window (I'm a tailor you know). What can I put in my window that'll stop the street traffic? M.M., Bronx, NY

*Take a look at our article on how to build a Jacob's Ladder in this issue.*

*Make one and put it in the window where no one can reach it from the inside and turn it on. Then, put a sign under it saying, "Recreate Your Clothing Here!"*

## Not the Ruissians

Who discovered electricity? C.R., Brooklyn, NY

*In the ruins of ancient Babylonia, archeologists found large earthenware jugs with carbon rods down their centers, sealed at the tops with a material no longer available, called "asphaltum." Those could only have been vintage dry cells, probably used to gold-plate Cleopatra's jewelry!*

## Good Saxon

I've got to write this letter because I think the column "Saxon on Scanners" is the finest on the subject that I have ever read. I tuned in the "utility bands" for the last 30 years long before the first scanner was on the marketplace. I used an old Gonset tunable receiver in those days. It was fun then, and it more fun now. Saxon's column probably has made more new scanner listeners that any other author's writings as far as I am concerned. Keep up the good work! L.S., Astoria, NY

*Thank you for your generous comments.*

## Wake Up!

I don't like to talk poorly of my wife. She's a fine woman and I am very proud of her. She does have one fault (we all do) and that fault is driving me crazy. She never hears the alarm clock in the morning and, therefore, sleeps through the day. What do you have that can help me? W.J., Washington Crossing, PA

*I could drop in a mess of one-liners here that'll have most of us chuckling for the next five minutes, but your problem is a serious one shared by both sexes. When I need to catch a plane, or make a*

*very important early date, I set two alarm clocks—one at bedside and the other just outside the bedroom. Thus, when they go off, I have to get out of bed to turn off the latter. Once up, I'm out of the house in ten minutes! I believe your case requires more drastic measures. So, why not trigger a British hee-haw siren (we describe one in this issue) and couple it to your high-fidelity system.*

## The Big Step

I've tried everything. I'm an avid electronics hobbyist, and my wife really resents my interest. She complains about the time I spend at the workbench, complains about the money I spend on parts, and complains about every aspect of the hobby—even when I build things that are specifically for her or for the house. Any advice on how to handle the situation?

F.S., Burley, ID

*Divorce. Some women are just plain unreasonable.*

## Crystal Radio Variation

My father once told me something about a "Fox-hole" radio. Have you any information on it?

R.S., Saskatoon, Alberta

*The Fox-Hole Radio dates back to World War II. Some stories take it back to the trenches of World War I. Soldiers, always anxious for information, began by stealing a pair of earphones from the nearest airplane or tank. One of the pair was kept intact; the other was taken apart. A coil form was made from a discarded toilet-paper core, around which the earphone coil wire was close-wound. Used as a detector was a quench-blued razor blade that served as a semiconductor, with a short piece of wire acting as a cats-whisker probe. The other earphone was connected as a listening device, and whatever wire was left served as an antenna.*

## 1920's-Style Wireless Receiver Kit

IN THE LAST ISSUE OF **HANDS-ON ELECTRONICS** (FALL 1984) we ran a construction story entitled *How to Build a 1920's-Style Wireless Receiver* that turned out to be the greatest thing since *Coca Cola*! The original article ran in *Electronics Australia* as a project-kit report. We liked that story so much that we arranged to obtain permission to present it to our readers. Mistaking believing that the kit of parts for the project would not be made available in North America, we presented the article as a construction project only. We blew it!

The people at Technicraft Electronics in Australia sent us a letter, and, after the battle among the office staff over who got the cancelled postage stamps was decided, we discovered that that company would supply a basic kit of parts, except for headphones and batteries, for \$79.50 (kit part no. 210LS). A set of headphones with high impedance goes for \$17.50 (part

no. 1940NZ). A type HL2K vacuum tube can be purchased for \$10 should you want a spare. Packing and postage to the United States via surface mail is \$12.50; surface-air, \$21.00. Payment should be made by International Money Order or bank draft in U.S. currency. Considering the distance involved (traveling both ways), you should allow for considerable time for transit. Send orders to Technicraft Electronics, 338 Katoomba Street, Katoomba, New South Wales 11780, Australia.

When you have the basic kit of parts in your hands you should have no trouble assembling the receiver in an evening. Follow the instructions we gave in the last issue of **Hands-on Electronics**.

A few readers who assembled the project from scratch informed us that a long-wire antenna produced super results, and one reader already received all the east coast states. ■

# FREE

# high tech catalog

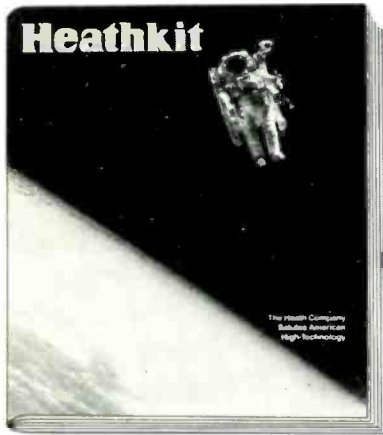

Metal Detector



Triple-Trace Oscilloscope/Time-Voltage Display

Ham Radio Transceiver



Computerized Weather Station



Real Time Spectrum Analyzer



Microprocessor Trainer & Course



Most Accurate Clock



HERO® 1 Robot

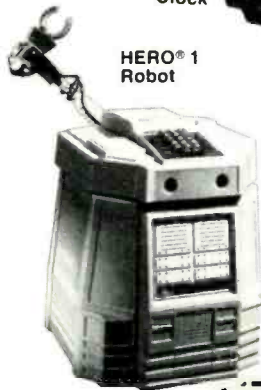

IBM-PC Compatible Computers



40-Channel Scanner



More than just a catalog, a trustworthy guide to what's new in computers and electronics.

Ever since radio grew into electronics, the illustrated Heathkit catalog has been a guide to new and exciting kit products for people like you to build. To enjoy and learn from, while saving money in the process.

What sets the Heathkit catalog apart is its range of high quality products and accurate information on every product offered. And that's a lot of products – over 450 separate items, including: Computer hardware and software • Robots • Precision test instruments • Computerized weather instruments • Solar hot water systems • Automotive and home energy products • Security devices • Color TVs and video accessories • Quality stereo components • Amateur radio gear • Educational courses that lead from the basics of electronics all the way to high tech.

## Discover the pride.

With Heathkit, you'll discover the pride of accomplishment that comes with creating handbuilt quality that is uniquely yours.

And you'll develop skills and abilities in many technologies as you follow the step-by-step directions through the building process.

You work confidently, always backed by our simple promise, "We won't let you fail."

If you don't have the latest Heathkit Catalog, you're missing something great, so mail the coupon now, while you're thinking about it.

**Send NOW for your FREE Heathkit Catalog**  
It's the beginning of something great for the whole family.

Heath Company  
Dept. 107-264  
Benton Harbor, Michigan 49022  
Please send me the latest Heathkit Catalog Free.

Name \_\_\_\_\_

Address \_\_\_\_\_

City \_\_\_\_\_ State \_\_\_\_\_

Zip \_\_\_\_\_

CL774C

**Heathkit®**  
Heath  
Company

A subsidiary of Zenith Electronics Corporation

CIRCLE 912 ON FREE INFORMATION CARD

# BUDGET ROBOTICS

Robots, the lifelike vision from our imagination, is the workman of our industry today, assembling consumer products as small as pocket radios and as large as automobiles!

By Robin J. Durriz

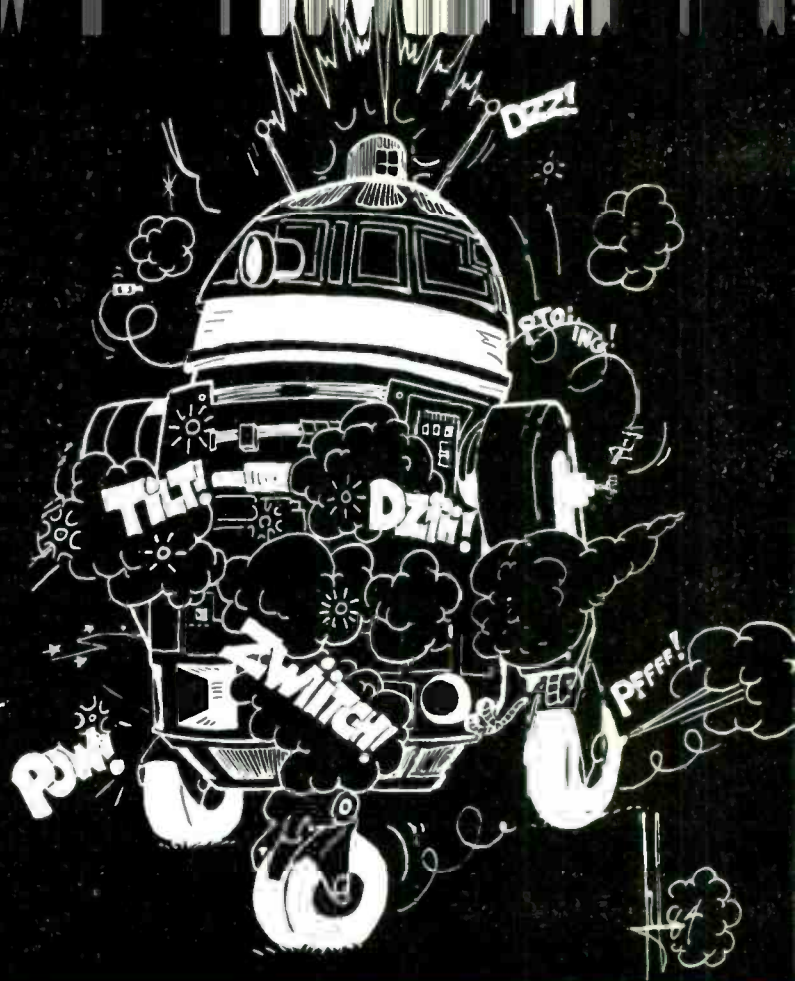

Drawing courtesy of Nation Research Council of Canada

HOBBYISTS AND EXPERIMENTERS ARE KEY PLAYERS IN today's infant robotics field. Current robots are still only pale shadows of such fictional heroes as *Star Wars'* C3PO or Robbie the Robot of *Forbidden Planet*. It only has been in the last few years that computer advances, especially the micro-processor, have made it possible to build a machine that is both programmable and mobile. While some very expensive, and mainly experimental, equipment does have advanced capabilities in fields such as vision and speech recognition, what is available to the hobbyist on a limited budget is not nearly so sophisticated.

At the same time, today's robots can be extremely valuable as a means to delve into the new and exciting field of robotics. Commercially sold kits, and even already-assembled robots, can introduce the novice to programming, or show the advanced programmer whole new applications. And problems like robot locomotion through the obstacle-filled home environment offer a real challenge, one that occupies commercial developers and garage tinkers alike. So, here, then, are some of the products available today for those anxious to be part of the future.

## Industrial Robots

It is in factory settings that robots are finding their first practical applications. Such industrial machines more resemble metallic arms than the androids of science-fiction lore. Their mobility is generally limited to movements of one or more joints, and so far they are proving most useful at single-task operations like parts manipulation, welding, handling

dangerous substances, and painting. Those robots can cost tens of thousands of dollars and up, and thus are not in the reach of hobbyists.

It is predicted that use of industrial robots in the United States will increase dramatically in the next several years. According to one report (by Prudential-Bache Securities and Daiwa Securities America), use of robots in American factories is expected to go from 8100 units in 1985 to 21,575 units (of all types) by 1990.

There are only a few low-cost robotic arms of possible interest to the experimenter. Armatron, currently distributed by Radio Shack, costs just \$31.95. It is battery-operated and controlled by two joysticks. The rubber-coated grippers can pick up, rotate, grip, move, and release. It is 14-inches tall at maximum arm extension. According to one-seventh grade science student in New Mexico, it is possible to make an interface to connect Armatron to a home computer. He spent only an added \$30, connecting six motors to control the robotic arm's six joints. Using wood as bearing blocks, he connected motor shafts to the robot's gears. He used transistors as switches to power the motors with 6-volt power supplies. A 4-bit word from his Commodore Vic-20's port is decoded into 12 lines of data. Two lines are used to give the forward and reverse commands to each motor.

For the less adventurous, it is also possible to obtain a commercially produced interface from Analog Micro Systems in Colorado.

Spectron Instrument of Denver, Colorado, sells two robotic arms. The first is called Robot I and is a two-axis

articulated arm. Under computer control, it can simulate general material handling operations as done by industrial models. Motion is accurate to  $\pm 1$  inch. Reach is 7-inches square. The gripper can carry a one-ounce load. Robot I sells for \$125 in kit form, \$210 fully assembled and tested.

Robot I is also available with vision module, called VIS. Included is a photo sensor with a close-up lens, and illuminator LED's. VIS can view a .04 inch spot on a table, can resolve black—as well as 256 gray levels. Each arm position can generate a vision input of up to 64,000, although only a few points can be examined each second. Using an interface adaptor to a home computer, and the BASIC language, data is entered using PEEK commands. The combination Robot-VIS kit sells for \$160, fully assembled \$265 (\$200/330 with computer adaptor).

Robot IV is a four-axis articulated arm, which can grip small objects and manipulate them in three dimensions. It has a two-fingered gripper, having 180-degree rotation capability. The arm can cover an area about 6 inches by 6 inches, and can carry a one-ounce load. The servo-drive circuit requires at least four analog inputs for lateral motion, lift motion, radial motion, and gripper rotation, as well as a single digital input for gripper operation.

To connect Robot IV to a home computer, two interface boards are necessary. POKE commands into five separate address locations determine arm motions. Robot IV costs \$250 for the kit, \$415 assembled. The combination package, including sensors and computer adaptors, sells for \$400 as a kit, \$660 tested and assembled.

Spectron Instrument also sells a variety of vision and

automation kits separately, plus servo motor actuators and drive circuits. For more information contact them at 1342 W. Cedar Ave., Denver, CO 80223; (303) 744-7088.

### Personal Robots—are they good for anything?

During April, 1984, more than 1000 robotics experimenters, exhibitors and other enthusiasts met in Albuquerque, New Mexico at the First International Personal Robot Congress and Exposition. Most people who spoke there seemed to agree that personal robots can't help much yet with housework, or cook dinner, or even get the newspaper—if there are any obstacles, like steps, in the way. Limited home security is one possible use for some of the more sophisticated types. Really, though, for the time being, one of the best applications for personal robots is as a tool for learning.

Robots are computers that move. Some of the biggest challenges facing the designers of home robots involve figuring out how such a machine can move effectively on different surfaces (for example, over carpet as well as linoleum), and how it might sense and react to such common obstacles as furniture, walls, doors, toys, and people.

In order to move and detect external interference, a robot must have sensors of some kind. Most commonly used are sonar, light, tactile, and to a lesser extent, heat. A robot might use one, all, or a combination of such sensors. How it responds to an obstacle, upon detection, depends on how it has been programmed.

Software is the key in robotics, just as it is for computers generally. Once certain minimal hardware requirements are met, how intelligent a robot actually behaves depends on its

### COMPARISON OF HERO I AND HERO JR.

Feature	Hero I	Hero Jr.
CPU	8-bit 6808	8-bit 6808
Memory	RAM = 4K ROM = 8K	RAM = 8K ROM = 32K (built-in routines)
Program Language	Machine language	Full pre-programmed (English) RS-232 port + BASIC cartridge
Input Devices	Hexadecimal keypad Remote control pendant RF Cassette recorder (not incl.) via serial port	17-key keypad for modifying personality Extra cartridges available
Power Supply	Rechargeable gel batteries, including external charger	Batteries operate 4-6 hrs (incl. 2) plug-in wall charger included
Movement	3 wheels Front wheel has 12 in. turning radius	3 wheels Single articulated rear-drive wheel 12V DC motor plus stepper for steering
Sonar Sensor	2 sensors; determines range and direction of object between 4-in. and 8-ft.	Ultrasonic Polaroid transceiver works with motion detector judges distances between 4-in and 25-ft.
Photo Sensor	1 sensor detects whole visible spectrum	1 256-bit resolution sensor—adjustable range 25 degree reception angle
Sound Detector Sensor	1 sensor hears sounds from 300-5000 Hz.	1 sensor with 256-bit resolution adjustable range 200-5000 Hz.
Speech	Optional synthesizer, 4 pitch levels Votrax, with 64 phonemes	Standard, 4 pitch levels Votrax, with 64 phonemes
Arm	Optional; includes gripper 5 stepper motors, 5 axis of motion opens 3½ in.; can lift 1 pound when fully extended	None
Clock	Includes calendar—real time	CMOS processor (Motorola 146818) 100-year calendar
Price	kit: \$799.95 assembled: \$2199.95 w/arm and voice	Not available About \$1000



Heath/Zenith's newest robot, Hero-Jr is for home and personal use. Using pre-programmed computer memory, Hero-Jr is ready to run a wide variety of robot routines at the push of a button.

programming. Artificial intelligence is an important field within computer science, and quite relevant to robotics. When sophisticated programs can increasingly enable robots to learn about their environment, as they experience it, these moving computers will become more capable, and so more useful. Meanwhile, the various robots on the market can demonstrate and teach about some of the current technology.

Whether Big Trak by Milton Bradley is a robot is certainly debatable. Actually it's a programmable tank. Many schools, however, are finding it an excellent—and cheap—way to introduce *robotica*, as it moves when programmed. It has been on the market for several years, and may, in fact, be hard to find. It retails for about \$75.00. Big Trak is plastic, and about 3- x 5- x 7-inches in size. It has a keyboard on top, which can be programmed for movement in any direction, using clock-minutes to signify a turn angle. Up to 16 instructions can be entered at a time, and then repeated.

### Heroes Are Like Real People

The name Heath/Zenith is not new to most electronics hobbyists. In 1983 the company, well known for its various electronic kits, introduced a sophisticated, yet affordable, personal robot, Hero I. It is currently the best-selling personal, and educational robot on the market. Heath/Zenith has just introduced a new, more consumer-oriented version, Hero-Jr.

Hero I was designed with the computer-wise experimenter in mind, to teach robotics and industrial electronics. Hero-Jr,

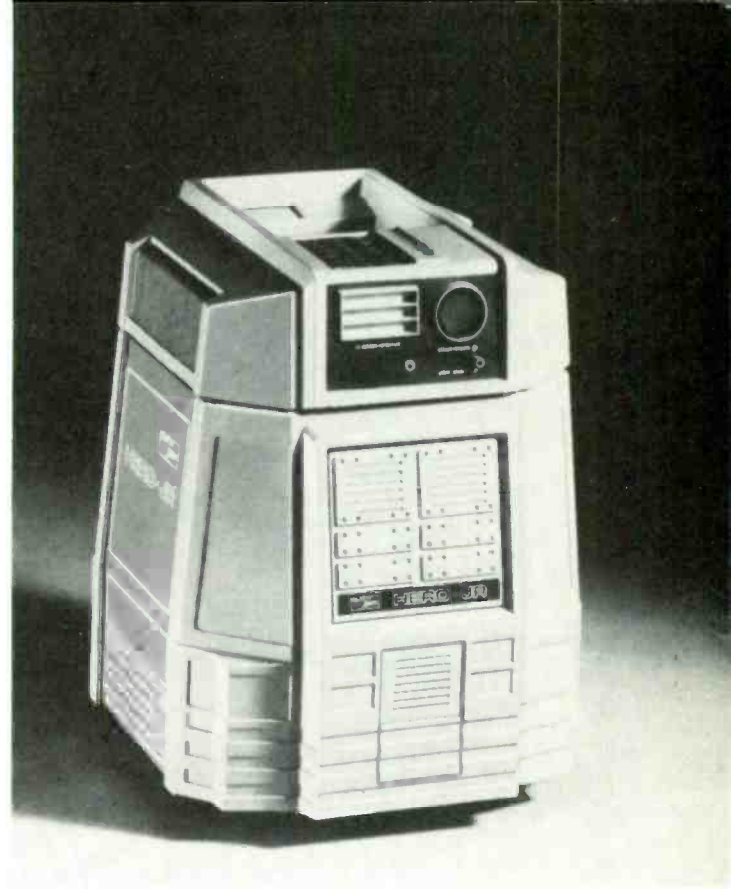

on the other hand, is directed at the home-and-family audience, with entertainment at least as important as its educational value (see chart comparing features of Hero I and Jr). Hero-Jr comes with several different possible personalities built-in. *Programming* primarily means adjusting the traits of those personalities.

Three methods of programming Hero I are possible. First, it has a hexadecimal keypad mounted on top, through which instructions can be entered. Hero-Jr, on the other hand, has replaced that keypad with a 17-key personality-adjustment keyboard. Secondly, both Heroes have a hand-held remote-control pendant to program manually-controlled motor and arm movements, although Hero-Jr has no arm. Lastly, Hero I has a serial cassette port. By connecting an ordinary cassette tape recorder here, programs can be saved and then reloaded into memory.

While Hero I cannot be connected to an external computer, Hero-Jr can. Using a built-in RS-232 communication port, and a special version of BASIC, it is possible to program Hero-Jr's speech and movements, as well as other traits.

Hero-Jr comes with a Votrax SC-01 speech synthesizer, enabling the robot to say almost anything, using four pitch levels and 64 phonemes.

Both Heroes come with sensors for detecting motion, sound and light. Hero-Jr uses 256-bit resolution sound and light sensors with adjustable ranges. The light sensor also has a 25-degree reception angle. The sonar sensor has a bandwidth of 200 to 5000 Hz. Ultrasonic sonar can measure distance from 4 inches to about 25 feet. Optional on Hero-Jr, but standard on Hero I, is the six-field infrared motion sensor.

Only Hero I can be purchased either in kit form or fully assembled. An optional arm, speech synthesizer, and a plug-

Hero I was designed as a trainer to teach robotics in school, home, and industry. In just one year after its introduction, Hero I became the largest-selling robot in the field.



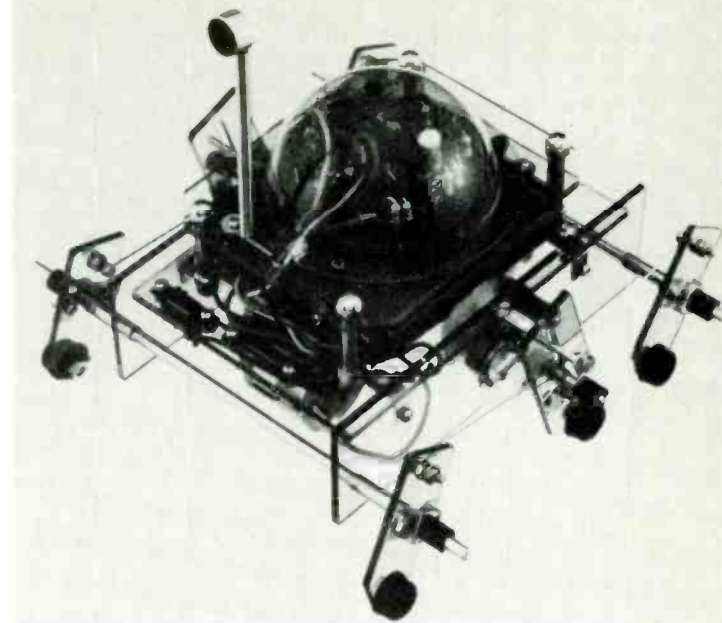
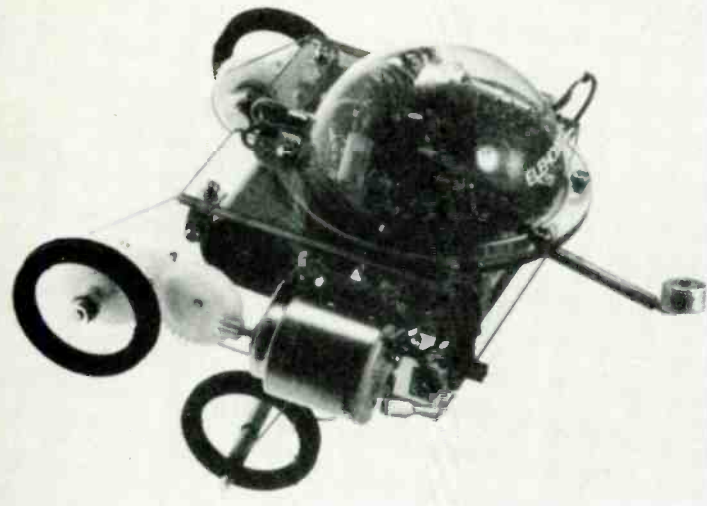

The Pipe-Mouse (above) and Turn Backer (right) are two Movit Kits you can build and operate in one day!

in demonstration ROM is available for Hero I. Speech capability is built into Hero-Jr. as he can sing songs, speak and play games. Several independent developers have produced add-on products for Hero I. It is expected that the same will soon be true for Hero-Jr, although more entertaining.

### Commercial Kits that Teach Robotics

Movit kits are inexpensive, computerized (and logic-controlled), battery-operated robot kits. They are manufactured in Japan in two forms. They come either needing both the

electronics and mechanical parts assembled, or else with the electronics already soldered and in place. Movit kits have been distributed in the U.S., since Fall 1983, and there are now 11 kits available (see chart for descriptions). According to Bruce Sanchez, President of New Tech Promotions, their major independent West Coast distributor, Avoider and Memocon Crawler are the two most popular kits. His favorite is the newest kit, Circular. The 11 kits (so far) teach the fundamental principles of robotic sensing and locomotion.

One of the simplest, called Turn Backer, includes a small  
*(turn to page 30)*

### MOVIT KITS

Name	Movement	Control	Batteries Required (not included)	Price (mech. assy/mech + electronics)
Turn Backer	3 legs on each side—crank motion	sound sensor including condenser microphone	4—1.5-V "AA" 1—9-V	\$39.95
Piper-Mouse	3 wheels driven by 2 DC motors	super sonic sound sensor including condenser mike	2—1.5-V "AA" 1—9-V	\$44.95
Sound Skipper	2 alternatively moving legs driven by crank motion	sound sensor including condenser mike	2—1.5-V "N"	\$24.95
Peppy	3 wheels driven by 2 DC motors	2-way sensor, responds to sound and solid objects in path	2—1.5-V "AA"	\$24.95/\$18.95
Memocon Crawler	3 wheels driven by 2 DC motors	Memory/electronics circuit through keypad—4-bit static RAM	2—1.5-V "AA" 1—9-V	\$74.95/\$46.95
Avoider	3 legs on each side crank motion	Infrared sensor including infrared diode/photo diode/IC	4—1.5-V "AA" 1—9-V	\$44.95
Line Tracer II	3 wheels driven by 2 DC motors	Infrared sensor incl. infrared diode/photo diode/IC	2—1.5-V "AA" 1—9-V	\$39.95/\$28.95
Monkey	2 alternatively moving gripper arms driven by crank motion	sound sensor including condenser mike	2—1.5-V "N"	\$24.95
Mr. Bootsman	6 legs—2 speed movement	control box	2—1.5-V "AA"	\$30.95
Circular	2 large wheels	hand-held remote control box	3—1.5-V "AA" 2—9-V	\$67.95
Medusa	2 legs on each side crank shaft	sound sensor including condenser mike	2—1.5-V "N"	\$27.95

# WITH CIE, THE WORLD OF ELECTRONICS CAN BE YOUR WORLD, TOO.

Look at the world as it was 20 years ago and as it is today. Now, try to name another field that's grown faster in those 20 years than electronics. Everywhere you look, you'll find electronics in action. In industry, aerospace, business, medicine, science, government, communications—you name it. And as high technology grows, electronics will grow. Which means few other fields, if any, offer more career opportunities, more job security, more room for advancement—if you have the right skills.

## SPECIALISTS NEED SPECIALIZED TRAINING.

It stands to reason that you learn anything best from a specialist, and CIE is the largest independent home study school specializing exclusively in electronics, with a record that speaks for itself. According to a recent survey, 92% of CIE graduates are employed in electronics or a closely related field. When you're investing your time and money, you deserve results like that.

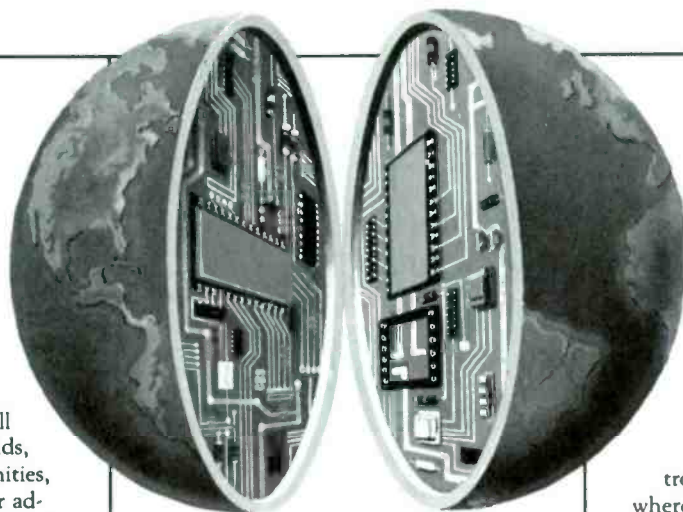

## INDEPENDENT STUDY BACKED BY PERSONAL ATTENTION.

We believe in independent study because it puts you in a classroom of one. So you can study where and when you want. At your pace, not somebody else's. And with over 50 years of experience, we've developed proven programs to give you the support such study demands. Programs that give you the theory you need backed with practical experience using some of the most sophisticated electronics tools available anywhere, including our Microprocessor Training Laboratory with 4K of random access memory. Of course, if you ever have a question or problem, our instructors are only a phone call away.

## START WHERE YOU WANT, GO AS FAR AS YOU WANT.

CIE's broad range of entry, intermediate, and advanced level courses in a variety of career areas gives you many options. Start with the Career Course that best suits your talents and interests and go as far as you want—all the way, if you wish, to your Associate in Applied Science Degree in Electronics Engineering Technology. But wherever you start, the time to start is now. Simply use the coupon below to send for your FREE CIE catalog and complete package of career information. Or phone us at 1-800-321-2155 (in Ohio, 1-800-362-2105). Don't wait, ask for your free catalog now. After all, there's a whole world of electronics out there waiting for you.



**Cleveland Institute of Electronics, Inc.**

1776 East 17th Street  
Cleveland, Ohio 44114  
216-781-9400

A half century teaching electronics.



**CIE** **Cleveland Institute of Electronics, Inc.**  
1776 East 17th Street, Cleveland, Ohio 44114

RA-05

YES...I want to learn from the specialists in electronics—CIE. Please send me my FREE CIE school catalog, including details about CIE's Associate Degree program, plus my FREE package of home study information.

Print Name \_\_\_\_\_

Address \_\_\_\_\_

City \_\_\_\_\_ State \_\_\_\_\_ Zip \_\_\_\_\_

Age \_\_\_\_\_ Area Code/Phone No. \_\_\_\_ / \_\_\_\_\_

Check box for G.I. Bill bulletin on educational benefits:  Veteran  Active Duty  
**MAIL TODAY!**

Tomy Toys introduces *tomorrow's technology at play* with the loveable little Ding-bot (left), Omni-bot (center), a pre-programmable electronic robot with an on-board microcomputer and tape deck (center), and Ver-dot (right), a voice-activated robot that responds to eight separate verbal commands.

(Continued from page 26)

condensor microphone. Movement is by crank motion of the three legs on each side. Upon *hearing* a sound, the robot immediately turns to the left.

Line Tracer II, guided by an infrared light sensor, automatically follows a black line drawn on white paper.

Memocon Crawler is memory-controlled through an included 5-button keypad that can be programmed to move the robot forward, right, left, to pause, to sound a buzzer, and to light an LED (light-emitting diode). The robot uses a sequence function static RAM (random access memory) of 256 × 4 bit memory. It is also possible to connect a microcomputer to the same port used by the keypad in order to do more sophisticated programming. Direct connection isn't possible because a computer's signal is too fast, and has to be slowed down, which is what the interface does. It is available through Graymark (Box 5020, Santa Ana, CA 92704, 800-854-7393) for \$29.95 in parallel, or \$39.95 in serial.

The newest of the Movit kits, approved by the FCC and released last August, is Circular. Use of this kit's hand-held remote-control box allows for wireless programming. All movements of Circular's two large, independent outboard wheels are so controlled, and the system can be made to navigate very tight courses.

Presently only three of the Movit kits are available as electronics and mechanical kits; Peppy, Line Tracer II, and Memocon Crawler. They can be obtained through Graymark. To order any of the II kits, requiring only mechanical assem-



bly, contact New Tech Promotions (2265 Westwood Blvd., Suite 248, Los Angeles, CA 90024; or telephone 213-470-8383).

Another new robot, available for the first time in the U.S. Autumn, 1984, is called Omni-bot. It is being introduced by Tomy Corporation, also the first U.S. distributor of Armatron, now mainly distributed by Radio Shack (mentioned earlier). Omnibot stands two feet tall, and includes an on-board Japanese-made microprocessor, cassette deck, remote-control transmitter, digital alarm clock, microphone, two arms, and one manual grasping hand. The robot can be programmed, using the transmitter, to repeat up to seven different programs at designated times, and up to seven days in advance. Move-sequence instructions can be stored on audio cassette tape and played back to repeat movements. There are no on-board decision-making capabilities or sensors. Although not constructed with this in mind, it would perhaps be possible for an innovative experimenter to add some kind of programmable memory. The easiest way might be to disconnect the tape player, and then use the same memory locations. As Omnibot only costs \$250, such a redesigned unit would be a definite bargain.

### Hobby Robots Offer Unlimited Possibilities

In the past, before microprocessors and other IC chips, early roboticists had to use relays and other cumbersome techniques to build a functional robot. Today we not only have a variety of chips with speech, memory, and other processing capabilities, but we have small complete computers that are inexpensive, and valuable. For instance, the Timex/Sinclair ZX--81, at around \$50, makes an excellent, compact combination robot brain, memory and input device.

The desire to create life from the non-living, be it protoplasm or metal parts, is not a new pursuit of ours. Back in old Greece, myth has it that the sculptor, Pygmalion, made a beautiful woman, Galatea, out of clay, and then begged the goddess Athena to breath life into her. Then there is the often retold story of Dr. Victor Frankenstein, who regretted his life-giving cleverness not long after his monstrous creation got up from the operating table. Building robots, then, is part of a long and interesting tradition.

For now, limited budgets, as well as limited sophistication, probably precludes our robotic creations questioning their treatment and turning on us. Be advised, though, that the future is rapidly approaching. ■

Sound-sensitive Medusa by Movit looks like a walking plastic barbecue cooker coming to get you! Two legs on each side advance the robot that is sound-controlled by the operator.

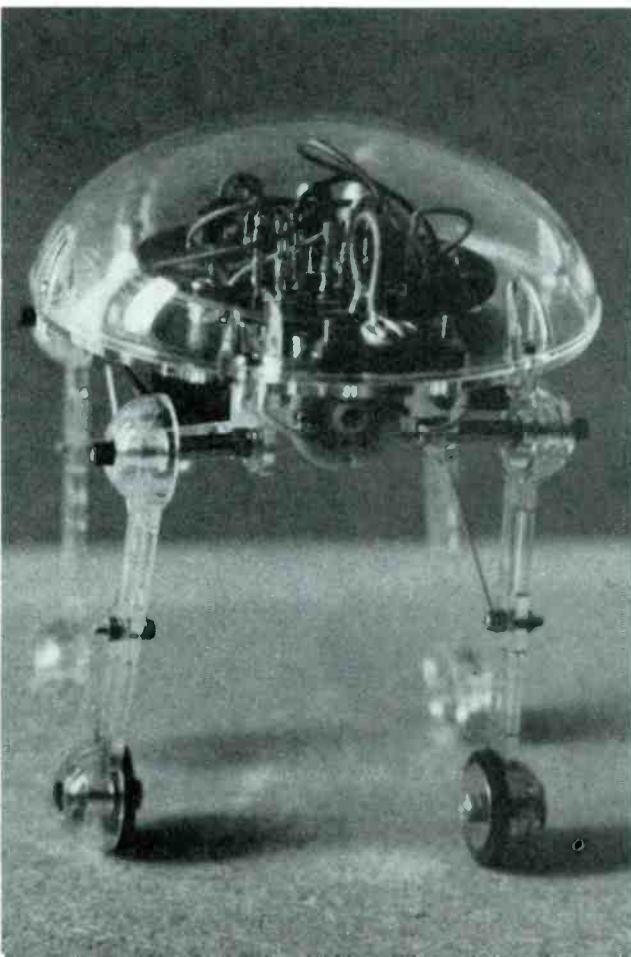

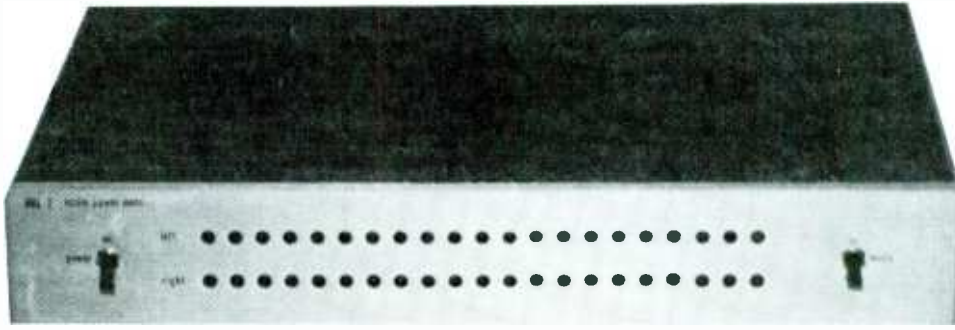

# STEREO POWER METER

The LM3914 dot/bar display driver is the heart of this meter. The LED's offer a wide-scale visual readout that adds to your listening pleasure.

By George Hadgis

☐ EXPOSING YOUR HI-FI'S SPEAKERS TO A POWER THAT EXCEEDS their maximum rating could cause permanent damage to them as well as to the system itself. Needless to say, that expense usually amounts to more than pocket money! Now,

thanks to the LM3914 Dot/Bar display-driver integrated-circuit (IC) chip, you can build an audio power meter to monitor the power going through each channel and relieve yourself of the fear of damaging your system.

The parts needed to build the Stereo Power Meter is readily available from just about all electronics supply sources for around 35 dollars. The project takes about a week to build. When completed, the Stereo Power Meter is quite eye-catching while providing an informative power-delivery display. The specifications for the Stereo Power Meter are given in Table 1.

At the heart of the Stereo Power Meter are four LM3914 display-drivers (See Fig. 1). The LM3914 chips sense analog voltages and in turn drive ten LED's connected to each chip.

**TABLE 1**  
**SPECIFICATION FOR STEREO POWER METER**

<b>Semiconductors:</b>	4-LM3914 and 1-7805 integrated-circuit chips
<b>Controls:</b>	POWER switch, MODE switch
<b>Power Source:</b>	117-VAC, 60-Hz at 73 mA
<b>Power Consumption:</b>	8.5 watts
<b>Display:</b>	Bar or dot—programming via pin 9 on LM3914 21 LED's per channel Each LED is a 5% change in RMS volts
<b>Range:</b>	As determined by setting of R1 through R6
<b>Dimensions:</b>	13- W × 2- H × 8-inches D
<b>Weight:</b>	3.4 pounds

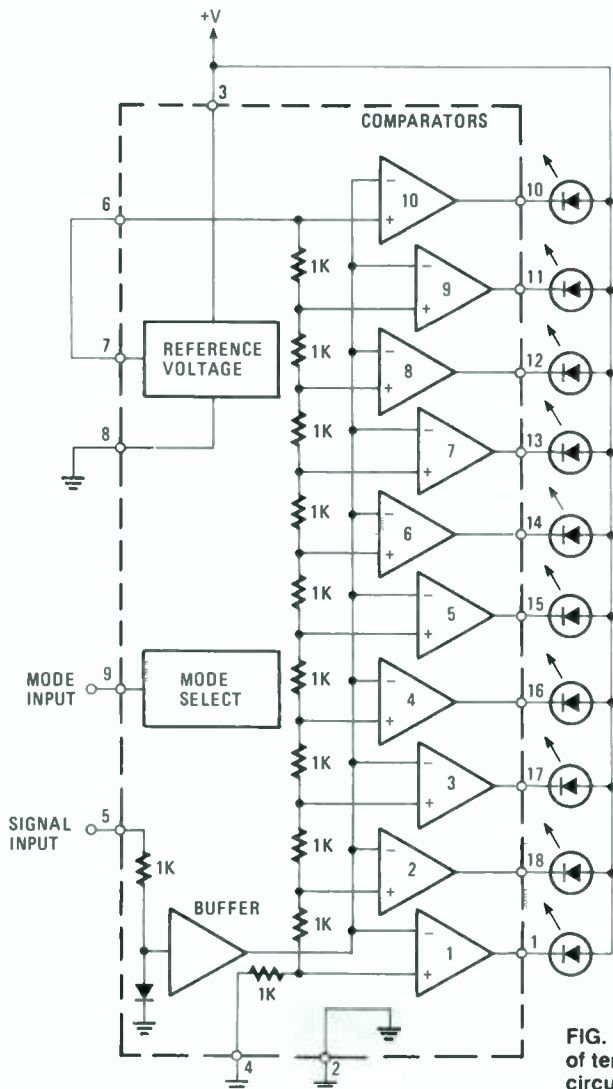

**FIG. 1**—The LM3914 integrated-circuit chip is actually made of ten comparators, a precision resistive network, buffer circuit, reference voltage source, and mode-select feature.

Those LED's provide an indication of the amount of voltage (and, hence, power) being delivered from an audio amplifier at that instant. By using two LM3914 chips per channel, you will be able to monitor the power going to each speaker, allowing you to balance your speakers, as well as providing an indication as to whether you have audio-system volume too high, resulting in excessive power being delivered on signal peaks to the speakers.

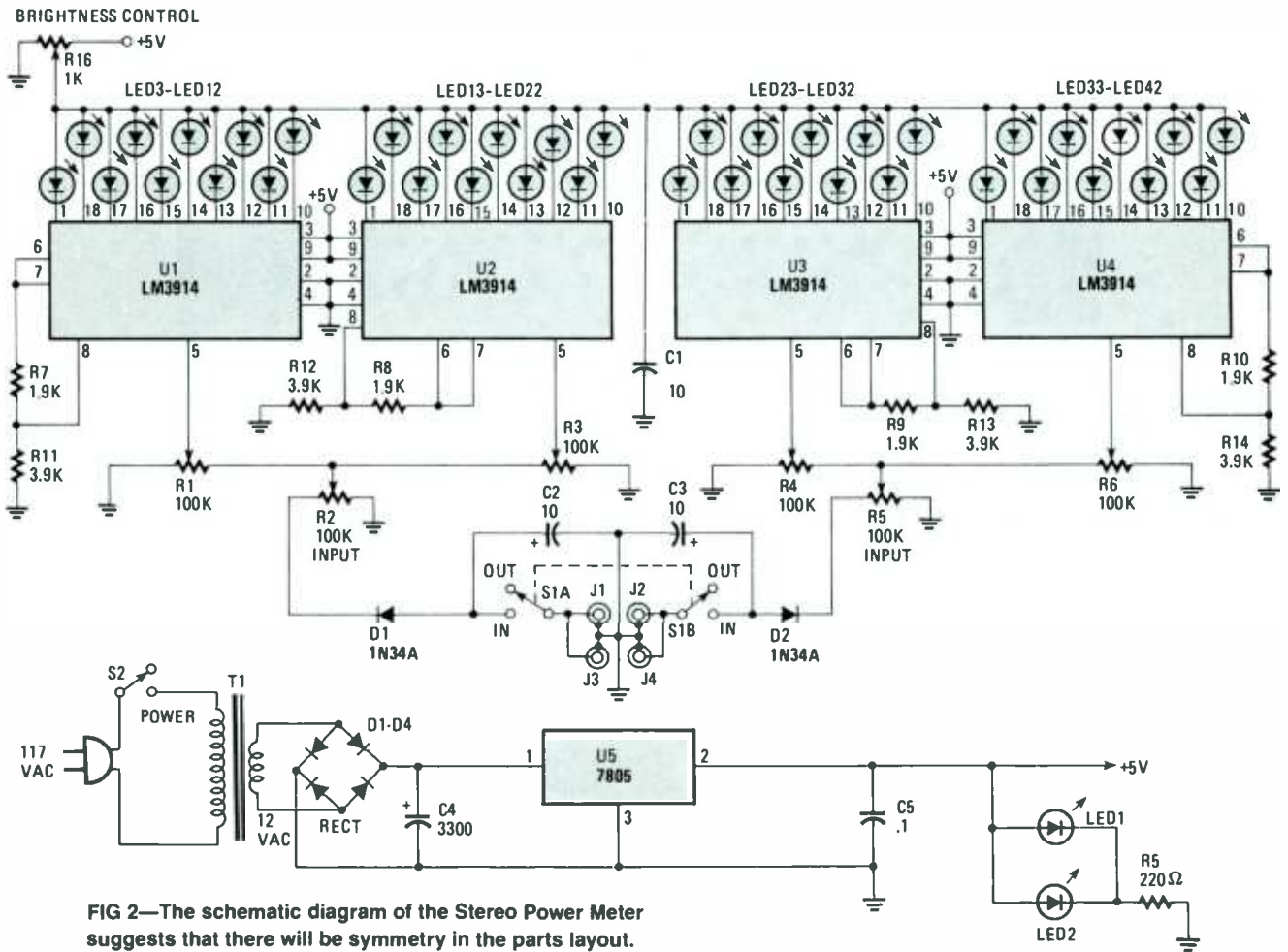

FIG 2—The schematic diagram of the Stereo Power Meter suggests that there will be symmetry in the parts layout.

The LM3914 chip has a built-in feature that allows you to select a bar display or dot display. In this project the bar display was selected because it offered a better means of comparing two visual outputs to each other.

Most of the Stereo Power Meter's circuit is built into the chip. The chip has a wide range of operating voltages from less than three volts to a maximum of twenty-five volts with a direct-current power source.

### About the Circuit

The Stereo Power Meter is made up of two identical (Fig. 2) circuits and a power supply. Each circuit contains two LM3914 display chips (U1-U4), which contain ten voltage comparators, a ten-step voltage divider, a reference-voltage source, and a mode-select circuit that selects a bar or dot

display via a logic input at pin 9. Pin 9 on U1-U4 is tied to the +5-volt regulated DC bus so that the bar display comes on. The brightness of the LED's is controlled by the 1900-ohm resistors (R7-R10) and the reference voltage is controlled by the 3900-ohm resistors (R11-R14).

The ten-step voltage divider within the chips are connected between the reference voltage and ground. Since each step of the voltage divider is separated by a 1000-ohm resistor, each comparator senses a voltage ten percent greater than the preceding comparator. The signal is applied to pin 5, which is buffered through a resistor-diode network and then amplified as it passes to each of the ten comparators. Each LED is grounded through the comparators (U1, U2, U3, U4—LM3914) as the input signal voltage matches the reference voltage. That results in one to ten LED's illuminating as the signal voltage increases.

By using potentiometers R1 through R6 (Fig. 2) between the signal input and the chip, the signal voltage applied to each chip can be controlled. That lets you use the unit as a monitor for any sound system except those which provide a low-power output. The chip is sensitive enough to respond to RMS voltage as low as 0.5 volts, thus giving your power meter a wide range of power to monitor. If you use a second set of potentiometers connected to a switch on the front panel (Fig. 3), the Stereo Power Meter will then be able to read in two scales, but that is up to you.

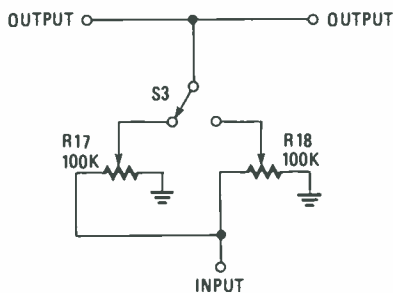

FIG. 3—An option that you may want to add is wiring the Stereo Power Meter to read in two scales rather than one.

### Construction

Because of the simplicity and the minimal amount of parts

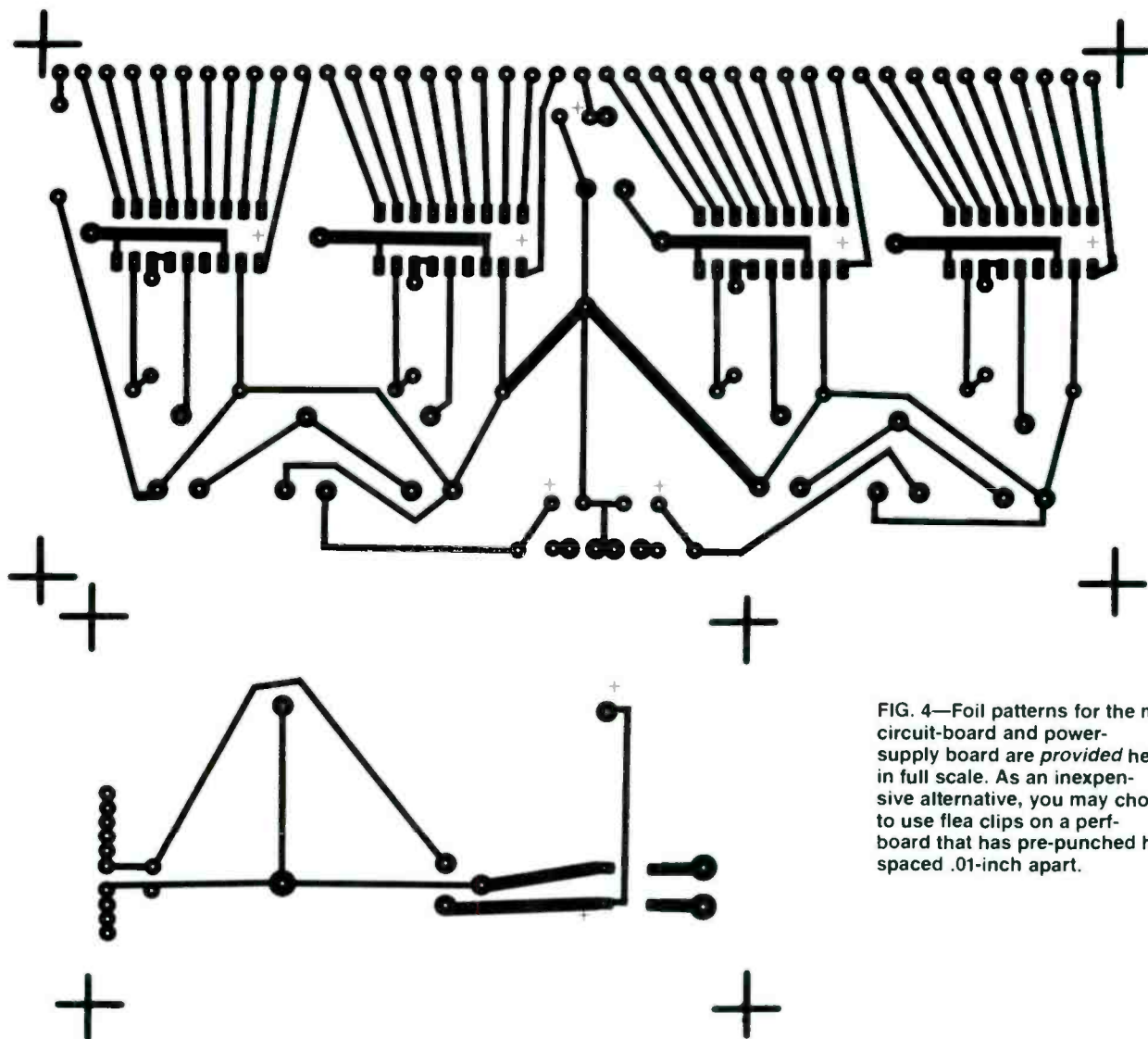
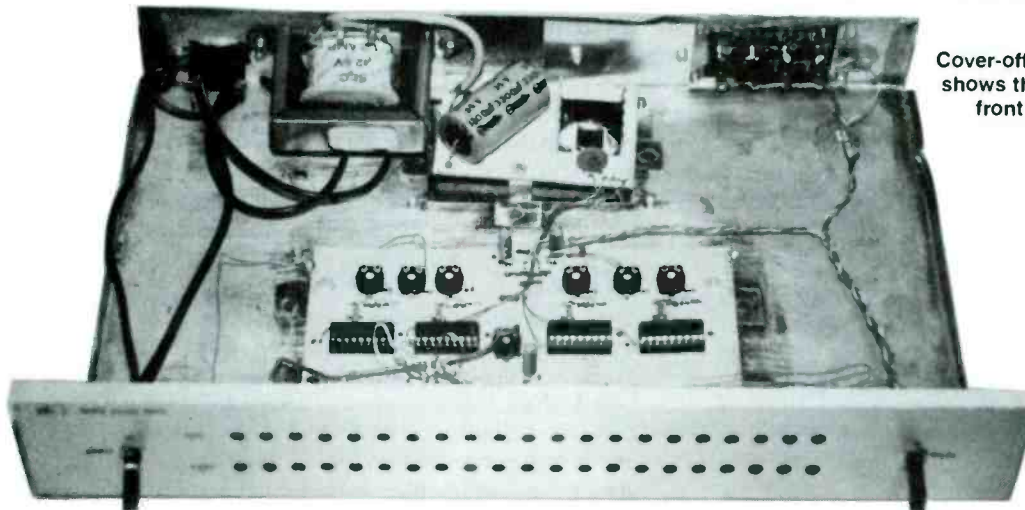

FIG. 4—Foil patterns for the main circuit-board and power-supply board are provided here in full scale. As an inexpensive alternative, you may choose to use flea clips on a perf-board that has pre-punched holes spaced .01-inch apart.

of the circuit, you may construct the Stereo Power Meter circuit in any fashion. I chose to make printed-circuit boards (main-circuit board and power-supply board) since that would give the neatest results. See Fig. 4 for same-size patterns for the boards. Laying the boards out and putting them in the etchant takes about an hour, should you be set up to do this work. (The Editor believes that it would be easier to

use a perf-board with holes drilled on .01-inch centers. The layout could be identical to the author's board and the mess of etching a PC board would be avoided. However, should you decide to make more than one Stereo Power Meter, the printed-circuit method is best!)

Once the main-circuit board is made and the holes have been drilled, the resistors, capacitors, diodes, and potenti-



Cover-off view of the Stereo Power Meter shows the main printed-circuit board up front close to where connections are made to the LED's. The power-supply board is in the rear. An accessory AC outlet was added on the extreme left of the rear apron—that is optional. The power transformer is located away from audio circuits.

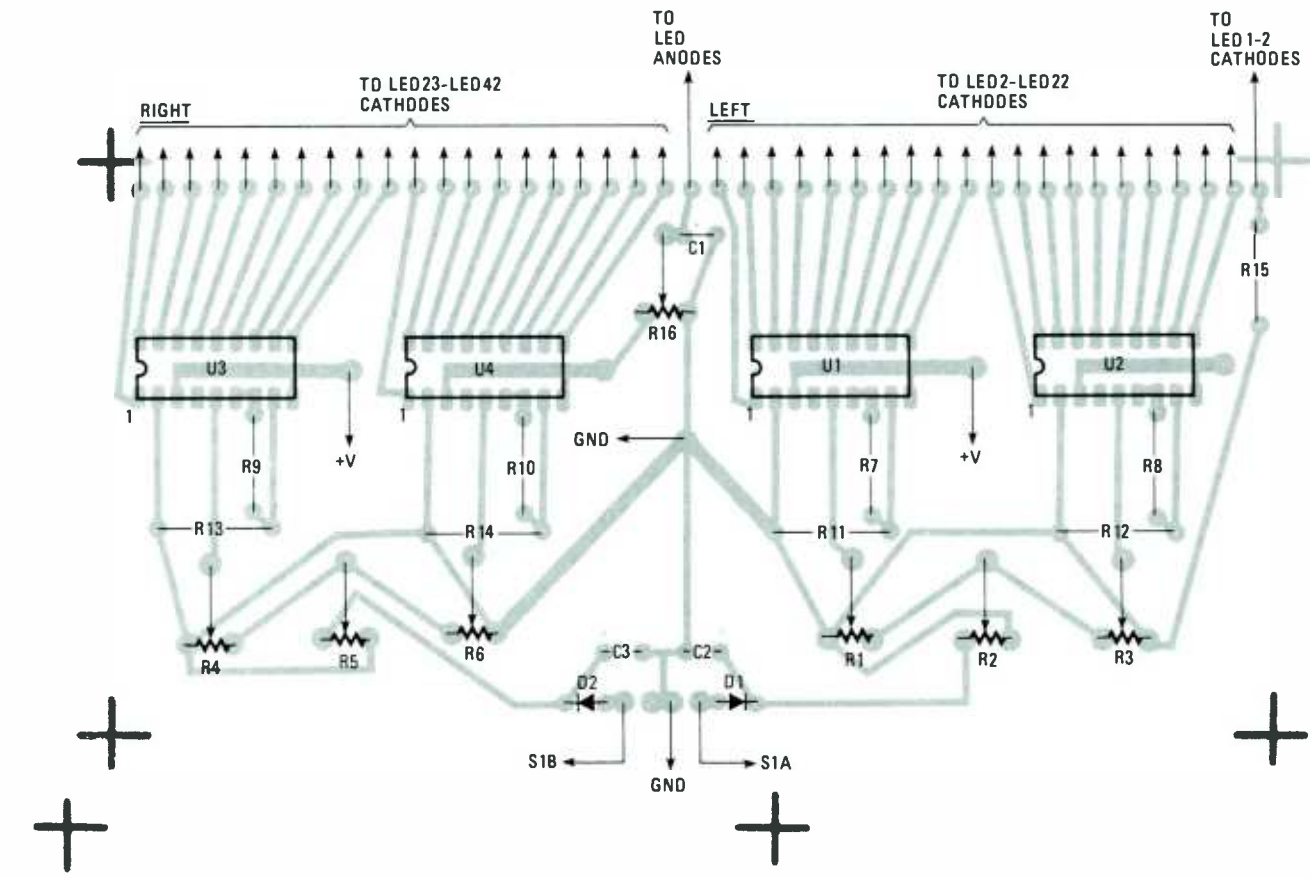
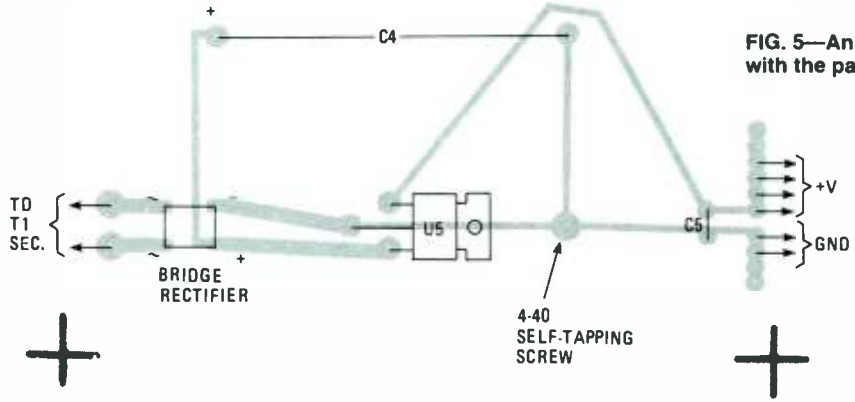

FIG. 5—An x-ray view of the main-circuit board is shown here with the parts placed in position on the non-foil side.



ometers are mounted. (See Fig. 5.) When mounting the electrolytic capacitors, be sure to observe the positive polarity markings. Also, observe the bands on the diodes—to be sure that they are not mounted backward.

It is recommended you use IC sockets on the main-circuit board and do not solder the LM3914 chips in place. The chips are highly susceptible to static electricity and stray AC voltage. If you use sockets, mount them at this time, but leave the chips in their static-free packages until the project is finished. If you don't use sockets, leave the chips in their packages until all of the other construction details are completed. Once all the components have been mounted on the circuit board, check the assembly to be sure that there are no solder bridges, and then set it aside.

Now mount the LED's on what you plan to use for the faceplate of the Stereo Power Meter. I had a friend, who works in a metal shop, cut my faceplate from a block of aluminum. Once the plate was cut, the holes were drilled for the LED's and switches. Then, with a fine grained sandpaper, it was sanded to simulate the brushed aluminum on my

system. I then lettered it and sprayed it with a lacquer to avoid discoloration. Once all the LED's are mounted, you can solder a common bus to the anode of each LED. Finally, you can mount the switches and set the plate aside for the time being.

The power-supply board can now be assembled. The power-supply output is 5-volt regulated DC. The power-supply board may be a perf-board, purchased printed-circuit board, or one of your own design (see Figs. 4 and 5). Mount transformer T1 on the chassis. Once the power-supply board is done, it may also be put aside.

The chassis is made of 20-gauge sheet metal with access panels so that you can reach the bottom of the boards without any difficulties. After the chassis has been cut out, you can mount the boards, faceplate, transformer, and jacks. Now you are ready to connect wires to each part to complete the circuit. First run a wire from each cathode of the LED's to its corresponding hole and solder them in place. Be sure that those wires go where they belong, otherwise the display will not operate properly. In order to complete the circuit, solder the power supply wires in place and connect the jacks to the boards. Now that the circuit is complete, make a final check to be sure that there are no solder bridges and that all the wires are in their proper holes. If everything checks out, then you should have no trouble during the calibration of the unit.



## Take Care

To make the unit operational, you must now insert the chips. In order to avoid static electricity discharging from your body, remove the integrated circuit from its package with both hands. While holding the chip in one hand, remove the conductive foam with the other and straighten any bent pins. Continue holding the chip in one hand, being careful not to touch to anything while you hold the board in the other. See Fig. 6.

Align pin 1 of the chip with the notch on the socket, which in turn should be aligned with the dot indicating pin 1 on the printed-circuit board. Carefully push the chip into the socket being careful that the pins do not fold underneath the chip and that all the pins go into their proper holes. Once the chip is in place, it is protected to a degree from static electricity. That concludes the construction of the Stereo Power Meter.

## CALIBRATION

Before you can calibrate the Stereo Power Meter, you need to know the maximum power rating of your loudspeaker. That is the continuous power rating (RMS) of each amplifier. Now, you can easily compute the value of the maximum voltage output of the loudspeaker signal for your system by the relationship:

$$E = \sqrt{P \times R}$$

where E is the maximum permissible RMS voltage across the speaker, P is the maximum power of the speaker in watts, and R is the impedance of speaker in ohms. (Note that the meter is calibrated to indicate overloading of the speaker. That is done because, in most cases, the system's speakers can be overpowered by the amplifier's output, causing damage to the speakers. When very low-impedance speakers are used, it is possible that the amplifier would attempt to deliver more power than it is designed to do. Then, the calibration would be preset to protect the amplifier and not the speaker. However, always make sure that the limits selected will always protect both by being at the limit of one and below the other.)

Once you have determined the power rating of your system, you are ready to calibrate the Stereo Power Meter. To calibrate it, you will need an audio oscillator that can produce

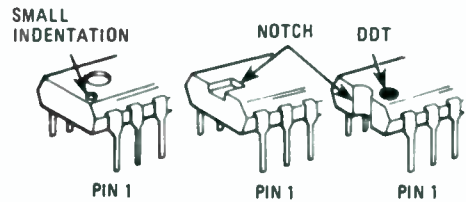

FIG. 6—Ways of identifying pin 1 on the integrated-circuit chip are shown here. If you are not careful, the chip can be installed incorrectly and destroyed when power is applied.

a signal around 100 Hz. That will be used to drive your audio amplifier for calibration purposes. You will also need a resistor to simulate your speakers. The value is not critical and can be anything in the range of 10 ohms to 50 ohms. It is important however, that you use a resistor that can handle the power at which you will be calibrating the unit. In order to measure the voltage going across the load, an AC voltmeter will also be needed.

Apply power to the unit. At this time, LED1 and LED2 should light. If they do not light, check your wiring to be sure that power is going through the circuit and to the LED's. If they light, turn R1, R2, R4, and R5 fully to the left and R3 and R6 fully to the right. Now apply the signal (Fig. 7) from

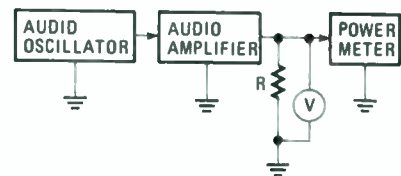
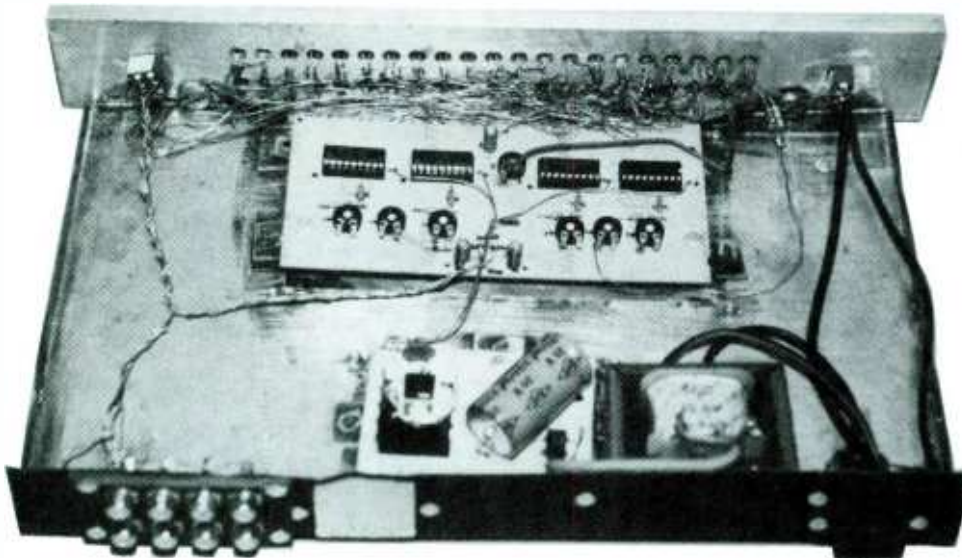

FIG. 7—Test setup to calibrate the Stereo Power Meter is diagramed here. Once one audio channel has been calibrated, repeat the calibration process on the other audio channel.

the oscillator to the amplifier. Connect the power meter, voltmeter, and load resistor ( $R_1$ ) as shown. Adjust the volume control on the amplifier until the voltmeter reads the same value as the value you calculated for the RMS voltage in the equation above or the value you were given in the specifications of your stereo system. Adjust R1 and R4 so LED12 and LED32 just turn on. If R1 and R4 have no effect at all on the LED's then adjust R2 and R5 to lower the voltage going into the unit to the range the chips were designed to respond and



This view of the Stereo Power Meter shows best the connection of the main printed-circuit board to the front-panel LED's. Wire the lower set of LED's otherwise they will be difficult to hook-up later. The audio jacks and switches are kept on the left side of the chassis in this view, and the AC lines are far removed to the right side.

## PARTS LIST FOR STEREO POWER METER

### SEMICONDUCTORS

D1, D2—1N34A germanium diode  
 D3-D6—Full-wave bridge rectifier, 50-PIV, 1-A minimum, or four diodes of comparable specifications  
 LED1-LED42—Light-emitting diode, 20 mA, red  
 U1-U4—LM3914 bar/dot display-driver integrated circuit  
 U5—7805 5-volt voltage regulator, 1-A integrated circuit

### CAPACITORS

C1-C3—10- $\mu$ F, 35-WVDC, electrolytic  
 C4—3300- $\mu$ F, 35-WVDC, electrolytic  
 C5—0.1- $\mu$ F, 50-WVDC, ceramic disc

### RESISTORS

R1-R6—100,000-ohm potentiometer, PC mount  
 R7-R10—1900-ohm, 1/4-watt, 10%

R11-R14—3900-ohm, 1/4-watt, 10%  
 R15—220-ohm, 1/4-watt, 10%  
 R16—1000-ohm potentiometer, PC mount

### ADDITIONAL PARTS AND MATERIALS

J1-J4—phono jacks, RCA-type  
 S1—SPDT, toggle or slide switch  
 S2—SPST, toggle or slide switch  
 T1—Power transformer, 117-VAC pri. winding; 12.6-VAC 1.2-A sec. winding  
 Printed-circuit materials or perfboard, 13- $\times$ 2- $\times$ 8-in. aluminum chassis, decals, wire, solder, IC sockets, hardware, etc.

### PARTS FOR CIRCUIT OPTION

R17, R18—100,000-ohm potentiometer, PC mount  
 S3—DPDT, toggle or slide switch

then readjust R1 and R4. Once that is done, adjust R3 and R6 so that LED19 and LED40 illuminate. By that adjustment the last two LED's of each channel (LED21, LED22, LED41, and LED42) will not come on except when the loudspeakers are overdriven.

Now adjust the audio amplifier until LED13 and LED33 just turn off and adjust R1 and R4 once more until LED12 and LED32 illuminate. That completes the calibration of your power meter. By adjusting the volume on your audio amplifier, LED2 to LED22 and LED23 to LED 42 should respond to the input signal. Should it be desired to change the range of the unit, all that needs be done is readjust R2 and R5. The final step is to put the access panels and cabinet in place.

### Use of the Meter

Connect the Stereo Power Meter across your speakers (Fig. 8) and turn the meter and your audio system on. By adjusting the system's volume, the LED's should light in response to the power going to your speakers. With your new audio power meter, you can adjust the balance of your speakers (when in

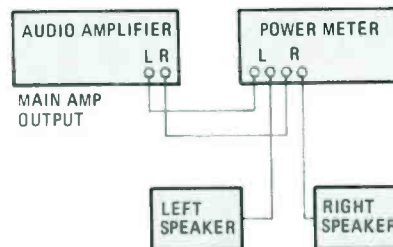

FIG. 8—Your new Stereo Power Meter is connected in parallel to your present audio system's speaker terminals. No special wiring is needed—ordinary #22 stranded hook-up wire will do.

the mono mode) and watch the levels to be sure that the system is not being overdriven. The chips respond linearly to voltage and not to power. For example, when 70 percent of the LED's illuminate, then 70 percent of the maximum RMS voltage is being delivered to the speakers—and that is equal to 49 percent of the power.

If you need to know the value of each LED in watts, refer to Table 2. The values in the Table 2 are calculated by the equation:

$$P_n = [(n-1)/2]^2 \times (P_{MAX} \div 100)$$

where  $P_n$  is the power for nth LED illuminated and  $P_{MAX}$  is the maximum power meter was preset to indicate.

### In Case of Trouble

If you have trouble getting the Stereo Power Meter to work, check all wires from jacks, boards, and power supply. Make sure that power is going to the board and the signal is reaching the main board. Take the access panels off and check to see if

(Continued on page 104)

TABLE 2—LED POWER INDICATION

Number of LED Illuminated	Percent of Power Indicated	Number of LED Illuminated	Percent of Power Indicated
1	0.0	11	25.0
2	0.3	12	30.3
3	1.0	13	36.0
4	2.3	14	42.3
5	4.0	15	49.0
6	6.3	16	56.3
7	9.0	17	64.0
8	12.3	18	72.3
9	16.0	19	81.0
10	20.3	20	90.3

The rear apron of the unit shows eight jacks, four of which are not connected. Light-colored square is a patch covering a hole made for a prior project.

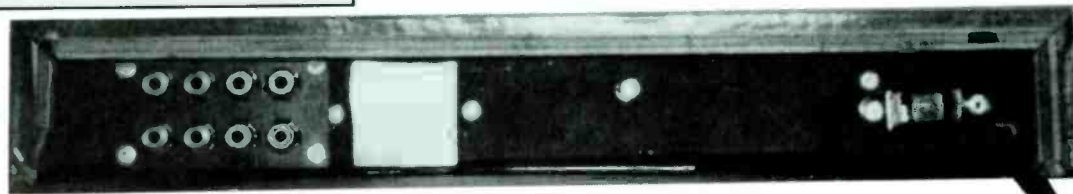

The IBM-compatible NTS/Heath HS-151 PC is included in three training programs.

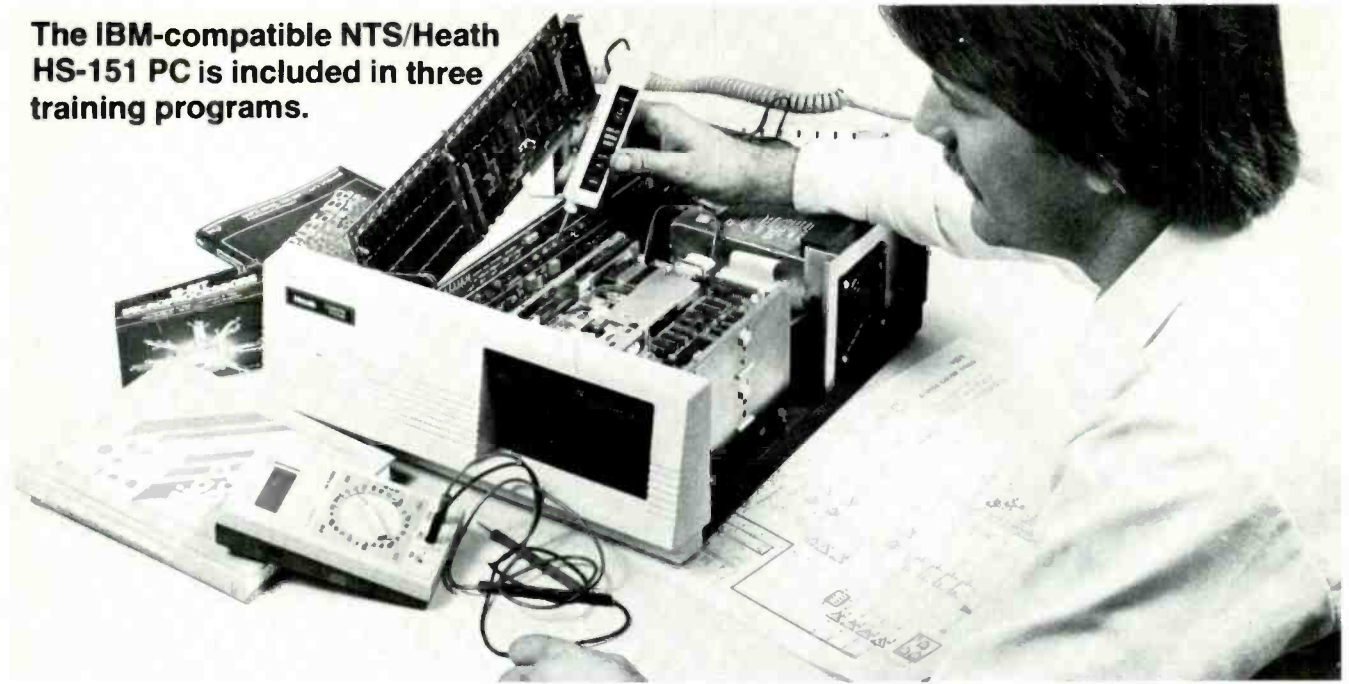

# IF YOU WANT TO GET INTO PC SERVICING YOU HAVE TO GET INTO A MICROCOMPUTER

## Learn PC Servicing By Building Your Own NTS/HEATH HS-151 Desk-Top Computer

NTS Intronic home training gets you right down into the heart of computer circuitry. Learn how microprocessors function, how they operate and are used to solve problems. Your program includes a wide variety of tests and projects you perform as you build your own PC, circuit board by circuit board unit by unit.

## The NTS/HEATH 16-Bit HS-151

This remarkable desk-top PC is the most powerful and versatile ever offered in any home study course. Advanced features include:

- 128 KB RAM user memory, expandable to 640 KB. This power translates into high speed operation,

IBM is a Registered Trademark of International Business Machines Corp. MS is a Registered trademark of Microsoft Corp.

- Two video outputs provide connections for either a color or monochrome video display monitor.
- 16-Bit 8088 microprocessor runs most IBM and MS-DOS software.
- 4 open slots provide for expansion, will accept most peripheral boards designed for IBM PC.

Your NTS training course will teach you how to program on this powerful PC using lessons, texts and diagrams showing you how to make full use of its remarkable capabilities.



## NTS Offers Many Additional Courses in Electronics, and other fields:

**Robotics:** Build the NTS/Heath Hero 1 Robot as you learn robotic programming.

**Video Technology:** Build the NTS/Heath System 3 advanced Color TV as you learn circuit diagnostics.

**TV and Radio Servicing:** A specialized course featuring training in both analog and digital test equipment. Learn servicing of monochrome and color TV receivers.

NTS also offers courses in Auto Mechanics, Air Conditioning/Solar Heating, Home Appliances.

If card is missing, write direct to the address below and specify the course in which you are interested. A FREE color catalog will be sent to you by return mail.

**NTS NATIONAL TECHNICAL SCHOOLS**

TECHNICAL TRADE TRAINING SINCE 1905  
Resident and Home-Study Schools

4000 So. Figueroa St., Los Angeles, CA 90037

# Updating the EXPERIMENTER'S SHOP

Today's budget test equipment and tools make your hobby fruitful!

By Herb Friedman

IF YOU'VE BEEN KEEPING YOUR SHOP UP TO DATE WITH modern technology, it's more than likely you've been out shopping for new hand tools and test equipment. Those purchases are necessary to bring your shop into the digital era, to what some are calling the *age of computers*. And if you're like most experimenters, you probably thought you were having a nightmare when you read the price tags. The cost of both hand tools and test equipment now represents a substantial investment rather than pocket change or a few hours of overtime or a part-time job.

When this writer was starting out in hobby electronics, I purchased my test-bench tools and accessories as the urge struck. If I saw a particularly intriguing tool or gadget, I would generally buy it for pocket change, or a dollar or two—at most, three dollars. Same thing occurred with test gear. If it struck my fancy, I could usually buy it then and there! And if the equipment I wanted couldn't be squeezed into the budget, I could generally buy it *used* at an electronics flea market for a fraction of its cost.

Fortunately, upgrades to electronic circuits and hardware were few and far between, so the same test gear and tools could be used year after year.

Unfortunately, that is no longer true, because the tolerances of the modern sophisticated solid-state circuit is often several magnitudes greater than that of older test equipment: the coarse tolerances of the older test gear can often conceal a defect in modern equipment.

Also, modern circuit components are smaller, more delicate, and highly sensitive to static-voltage damage. A large tool can easily crush several perfectly good components; an oversize test probe can overlap solder contacts and zap a handful of integrated circuits, before you even know that you've done something wrong—and walking across a carpet just before you touch certain components can instantly destroy them.

As a general rule, modern circuits require both new tools and test equipment. While the cost of both are often astronomical—thereby foreclosing the casual or impulse pur-

## ANALOG MULTIMETERS

The famous Simpson 260-5—\$65.00

Radio Shack Multimeter 22-212—\$10.94



CIRCLE 957 ON FREE INFORMATION CARD



CIRCLE 955 ON FREE INFORMATION CARD

Radio Shack Multimeter 22-201—\$19.95

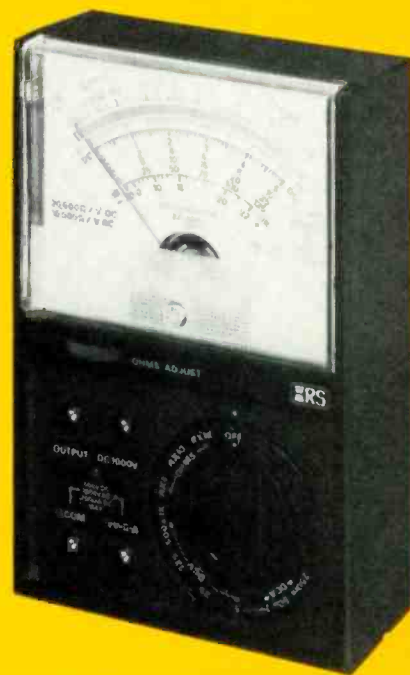

CIRCLE 957 ON FREE INFORMATION CARD

## DIGITAL MULTIMETERS

VIZ DMM WD-785—\$99.00



CIRCLE 954 ON FREE INFORMATION CARD

B&K-Precision DMM 2806—\$75.00



CIRCLE 953 ON FREE INFORMATION CARD

Radio Shack 22-189—\$49.95



CIRCLE 957 ON FREE INFORMATION CARD

chase—it's still possible to equip the shop for modern technology without having to take out a second mortgage on the farm.

### Analog

Even though the world is fast becoming all digital, there's still need for the old-fashioned analog VOM (the Volt-Ohm-Milliammeter)—the kind whose reading is displayed on a meter having several range scales.

Why buy an analog meter when, dollar-for-dollar, a digital display meter provides greater accuracy and convenience? Because, it's hard to track a varying voltage with a digital meter. The reading of a typical experimenter-quality digital meter is upgraded every 1.5 to 2.5 seconds. A transient circuit disturbance that self-clears almost the instant it occurs will rarely be displayed by a digital meter. However sophisticated the test-bench setup, you'll need an analog VOM when you have to track a varying value.

While the legendary Simpson 260 VOM is still available, the various models are priced from \$100 up. That is often not only beyond the budget of most experimenters—the VOM's performance is well beyond what's needed. If you have no need for the high-performance features of a Simpson 260, or its equivalent, you're probably better off opting for a digital meter and a very low-cost VOM for those times you'll need to track a varying value.

Low-cost VOM's start out at \$8, the price rising very slowly as features are added. All models will measure voltage with an acceptable degree of accuracy and convenience for *brute-force* tests, such as checking the voltage of a car battery, the powerline, or the output of a battery eliminator. Resistance measurements are what create problems for the lowest priced VOM's. They generally have only one resis-

tance range, which jams low and high values into a teeny area at the ends of the scale. Accurate, or even useful readings, are possible over a somewhat limited range of resistance. About \$15 or \$20 will buy a VOM with several resistance ranges, providing a finer resolution of low and high resistance values.

Also, there's the question of *meter loading*. Except for the current measurements, VOM's represent a resistance connected in parallel with the circuit being tested. The least expensive VOM's generally represent 1000-ohms-per-volt sensitivity for the total range. If your meter is set for a full-scale range of 5 volts, the meter represents a resistance of  $5 \times 1000$  or 5000 ohms. If the full-scale range is 15 volts, the meter represents a load of 15,000 ohms.

Obviously, if you're trying to read the collector-to-ground voltage of a transistor with a 10,000-ohm collector-load re-

The VIZ bench-top/carry digital multimeter WD-763 is an auto ranging device that sells for \$249.00.

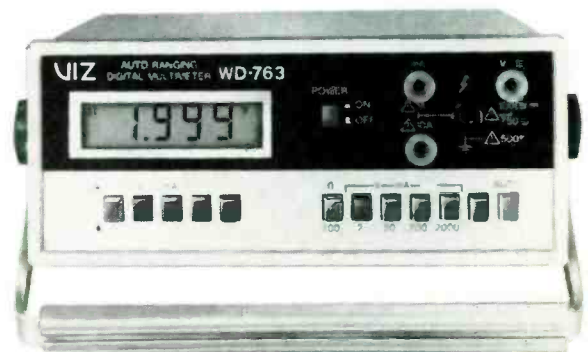

CIRCLE 954 ON FREE INFORMATION CARD

## SPECIALIZED BUDGET TEST EQUIPMENT



Radio Shack  
Dynamic Transistor Checker  
Model 22-025—\$14.95

CIRCLE 957 ON FREE INFORMATION CARD

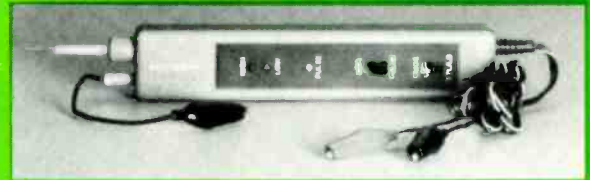

Radio Shack Digital Logic Probe 22-302  
with simultaneous tone—\$19.95

CIRCLE 957 ON FREE INFORMATION CARD

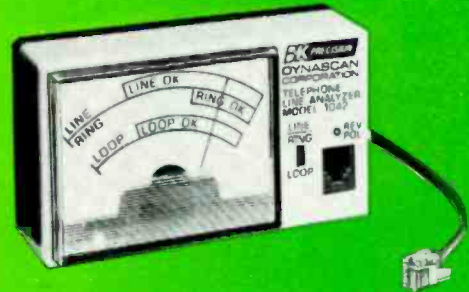

B&K-Precision Model 1042 analog  
telephone line analyzer—\$19.95

CIRCLE 953 ON FREE INFORMATION CARD

sistor, the 15,000-ohm load of the VOM is going to affect the circuit's operation, because it will appear in parallel with the 10,000-ohm circuit resistance.

About \$20 to \$30 will buy a meter rated anywhere from 20,000- to 50,000-ohms-per-volt sensitivity. If your test gear will be limited initially to only a VOM, it's probably better to trade-off features for a higher ohms-per-volt rating. Even the most sophisticated meter isn't too valuable if it seriously disturbs the circuit being tested.

Normally, when someone will be working with circuits that will be unusually sensitive to circuit loading, a special kind of analog meter called an FET solid-state VOM is recommended. The input to those meters is a field-effect transistor, which provides a load impedance of approximately 10 Megohms—which won't have any effect on the average experimenter circuit or project. Unfortunately, those meters

are rather expensive. The least expensive falls into the range of \$150 to more than \$350. On the other hand, a DMM—a digital multi-meter—with the same input impedance sells for well under \$100. Other DMM's are closer to \$50. For many experimenters, and even service technicians, the DMM will be the better buy, even with its lack of ability to track continuously varying values.

Most DMM's work extremely well, regardless of price. As a general rule: If you're on a tight budget, don't buy the best meter hoping to save up for the other items you'll need. That idea rarely works out well. Instead, purchase the least expensive DMM, because, more often than not, all you will sacrifice is an accuracy that you probably won't need and possibly better overall construction. But if you give a DMM the same care you would an ordinary analog VOM, it will probably last one day short of forever.

### Logic Probes

Next item on your list should be a *logic probe*. Digital circuits, from your home computer to the rare-roast-beef selector on the microwave oven, work by digital pulses rather than voltage levels. The pulse is over and gone before your meter—even a digital meter—gets a chance to respond. Logic probes stretch the displayed pulse so that an indicator—usually an LED—stays on long enough to be observed. Depending on the particular probe model, the LED might indicate single pulses or pulse trains, or lock on until manually released. Naturally, the more features, the higher the price—which starts at about \$20 and goes up, depending on features and the frequency rating. That's an indication of how fast a pulse it can freeze.

### Batteries Low?

To get away from high-tech for a moment, the lowly battery checker that sells for about \$10 should have a prominent place

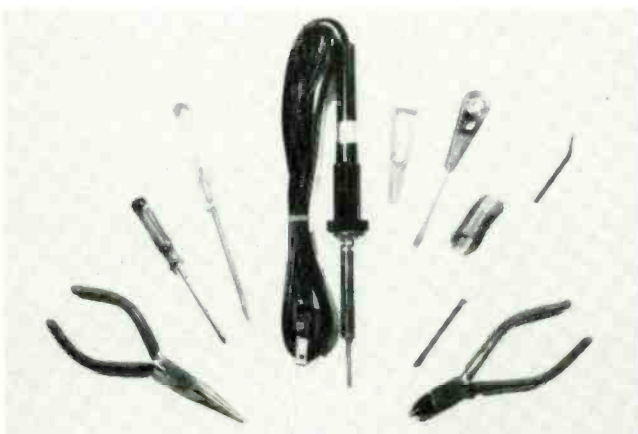

Science Fair 10-piece electronics tool set (64-2801) is  
a starter's set that sells for \$14.95.

CIRCLE 957 ON FREE INFORMATION CARD

on any experimenter's test bench. Much equipment—from home-brewed projects to a portable DMM—is powered by batteries, and many of such equipment don't have a low-battery indicator. Many are the hours spent troubleshooting a project or a perfectly good piece of equipment whose only problem is weak batteries. The first thing to check when anything goes wrong with battery-powered equipment are the batteries. Use one of the multi-volt, multi-load meters which allow you to switch-select a light, medium, or heavy current drain. Don't try to check batteries with your VOM or DMM because a battery will always indicate the proper voltage when it's unloaded (not supplying current).

### Pictures Tell The Story

Every electronics teacher worth his paycheck always tells his class that if stuck on a desert island the one piece of test equipment he'd want is an oscilloscope, because it not only measures voltage but tells you what it looks like. If you're into audio, RF (low-band), even digital, a scope shows precisely what the signal waveform looks like.

Back in the the early days of electronics, any general-purpose scope was all the average hobbyist needed. Today, a general purpose scope is almost useless. For digital work the scope must be triggered; for just about anything it needs a frequency response to at least 20 MHz. And for *serious* work, the scope should have a delayed sweep, possibly dual trace, and a calibrated time base. The price of such a scope is about \$500-\$900—not inexpensive by any means. The general rule here is if you can't afford at least that minimal performance and features don't buy anything! Wait until you can afford a decent scope. While you might get by with a what is called a TV service scope, for digital and RF work you'll need the features of the laboratory-type scope. It's best to wait until you can afford what's really needed. Of course, if your main interest is TV, get a TV scope. Their convenience of switch-selected H and V sweeps is a big advantage for TV work.

### 1...2...3...

A digital frequency counter should be on every experimenter's wish list. Other than the megabuck laboratory signal generators, few are accurate enough for modern circuits, whether it be an audio null filter to squash hum when dubbing a friend's tape, or an RF-notch filter to keep the broadcast station down the block from swamping an FM receiver. But almost any signal source, no matter how inexpensive, can be accurately set to the desired frequency(s) by checking its output with a frequency counter.

Most hobbyists can get by with a battery-powered portable counter that covers from slightly above DC to about 100 MHz. Low-cost frequency-extender accessories are available for those who need coverage above 100 MHz. Several counters are available for about \$100-\$160 depending on the number of display digits (which determines the resolution) and the operating features.

When it comes to frequency meters and counters, anything is better than nothing. If you can't afford the best, try to get something.

### But It Looks OK.

You can't tell if a transistor is defective just by looking at it, but fortunately most either work or don't work. There is rarely such a thing as a *weak* transistor. While it's advantageous to know the transistor's actual leakage and beta values, in most instances all you really need to know is that

## OSCILLOSCOPES

**Hameg 60-MHz HM605—\$965.00**  
CIRCLE 977 ON FREE INFORMATION CARD

**Iwatsu DC-20-MHz SS-5702—\$535.00**  
CIRCLE 949 ON FREE INFORMATION CARD

**Leader LBO-522 20-MHz—\$470.00**  
CIRCLE 945 ON FREE INFORMATION CARD

the transistor is working. That is, it is neither *burned* or open, and that can be determined by an under-\$20 transistor checker. The instrument won't measure beta, but it will tell you if  
(Continued on page 98)

# Picture Fixer

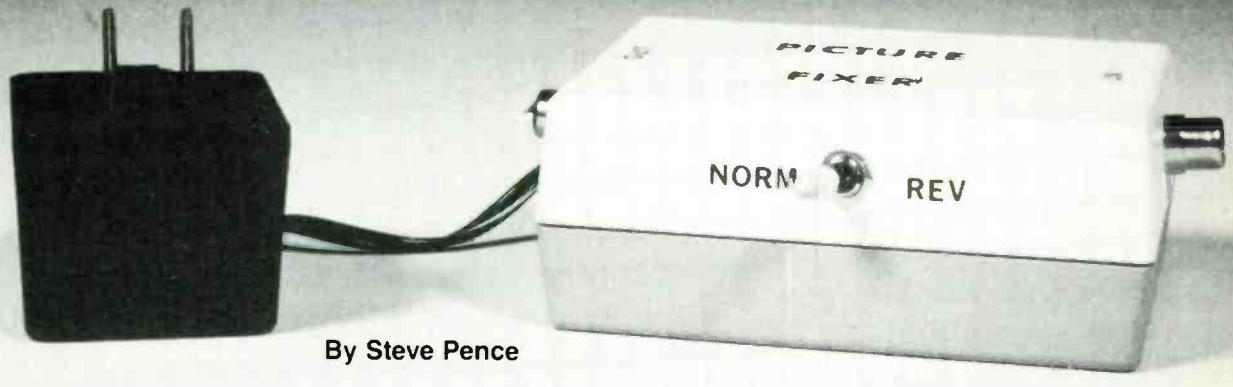

By Steve Pence

□ MOST HOME COMPUTERS HAVE AN RF OUTPUT THAT ALLOWS them to be connected to a standard TV receiver via the antenna terminals. That allows you to use your TV set as a monitor, saving you extra cost. Unfortunately, after the novelty of the new computer wears off (about an hour at our house), the rest of the family wants the TV for something frivolous such as network programming.

Along with an RF output, many computers also have a direct video output designed to drive a standard monitor. So

it's usually not long before you begin looking for just such a monitor.

Most surplus computer monitors will use either a green or amber phosphor for the screen. That is great if your computer's video format provides for bright characters on a dark background. Many computers do not follow that format and you soon find out that no one knows how to correct the situation. The project we're about to describe, solves that problem.

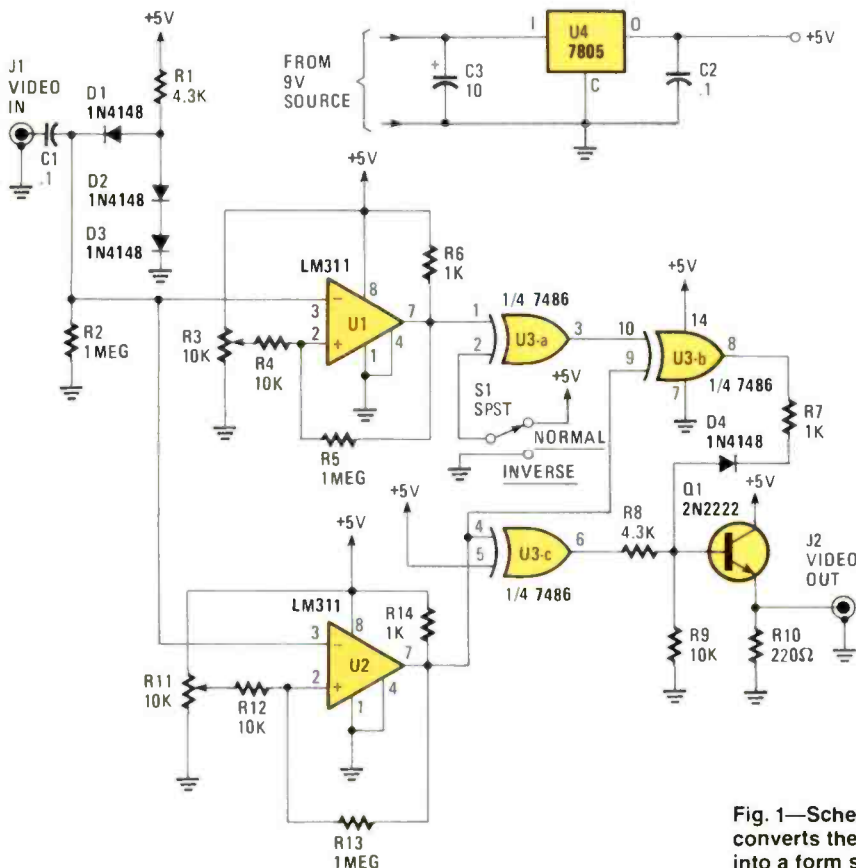

## PARTS LIST FOR PICTURE FIXER

### SEMICONDUCTORS

- D1—D4—1N4148 diode
- Q1—2N2222 NPN transistor
- U1, U2—LM311 comparator integrated circuit
- U3—7486 or 74LS86 EXCLUSIVE-OR integrated circuit
- U4—7805 5-volt regulator integrated circuit

### RESISTORS

- (Fixed resistors are 1/4-watt, 5%, units)
- R1, R8—4300-ohm
- R2, R5, R13—1-Megohm
- R3, R11—10,000-ohm, linear-taper, trimmer potentiometer
- R4, R12, R9—10,000-ohm
- R6, R14, R7—1000-ohm
- R10—220-ohm

### CAPACITORS

- C1, C2—.1- $\mu$ F, polyester, 10%
- C3—10- $\mu$ F, 25-WVDC, tantalum

Fig. 1—Schematic diagram for the Picture Fixer. The circuit converts the output from a color computer such as the T1-99/a into a form suitable for display on a monochrome monitor



## In the upside-down computer world this project flips your video right-side up!

The simple circuit, shown in Fig. 1, that makes up the Picture Fixer will accept the video signal from your computer, separate the sync pulses, invert just the video, add the new video to the old sync pulses, and then send them on to your newly acquired monitor.

### Circuit Description

Refer to the schematic shown in Fig. 1, and the waveform timing-diagram shown in Fig. 2, for the following discussion.

The video signal is brought in through J1 and applied to a clamping circuit consisting of C1, D1, D2, D3, R1, and R2. The clamp circuit forces all of the sync pulses to line themselves up at the same DC voltage level.

With the video voltage clamped, the trip points of the comparators that follow can be set with trimmer resistors R3 and R11, and will not have to be readjusted. One comparator, U1, is adjusted to change states with a change in either video or sync-pulse levels. The other comparator, U2, is adjusted to trip on changes of sync-pulse levels only.

The output of U1 now consists of a logic level (0 to +5 volts) signal that contains both sync pulses and video. The composite signal is coupled to an EXCLUSIVE-OR gate, U3-a, where it is either inverted or not inverted, depending upon the position of switch NORM/REV S1. The output, at pin 3 of U3-a, is next sent to U3-b. There the composite signal is combined with the *sync-pulse only* signal from U2. The EX-

CLUSIVE-OR action of U3-b cancels out the sync pulses leaving only video at its output.

Since the sync pulses are inverted as they pass through U2, they must be inverted once more before being combined with the video signal. That final inversion is performed by U3-c, and that device's output is combined with that of U3-b via D4, R7, R8, and R9. The newly combined signal is buffered by emitter-follower Q1 and sent to the outside world via J2.

The circuit can be powered by a 9- to 12-volt wall-mount power supply. The supply voltage is regulated down to five volts by U4.

### Construction

Although a printed-circuit board makes assembly much more convenient it is not a necessity. The project can be built on perfboard using wire wrap since layout and wiring are not critical. If you wish to use a printed-circuit board, an appropriate foil pattern is shown in Fig. 3; the corresponding parts-placement diagram is shown in Fig. 4.

Regardless of the construction technique you use, here is a pointer to keep in mind: Trimmer resistors R3 and R11 should

### ADDITIONAL PARTS & MATERIALS

S1—SPST, miniature toggle  
J1, J2—Phono jack  
Wall plug transformer (Radio Shack 273-1455 or equivalent), printed-circuit board, enclosure (Unibox #120 or equivalent), etc.

The following are available from Elephant Electronics Inc., P.O. Box 41770-P, Phoenix, AZ 85080: PF-1B—Printed-circuit board, \$6.55 each; PF-1—complete kit of all parts listed above, \$19.95; PF-1A—assembled and tested unit, \$29.95. Arizona residents add 6% sales tax. Please add \$2.50 per kit for first class postage and handling in the U.S., Canada, and Mexico. Other foreign orders add \$6.00 for shipping and handling, and remit payment via a cashier's check or international money order drawn on a U.S. bank. All orders allow 4 to 6 weeks for delivery.

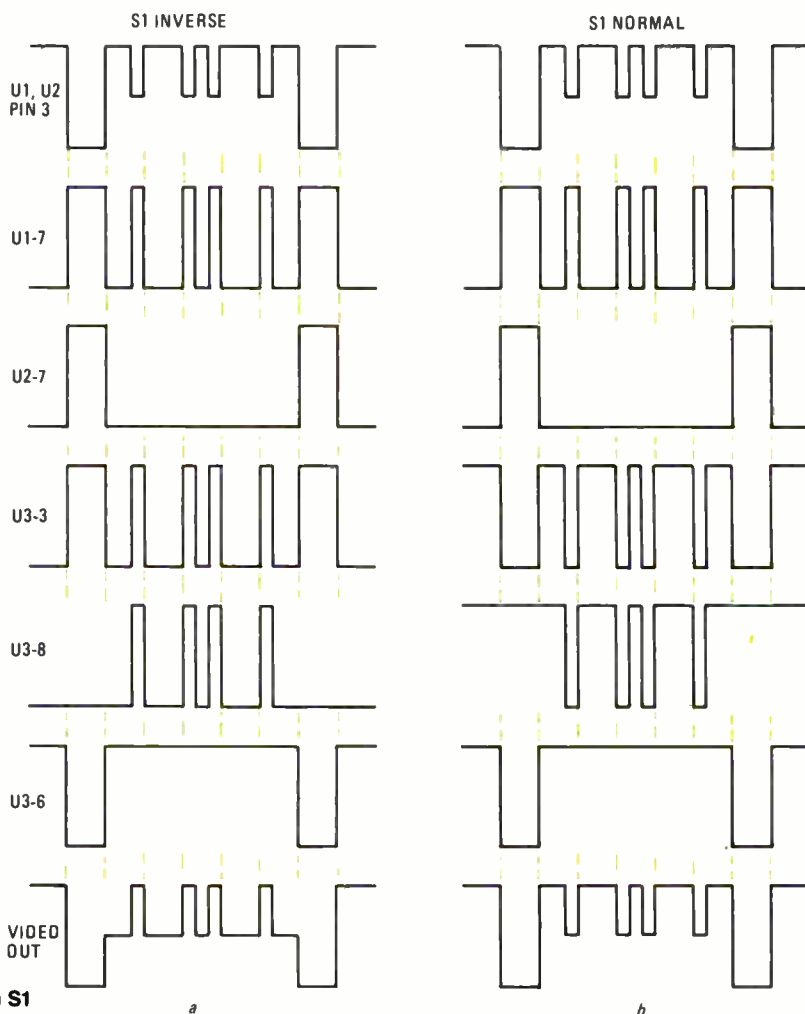

Fig. 2—Timing diagram for the Picture Fixer. When S1 is set to INVERSE, the diagrams shown in A apply; when it is set to NORMAL, the diagrams shown in apply.

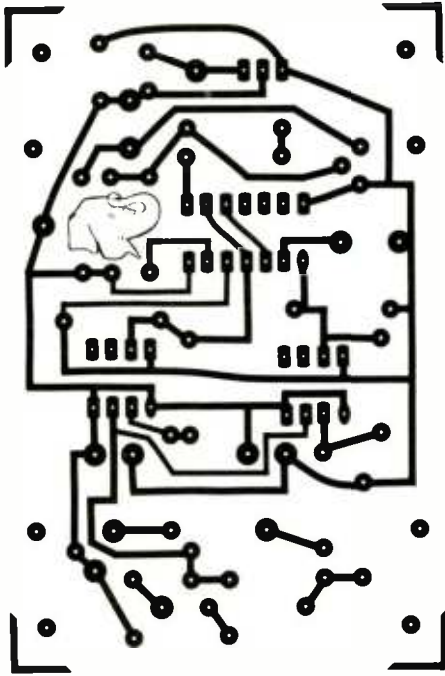
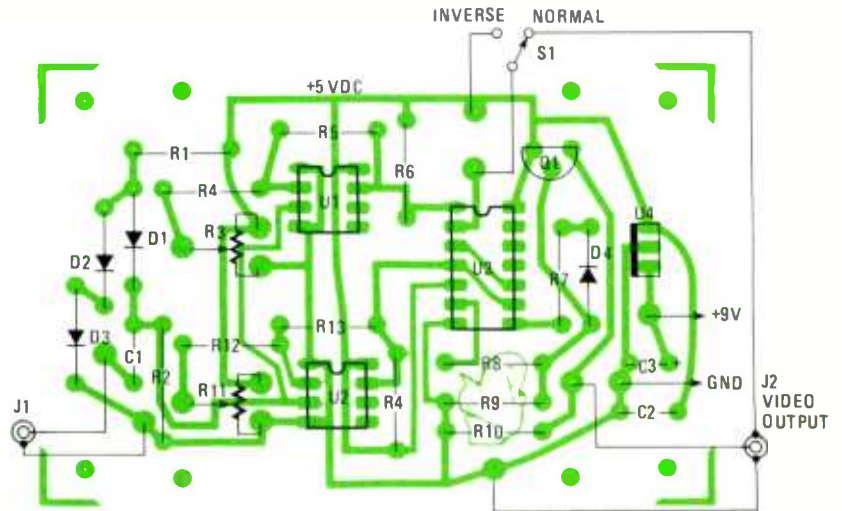

Fig. 3—Although any construction technique can be used, mounting the components on a printed-circuit board is recommended. An appropriate full-size foil pattern for such a printed-circuit board is provided here.

Fig. 4—Parts-placement diagram for the printed-circuit board that is shown in Fig. 3. Note that the board is *flopped* and shown in an x-ray view with external connections indicated.



be the horizontal-mounting type to make adjustment from above easy to do.

If the power supply module you use provides more than nine volts, you will need to add a heat sink to U4. A few square inches of aluminum or brass sheet will be sufficient.

### Checkout

The easiest method of checkout is simply to connect the unit to your monitor and computer. Begin with both potentiometers R3 and R11 set completely counter clockwise. Type a few lines of text into your computer's keyboard and observe the video image.

Now adjust R11 slowly clockwise while watching your monitor. At some point the screen will jump or change brightness slightly. Stop and slowly adjust R3 clockwise until the text you typed appears on the screen. Fine-adjust both R3 and R11 to suit your own taste.

### Final Comments

The Picture Fixer will work with any computer that can provide a signal level of a half a volt peak-to-peak, or more. If you own a TI-99, this project is a perfect match.

If your computer is not equipped with a direct video output jacks, you can usually tap off a usable video signal at the input to the computer's RF modulator.

Keep in mind that this is a digital circuit designed to be used with computer-generated video. If you attempt to use it with video from a camera or VCR the results will not be satisfactory.

The reason is that the Picture Fixer unit responds only to logic levels (black-and-white, on-and-off, etc.) and not the voltage levels needed to represent shades of gray. In addition it will not pass color signals. If you run the output of your color computer through it the signal will be converted to black and white. ■

The completed project is shown here mounted in the enclosure mentioned in the Parts List. Note that U4, the 5-volt regulator, is heat sunked as described in the text.

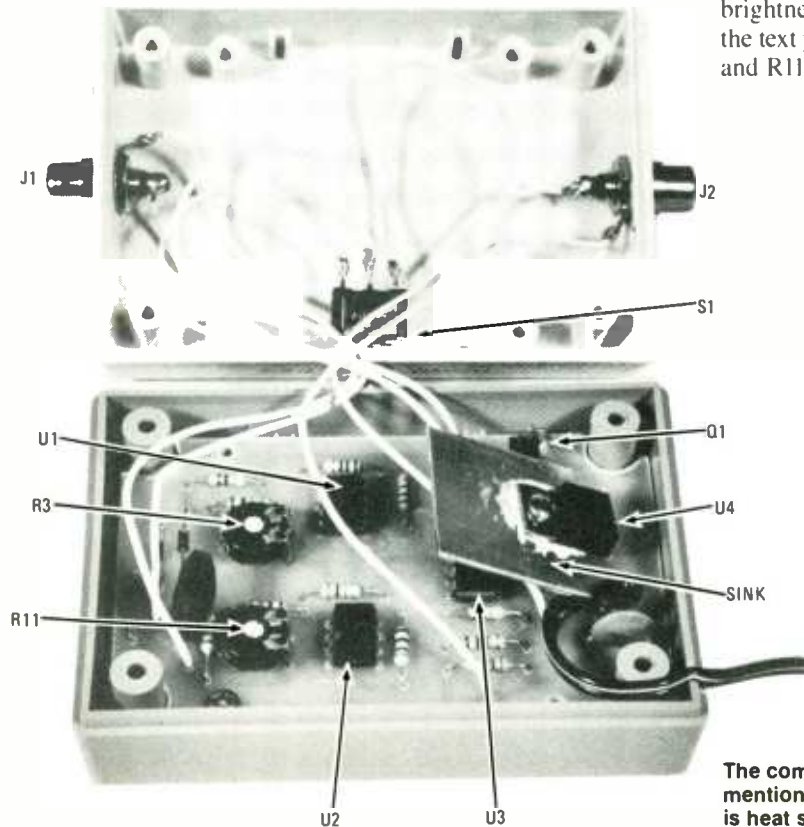



# HANDS-FREE TELEPHONE

**Now you can write, type, or input-data when talking on the telephone!**

□HOW MANY TIMES HAVE YOU BEEN USING THE TELEPHONE and tried to write notes, or enter data into your computer, while holding a clumsy telephone handset tucked under your chin? How many times have you been put on hold and wished you had your hands free to do some pressing bit of paper work?

After that happened to you, you probably wished you had a light-weight telephone headset so you could have a hands-free telephone. If you are like many people, you were very surprised at the exorbitant price you found you would have to pay—anywhere from \$70, \$100, up to \$170—for such a simple gadget as a headset. You asked yourself, why should a telephone headset cost that much when a cassette player with stereo headphones costs \$29.95 and a cassette recorder with all its complexity and mechanisms costs only \$22.95? Why hasn't someone put the two together, throwing away more than half of each, and still produce a high-quality headset? No one has, but you can!

This article will show you how to build a telephone accessory that will give you hands-free operation for under \$29.00. That sounds incredible, but it's true. You may be able to save even more, because everything in the telephone-adaptor's design and construction relies on parts that you may already have, or on old projects that are readily available.

## Using the telephone adapter

The name of the device is Hands-free Telephone Adapter, but we will call it the telephone adaptor, or adaptor, in the text. The adaptor replaces the telephone handset of your telephone. Set the adaptor down on the work surface in front

of you, or beside the phone. Disconnect the curly cord from the handset of your telephone and connect it to the adaptor. Plug the stereo earphones in to the adaptor and only use the disconnected handset to operate the telephone-hook switch. If you have a several extensions coming into the telephone, you could use the pushbutton to hang-up or pick-up.

As you use the telephone adapter, you will note several striking differences between its performance the the performance of your normal telephone. The adapter's microphone is very sensitive and will pick up your voice even if you're across the room. Your voice will sound very clear to the person at the other end of the line, since your speech will not have the severe harmonic distortion generated by a telephone's carbon microphone. Besides, a very real advantage of having sound in both of your ears from an earphone set is that the earphones give you very clear sound. You will be able to understand long-distance telephone calls even when the trunk-line connection is poor and noisy.

After actually using the telephone adapter and the light-weight headphones, and after becoming accustomed to the advantages of hands-free telephone operation, you will find it irksome to return to the burden of the poor-quality, old-fashioned handset.

## Earphone and microphone

If the telephone adapter is to replace the handset properly, the impedances and signal levels of the handset must be maintained. The telephone's earphone has a permanent magnet and voice coil which, produce sound very efficiently. Less than 30 millivolts peak-to-peak across its terminals will gen-

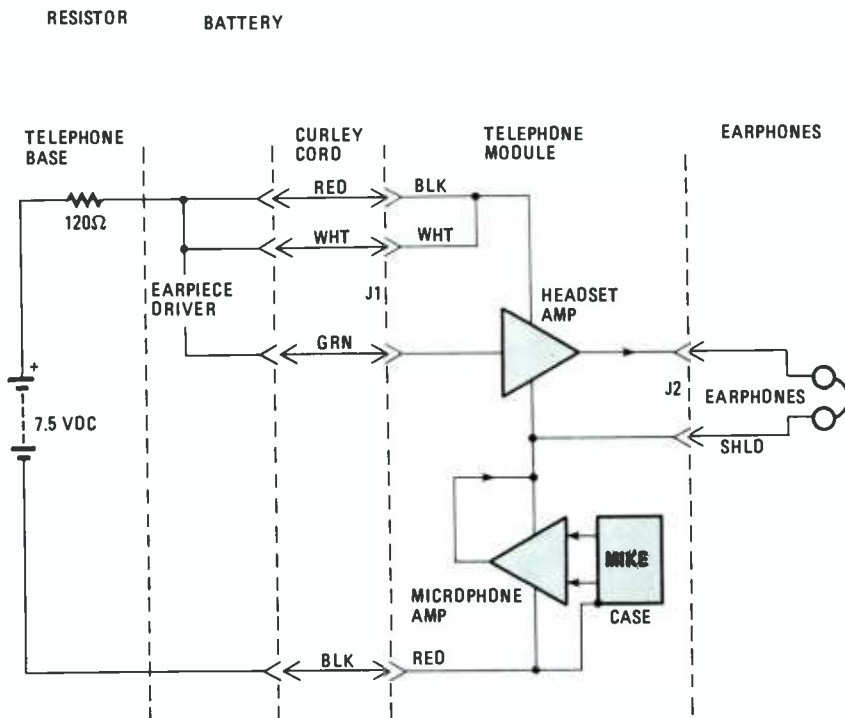

Fig. 1—Simplified block diagram of the Hands-free Telephone Adaptor illustrates the basic circuit operation and the detailed interconnection of the device to your home's telephone line.

erate adequate sound. The earphone's ability to efficiently generate sound also makes the task of accurately characterizing its electrical impedance with a simple network of passive components practically impossible. However, over the audio spectrum its impedance is partially inductive and partially resistive with a magnitude of about 100 ohms.

Since the earphone is supplied with so little energy from the telephone base, it is reasonable to assume that the telephone's operation would not be adversely affected if the replacing circuit's impedance does not exactly match the earphone's impedance. Just an amplifier with sufficient gain and an input impedance around 100 ohms is needed to replace the earphone.

Another characteristic of the earphone is that it may be used as an active microphone. When the earphone is spoken into, the resulting movement of the voice coil in the permanent magnet will generate a signal of about twenty millivolts peak-to-peak.

The telephone's microphone is a passive microphone and supplies no energy. It is a two-terminal, variable resistor which has a quiescent impedance anywhere from 100 to 300 ohms; speech modulates that impedance about twenty to thirty percent.

The microphone's resistive element is comprised of loose carbon granules sealed between two contacts. A diaphragm transfers the air-pressure variations of the sound waves to pressure variations on the granules. As the pressure varies on the granules, the resistance across the terminals of the microphone varies.

Unfortunately, those pressure variations do not produce linear changes in resistance. As the microphone is used, its resistance *increases* from granules losing contact with each other more than its resistance *decreases* from granules being compressed—significantly distorting the signal. Fortunately, that speech distortion is barely noticeable. After years of telephone useage, speech distortion is considered the norm.

In order for the variations of the carbon microphone's resistance to generate any usable signals, the telephone line

(through the telephone base) has to supply the microphone power, in the form of current, for it to modulate the DC current. When a telephone is connected to an active phone line and goes off-hook, the terminals to which the microphone is connected act as if the microphone had been connected to a 7-volt battery with about 120 ohms in series with it. The microphone will have a voltage drop of about four to five volts across it and will have about 20 to 30 milliamperes of current to modulate. Speaking into the microphone will then generate a voltage variation of about 1 volt peak-to-peak across the microphone. It is that signal that is sent down the phone lines.

### Theory of operation

To understand how the circuits in the telephone adaptor work, keep in mind that the telephone adaptor replaces the telephone handset. It has to pick up sound and put it into the phone line, and it has to get signals from the phone line and generate sound for you. It must do all that without too much of the one interfering with the other. Luckily the two functions, send and receive, are already separated by the telephone base. The two electrical signals do, however, have a common connection inside the telephone base but travel separately to the handset over the two pairs of wires in the curly cord. The circuits in the telephone adaptor take advantage of both the common reference connection and the separation of signals. The signal that would have normally gone to the earpiece goes to a transistor amplifier to drive a set of stereo headphones. The signal that would have come from a carbon mike now comes from a transistor amplifier and an electret microphone. Both amplifiers are powered from the phone line via the curly cord and do not require any external power.

When the telephone is connected properly to the phone line, the common connection between the earphone and the microphone is the plus lead of the power going to the carbon microphone. That relationship can be seen in Fig. 1, along with the equivalent circuit for the telephone and the block

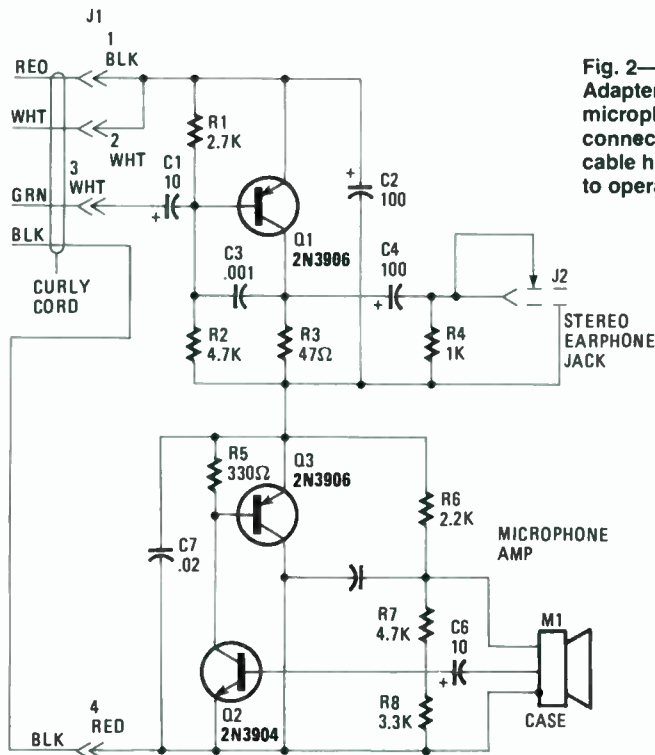

Fig. 2—The schematic diagram of the Hands-free Telephone Adapter is drawn so that the two distinct headset and microphone amplifier sections can be seen quickly. For connecting the device to the telephone system refer to the cable hookup in Fig. 1. Jack J2, a stereo mini-jack is wired to operate the stereo earphones as a monophonic device.

diagram of the two amplifier circuits in the telephone adapter. Figure 1 shows how the headset amplifier's input signal is referenced to its plus *power* lead and its output signal is referenced to its minus *power* lead. The power terminals of the headset amplifier must be an AC short, so that no signal that is generated by the microphone amplifier will appear across them.

The electret microphone is a powered microphone with a built-in FET integrated-circuit (IC) amplifier to provide a lower output impedance than the electret would have provided by itself. The output signal from the FET IC amplifier is referenced to the electret's most negative terminal—

which, in that case, is also the microphone amplifier's minus power terminal. The microphone amplifier's output signal is a modulation of the current supplied to it by the telephone base. That modulation of current duplicates the function of the carbon microphone it replaced.

In the schematic diagram for the Hands-free Telephone Adapter shown in Fig. 2, transistor Q1 of the headset amplifier circuit amplifies the 30-millivolt signal (that would have gone to the earphone) to .5 volts, which sufficiently drives the stereo earphones. Since Q1 has about 25 milliamperes of bias current, it has an input impedance of about 100 ohms. As stated earlier, an impedance of 100 ohms closely approximates the impedance of the telephone earphone it replaced.

Capacitor C1 blocks any DC current from shorting back into the telephone base. Capacitor C2 provides the very important AC signal short around the amplifier. Capacitor C3 provides high-frequency rolloff characteristics and prevents the amplifier from oscillating. Capacitor C4 is a DC block to the 35-ohms impedance of the stereo earphones, and resistor R4 bleeds off any charge build up to prevent a *popping* sound when the stereo earphones are plugged into the mini-earphone jack J2. The headset amplifier has only about 2-volts DC across it.

### Microphone amplifier

The microphone amplifier circuit has about 3-volts DC across it. It amplifies the 20-millivolt signal from the electret

## PARTS LIST FOR HANDS-FREE TELEPHONE ADAPTER

### SEMICONDUCTORS

- Q1, Q3—2N3906 PNP transistor
- Q2—2N3904 NPN transistor

### RESISTORS

- (All resistors are fixed units, 1/4-watt, 5% tolerance)
- R1—2700-ohm
- R2, R7—4700-ohm
- R3—47-ohm
- R4—1000-ohm
- R5—330-ohm
- R6—2200-ohm
- R8—3300-ohm

### CAPACITORS

- C1, C6—10- $\mu$ F, 20-WVDC, electrolytic
- C2, C4, C5—100- $\mu$ F, 20-WVDC, electrolytic
- C3—.001- $\mu$ F, ceramic disc or mica
- C7—.02- $\mu$ F, ceramic disc

### ADDITIONAL PARTS AND MATERIALS

- J1—Base jack for handset cord (Centel #06-4438, or

- Radio Shack equivalent)
- J2—Mini-stereo jack, PC mount
- M1—Microphone, electret condenser (Primo, Co., 2468 Delta Lane, Elk Grove, IL)
- 1—Stereo earphones with cable and mini-stereo plug to match J2
- Deluxe metal utility cabinet (Radio Shack 270-251), .5-in. rubber grommet, hardware, printed-circuit board materials, wire, solder, etc.

As a courtesy to readers, a complete kit of parts is obtainable from the authors. The kit contains stereo earphones, an unmodified metal box, a vector board, both connectors, electronics parts, and miscellaneous mounting hardware. The kit can be ordered for \$29.95 plus 6½% sales tax in California and \$4.00 for shipping and handling. The microphone, by itself, is available for \$3.50. Make check payable to AJM and mail to: AJM, 619 North First Street, San Jose, CA 95112. Sorry, no COD's.

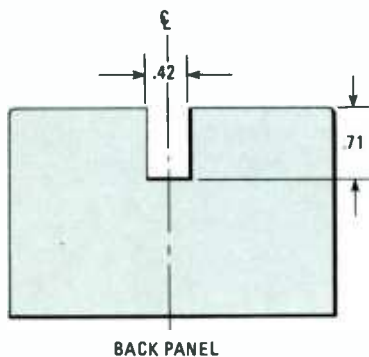

BACK PANEL

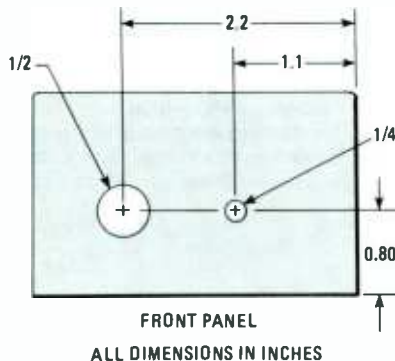

FRONT PANEL

ALL DIMENSIONS IN INCHES

Fig. 3—The front template is important to the builder because it permits the printed-circuit board to align properly with the front panel. The rear template is scaled to match the telephone connector (J1) specified in the parts list. Should you use a different one, do not cut the rear panel until you have measured the new connector.

microphone to about 2 volts peak-to-peak. The total DC voltage across both amplifier circuits is 5 volts. The 2 volts peak-to-peak appears at 5-volts DC, since the headset amplifier is an AC short. That 2-volt peak-to-peak signal at 5-volt DC duplicates the signal levels of the carbon microphone, which the circuits replaced.

The microphone amplifier circuit is composed of transistors Q2 and Q3 in an inverted Darlington configuration. Another, and perhaps easier, way to understand the operation of that circuit is to consider Q3 as an emitter-follower stage.

The electret microphone has a built-in FET IC amplifier that needs at least 3 volts at 0.4 milliamperes of clean supply power in order to provide an output impedance of 200 to 800 ohms. Resistors R6 and C5 provide that clean DC power to the FET IC and also provide the bias to Q2 without any AC feedback, which would have reduced Q2's gain. Capacitor C6 blocks the output DC bias from the FET IC.

A momentary pushbutton switch can be added to provide muting capability to the adapter. That is similar to putting a call on hold. The switch should be placed between C6 and the junction of R7 and R8. A 50,000-ohm resistor should be placed in parallel with the switch terminals to maintain the charge on C6, so there is no *popping* as the momentary switch is pressed and released.

## Construction

It should not take longer than four hours to build and check out the telephone adapter once you have assembled all the parts and necessary tools.

First start by modifying the box. Only the bottom half of the box is modified. After removing the four rubber feet, drill out their mounting holes with an 1/8-inch bit. In the center of the back wall of the box, cut a slot for the curly cord connector 0.71-inches high and .42 inches wide. The material is thin aluminum, so a nibbler tool will work well.

On the front wall of the box, drill a .5-inch hole for the electret microphone grommet .80-inch up from the flat bottom surface of the box and 2.20-inch over from the right edge of the front of the box. Also, drill a 1/4 inch hole for the stereo earphone jack 0.80-inch up and 1.10-inch from the right. To make that task easier, use the templates shown in Fig. 3.

Now mount the rubber feet by using the one-inch long 6-32 screws. Use the washers that were already with the feet and tighten them down with the hex nuts. The final order of the parts that are placed along those screws will be: washer, rubber foot, metal box, nut space, printed-circuit board, and nut. If you do not use spacers, the order will be: washer, rubber foot, metal box, nut, nut, printed-circuit board, and nut.

Slide the curly-cord connector into the slot to check for possible interference. It may be necessary to remove a small amount of plastic from the connector in order for it to slide all the way down into the slot. The connector should not be left in the slot at this time. Insert the .5-inch rubber grommet for the microphone into the hole in the front wall. Do not mount the jack for the stereo earphones at this time. The jack is printed-circuit-board mounted and will slide in with the whole assembly later.

Here's the Hands-free Telephone Adapter ready to go. Note that the curly cable is not connected to the handset on the phone. The handset is used solely as a weight to hook-down the telephone when not in user. Should you have trouble with the telephone, remove the curly cord from the adapter and reconnect it to the telephone. If the problem is still there, return the 'phone to the local telephone office for repair.



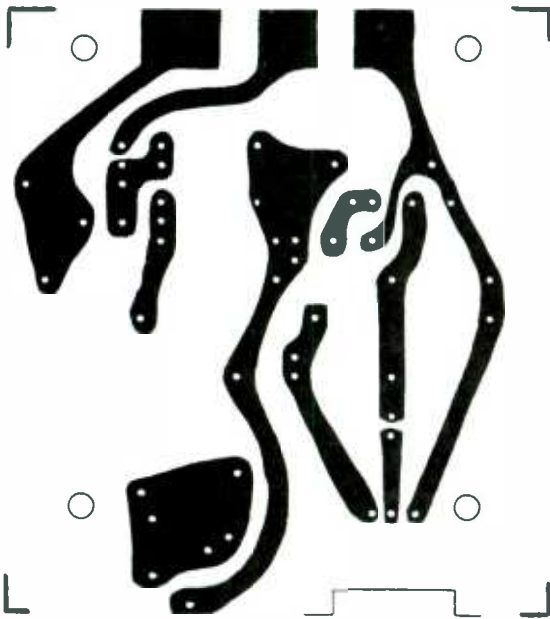

Fig. 4—Same-size foil pattern that can be used to make a printed-circuit board for your home-brew project. Should you use a Vector board with a hole-grid pattern spaced .1-inch apart, lay this diagram on it and insert the flea clips in position from the bottom of the pre-drilled board.

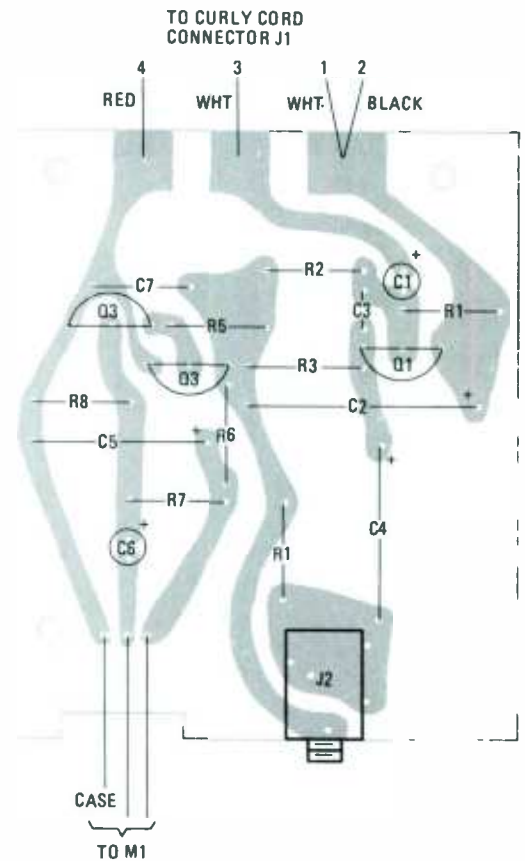

Fig. 5—The parts for the project are shown here positioned on a drawing of an x-ray view of the printed-circuit board.

### The circuit board

The circuit board for the telephone adapter can be made one of two ways. It can be a printed-circuit board made as a single-sided copper-foil board using the pattern in Fig. 4. Or, because the adapter has so few components with a simple layout, the components can be mounted onto a piece of vector board. Use a piece of predrilled vector board which has .1 inch centered holes, cut it to the dimensions in Fig. 4, and drill it in four places for the mounting screws.

Assemble the board, soldering in all the components except the microphone and the phone connector. See Fig. 5. The microphone will be soldered in as the whole adapter is assembled and the phone connector will be soldered in during an electrical check-out. If vector board is used, assemble the components by bending their leads on the reverse side of the board to make most of the connections. Refer to the schematic diagram (Fig. 2) and the pattern of Fig. 5 to make the connections. Only a few connections will require extra pieces of connector wire. Again, do not solder in the microphone and the phone connector at this time.

Modular phones in the United States should be wired and connected the same. To verify the connections of your telephone, use the adapter's phone connector and a VOM. Disconnect your telephone from the phone line, disconnect the handset from the curly cord, and plug the curly cord into the telephone adapter's phone connector. With the handset *off-hook* you should read about seven ohms impedance between the black lead and the white lead that is directly adjacent to it (line 1 and 2 in Fig. 6.) Those two leads have a common connection inside the telephone. Twist those two leads to-

gether, because they will be soldered together in the adapter. The impedance between the black lead and the other white lead should read about 100 ohms.

Place the disconnected handset *on-hook*, reconnect the telephone base to the telephone line, and lift the handset *off-hook* again. There should now be a voltage of about 7.5-volt DC between the black lead and the red lead. The red lead should be negative with respect to the black lead. That is very

*(Continued on page 96)*

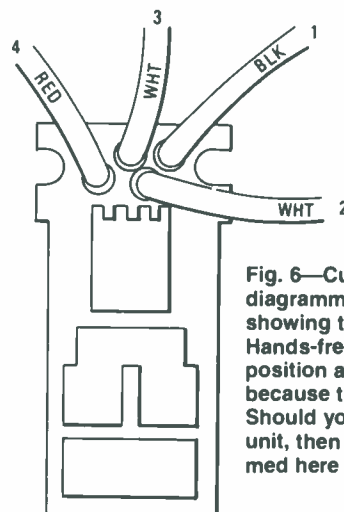

Fig. 6—Curly-cord connector J1 is diagrammed here from the rear showing the wires connected to the Hands-free Telephone Adapter. The position and numbers are important because two of the wires are white. Should you obtain a non-standard unit, then number the wires as diagrammed here and ignore the colors.



# EMP

By Vaughn O. Martin

# ELECTRO

**Imagine a very bright flash in the sky! No one is hurt. But, your transistor radio stops playing, your car won't start, the telephone doesn't ring, lights stay off, and we find ourselves in the stone age!**

□ THE DEVELOPMENT OF MODERN HIGH-TECH SEMICONDUCTOR devices have paralleled unsettled relations between the nations of the world with resulting technological advances affecting the lives of every citizen of North America. Communications have been made faster, automobiles more fuel-efficient and maintenance-free, TV sets, videotape recorders, and virtually every other piece of electronics equipment have been improved by the advent of the semiconductor and its high-tech advancements. The relationship between nuclear weapons and the recent electronics advances may seem unclear, but a nuclear attack on the North American continent could make that relationship glaringly apparent.

All nuclear explosions produce electromagnetic pulses (EMP's) and the ensuing induced voltages and currents produced in conductors (wires and cables) are comparable in strength to the strongest lightning bolts. EMP's may reach 3 million volts and 10,000 amperes for a total of 30-billion watts of energy. The largest commercial radio stations in the U.S. and Canada radiate 50,000 watts, or approximately one-millionth that much power! The major difference between EMP's and lightning is that EMP's are induced simultaneously over an entire wide area, while lightning occurs at a single location.

## Significance of the Problem

Three ten-megaton thermonuclear weapons detonated 250 miles (400 kilometers) above the United States or Canada would produce EMP's strong enough to knock out the entire electrical power grid of North America including the entire civilian-telephone network, and just about every broadcast station. Virtually every piece of unprotected electronic equipment in the country—radios, TV sets, computers, electronic controls in homes, office buildings, factories, cars, airplanes, and instruments in hospitals—would be damaged, if not destroyed. The pulses would also damage or destroy large portions of the military command's control and communication (C3) system.

A chain reaction could be set in motion at nuclear power plants, due to electromagnetic pulses. Although it is a point that is frequently disputed, the possibility exists that reactor core meltdowns might occur as a result of EMP's. The meltdowns would be a by-product of electronic control system failure. The control systems are used to monitor and control the processes at the plants. The EMP's could cause the system to fail and result in partial or complete loss of control over vital functions, causing subsequent meltdowns. We know that those nuclear plants are designed to fail safe, but has anyone considered the possibility of every circuit breaker in a plant failing at the same instant?

UPI/BETTMANN ARCHIVE PHOTO



# MAGNETIC PULSES

## Characteristics of EMP's

At an altitude of 250 miles, the gamma rays produced in the first few nanoseconds (billionths-of-a-second) of a nuclear explosion can travel hundreds of kilometers before colliding with electrons in atmospheric molecules. That kind of collision may take place in a region 2,000 miles in diameter and 6-miles thick. Electrons are accelerated by those collisions, a phenomenon referred to as the Compton effect; and upon reaching the earth's magnetic field, they set up electromagnetic pulses that radiate downward toward earth (Fig. 1). Due to the extremely large area of collision, vast amounts of ground area are exposed to electromagnetic fields with strengths up to 50,000-volts per meter. The ground area exposed to electromagnetic pulses could cover the entire continental United States and most of Canada by one nuclear blast; if not, certainly large regions such as New England would be electrically and electronically devastated.

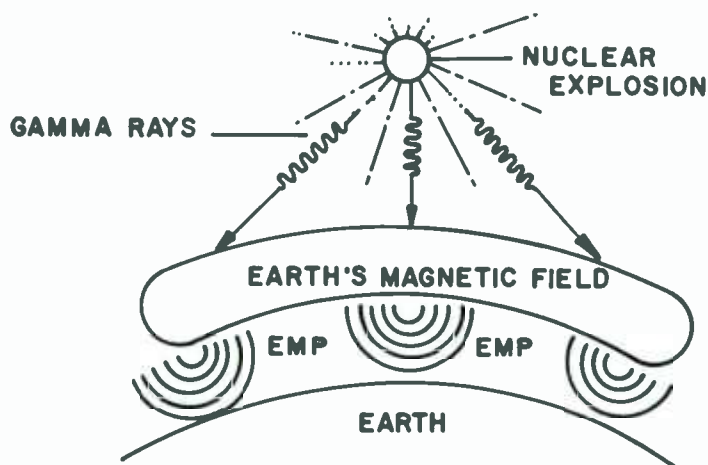

Fig. 1—Electrons set into motion by gamma rays from a nuclear explosion in space will produce enormous electromotive pulses (EMP's) when the negative charges enter the Earth's magnetic field. It is estimated that the ideal height for such an explosion should be 250 miles above the Earth's surface.

## Vulnerability

The effects that electromagnetic pulses would have on a mass of circuitry are difficult to predict because the interactions are complex. But, the more complex the components, the easier they are to damage. Power lines are one avenue for EMP damage, and a company making a shielded tubing to go over power and signal carrying conductors (Fig. 2) obviously had EMP in mind when they invented their Zippertubing. That covering acts as a partial shield to EMP's.

For each component, damage would come from the internal pickup of the circuit itself, as well as surges fed to it by all other attached conductors (power lines, other circuits, and metal parts).

Another concern is that generators and motors with their numerous internal windings of copper wire could be rendered useless in an EMP attack; and with subsequent inoperative water pumping stations, desert population-centers could per-

## GLOSSARY OF TERMS

**Electromagnetic pulse (EMP)**—An electromagnetic field of high intensity and short duration that may be caused by a nuclear explosion.

**Electromagnetic field**—a magnetic field produced by electricity (the flow of current in a wire or electrons through a medium such as air or a vacuum. It is usually expressed in volts per meter.

**Electromagnetic compatibility (EMC)**—the ability of an electronic device to deal with electromagnetic interference and function properly.

**Electromagnetic Interference (EMI)**—any adverse effect on electronic equipment due to an electromagnetic field.

**Shielding or Hardening**—a method used to protect electronic devices from EMP interruption or damage.

ish. In the dead of winter, motors in heating units would be destroyed and the chilling freeze in the northern portions of the North American continent would bring those areas to a standstill. Food and fuel shipments would halt because fusible links and electronic ignitions would be destroyed in cars and trucks. It's difficult to conceive a family anywhere on the continent not suffering extreme hardships.

The more complex the electronics components, the more vulnerable they are to electromagnetic pulses. Hardness describes the vulnerability of an electrical device and it is best for old-style vacuum tubes, less for semiconductors, and even less for microcircuitry. It would take 100 times more EMP energy to damage vacuum tubes than transistors and 10,000 times more energy to damage the tubes than integrated circuits. Computers may be upset through memory erasure with 100 times less energy than required to damage integrated

Fig. 2—One technique for shielding wires and cables from the effect of an EMP is to shield it with a product known as Zippertubing. The product's outer material is conductive.



MOTORS AND TRANSFORMERS  
 VACUUM TUBES  
 LOW-POWER TRANSISTORS  
 INTEGRATED CIRCUITS

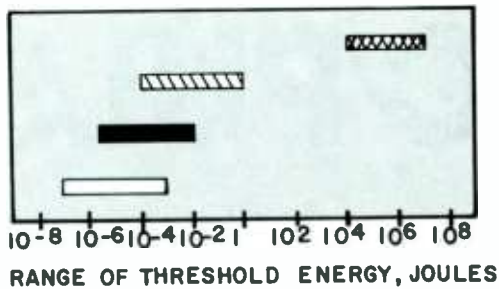

Fig. 3—The chart displays a comparison of several electronic devices versus their vulnerability to electromagnetic pulses. It is obvious that integrated circuits and semiconductors would require the most amount of shielding from damaging EMP's.

circuits; refer to Fig. 3. Aircraft in the air and parked on open surfaces would be disabled, because electronics controls the crafts' flight instruments and control surfaces.

EMC) measurements and evaluating protection devices. Refer to Fig. 4.

### Hardening Communications Equipment

### Shielding Methods

Hardening of electronics communications equipment is vital to the military, and, to a lesser extent, the civilian populace. The Department of Defense has established an Electromagnetic Compatibility Program (EMCP) to ensure that all military Communication-Electronic (CE) equipment subsystems, and systems are protected from electromagnetic interference of all kinds. That program was implemented to ensure that electromagnetic compatibility is maintained through design, acquisition, and operational phases. Numerous semiconductor manufacturers now produce what are called *radiation-hardened* integrated circuits, just for that reason.

In order to predict the effect of an electromagnetic pulse on electronic equipment, it is necessary to assess the environment. The structures housing the electronic equipment are made in various shapes and sizes, and are connected to the outside world by conductors such as utility lines and pipes, communication lines, and access and ventilation structures. Refer to Fig. 5. That combination of criteria makes the exact determination of the interaction of an EMP with such a variety of structures extremely difficult. However, for complex systems, it is convenient to have several layers of shielding. Refer to Fig. 6.

There are three major design criteria which must be considered when hardening against EMP's. They are cost, the equipment's ability to survive EMP, and failure rates of the shielding components.

### Shield 1

Cost includes both installation and maintenance. Some protection practices, such as shielding the entire communication site, may be attractive from a technical point of view, but are impractically expensive.

A structure composed of a great deal of metal is well shielded against electromagnetic pulses, while a building made primarily of wood is virtually unshielded against EMP's. Continuous, closed sheet-metal shields are, by far, the most effective electromagnetic shields. It is imperative that the internal environment of zone 1 be connected to the outside world. That fact makes a closed sheet-metal shield impossible. Apertures in shield 1 create a special problem in protecting communication sites from EMP penetration.

The electronic equipment's ability to survive an EMP attack must be measured in order to determine how much EMP protection is needed. A testing device for measuring the radiated electromagnetic susceptibility of an electronic device is a Transverse Electromagnetic Mode (TEM) cell. A TEM cell consists of a group of electronic instruments and a special specimen holder that simulates an environment of free space. The TEM cell is used for performing electromagnetic interference/electromagnetic compatibility (EMI/

The electromagnetic field penetration depends on the aperture size. If a given area of wall opening is subdivided into ten small openings having the same total area, the penetrating EMP fields at an interior point will be  $1/\sqrt{10}$  as large as for a single large opening of the same total area. Refer to Fig. 7. Therefore, it is better for a structure to have more small openings than just a few larger openings.

A common treatment for such openings is to cover them with a conducting screen or mesh so that the large opening is converted to a multitude of small openings (Fig. 8), or use a glass impregnated with metal (Fig 9). That glass, despite having metal in it, offers approximately the same degree of visual attenuation or lack of clarity as looking through a screen door from within the house.

### Shields 2 and 3

The second-level shield separates the internal environment from the sensitive small-signal circuits within the electronic equipment found within Zone 2. Shielding here may be accomplished by electrically grounding the metal cabinets and equipment.

Shield 3 involves the shielding of the interconnection of the equipment. That could involve elaborate design of interconnecting signal transmission lines. Fiberoptic signal transmission shows great promise here because it is not effected by any type of electromagnetic interference.

### Hardening Aircraft and Missiles

Generally, the EMP interaction with electrical systems



Fig. 4—The round piece of metal-flake, impregnated-plastic gasket in front of the Transverse Electromagnetic Mode (TEM) Cell specimen holder will be placed within the holder to measure its shielding effectiveness.

Fig. 5—A sealed metal box is an ideal structure for eliminating EMP penetration. However, power lines and signal cables require entry ports thus compromising the integrity of a shielded building. Obviously, it is apparent that doors and windows would have a greater leakage effect.

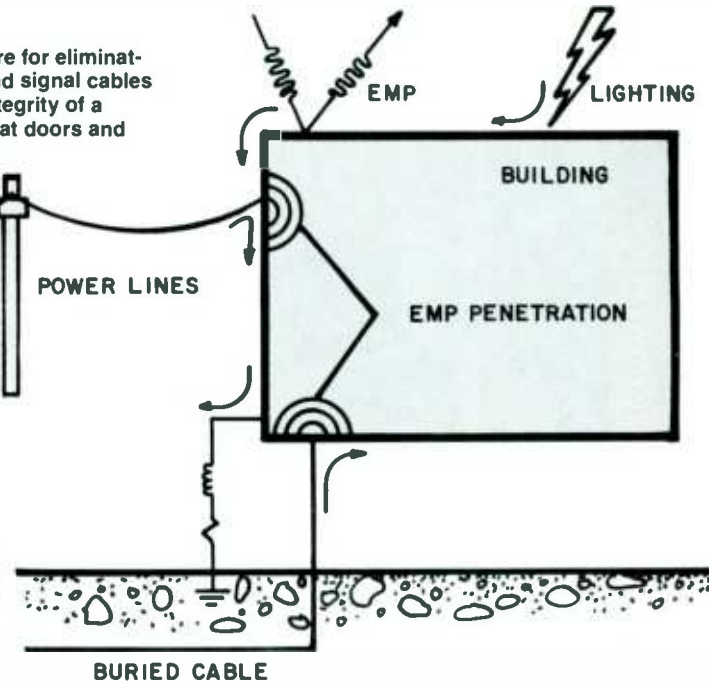
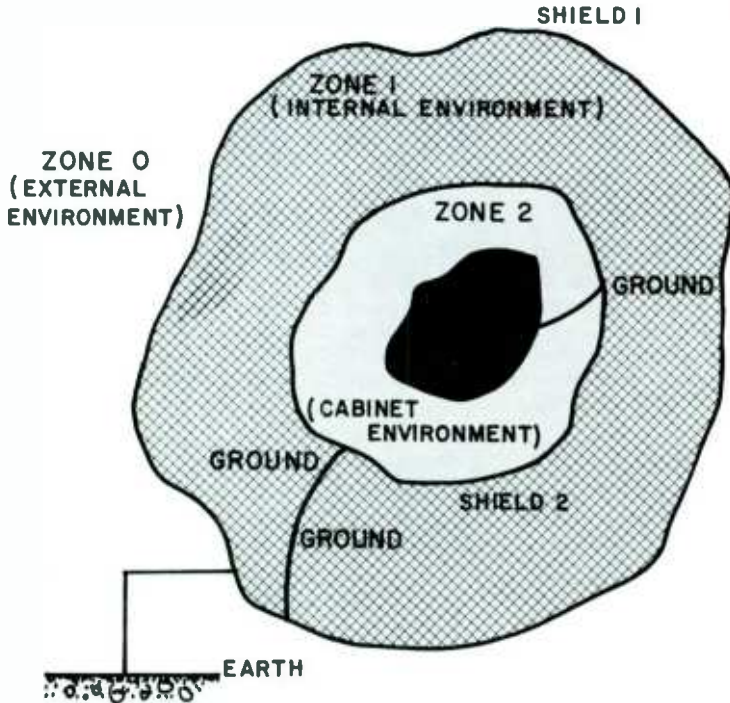

Fig. 6—More than one shield can be used to secure the environment of the machinery and electronic material contained within a building. The building can provide the initial shield. Shielded rooms or metal cabinets may provide a second shield. A third shield (not diagrammed above) would protect entry cables from violating the shielded area of zone 3.



inside structures such as aircraft and missiles depends upon a multitude of factors. Aircraft and missiles usually have a nearly complete metallic exterior covering that serves as a shield from electromagnetic fields. However, that shield alone is not enough protection against electromagnetic pulses. Missiles and aircraft are equipped with computers that cannot be upset even for an instant. They must be particularly well hardened.

At the present time, there is no agreement on the most effective ways to harden aircraft and missiles. Heavy shielding, like the type used at communication sites, is obviously impractical because of the added weight that the aircraft has to carry. Instead, EMP resistance is designed into the aircraft's equipment. One example of that would be in the area of circuit design. Small loops make better antennas for EMP's than short straight lines; therefore, circuits are designed in tree or branching layouts rather than in more conventional circuit loops.

Fig. 7—The electromagnetic field penetration into a ported shield is minimized by reducing the size of the openings. In the diagram the open area of the port of the example at left is equal to the sum of the areas in the example on the right. The diagram clearly shows that the penetration of an EMP is less when equal areas are summed from several small ports.

### Is Shielding Help on the Way?

In the last decade, electronic devices have proliferated in all areas of our lives. That influx of products has caused a problem: noise pollution, or EMI/RFI (electromagnetic/radio frequency interference). Over 80,000 cases of noise pollution were reported to the FCC (Federal Communications Commission) in 1982.

Strange as it may sound, the plastics industry is coming to the rescue with plastic electronic-equipment enclosures specifically designed for both EMI containment and shielding. Obviously, with EMP's as an external disturbance, the containment of a field is academic, but the shielding from an outside field is crucial. The parameter describing that is *Shielding Effectiveness* (SE) and the equation for shielding effectiveness is

$$SE = A + R,$$

or shielding effectiveness equals Absorbed plus Reflected energy.

Highly conductive materials such as pure metal shields reflect approximately 99 percent of the energy and absorb 1 percent. But plastics with metallic composite fillers, metallic paints and sprays, or even impregnated wire meshes still

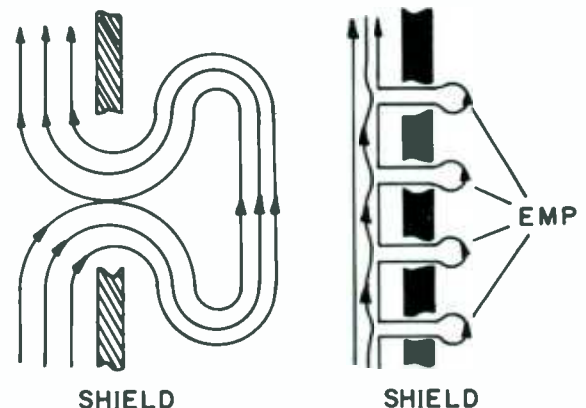

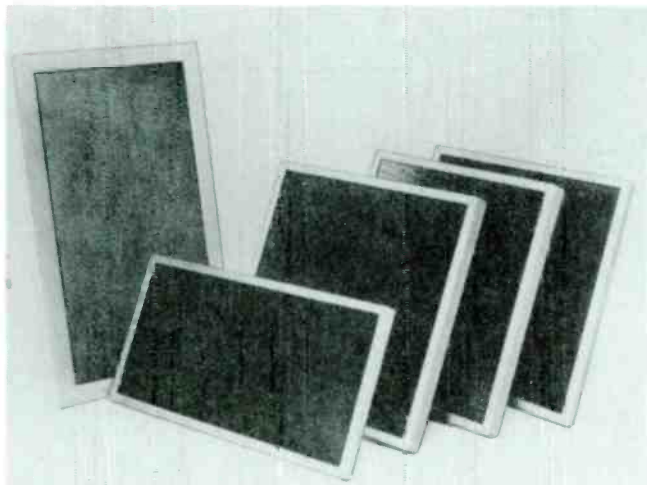

Fig. 8—Conductive screen of metallic mesh provides a multitude of micro-openings for a vented port so that the effect of an EMP is greatly reduced. Open mesh screens of this type are required for the flow of fresh air.

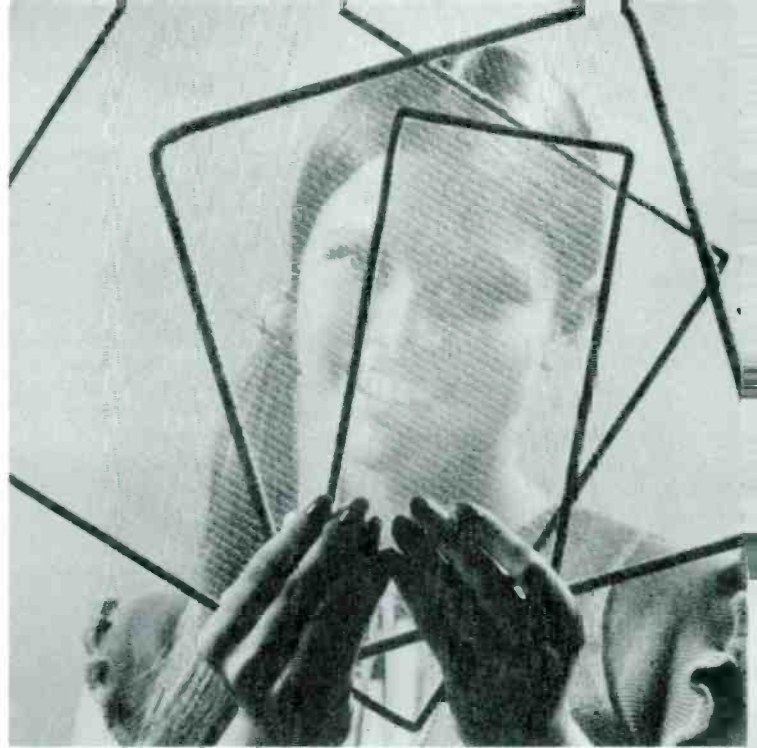
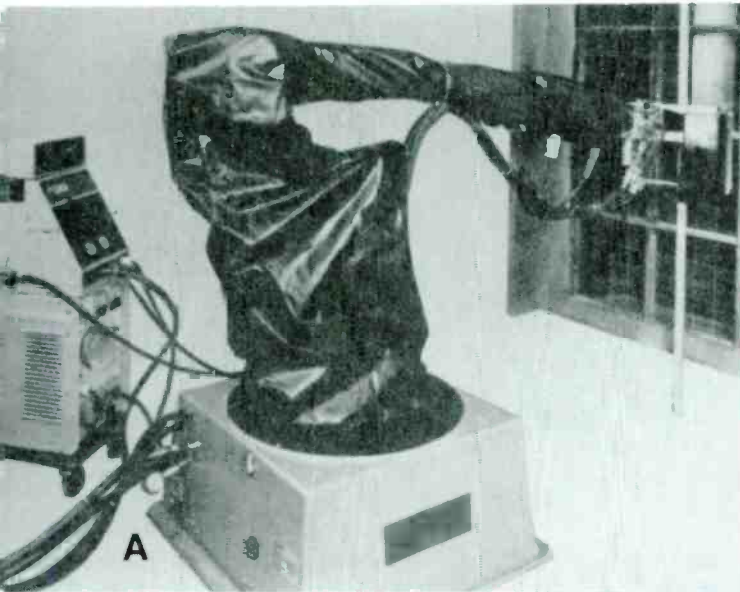
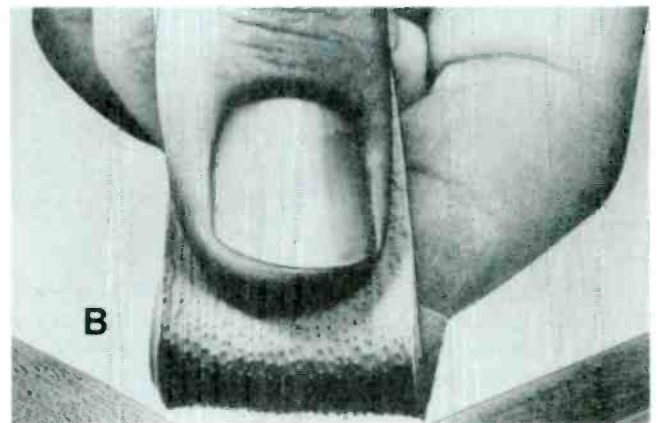

Fig. 9—Windows made from a glass with a metallic mesh pass light and permit outside viewing without providing that self-destructive port that will admit the EMP. Edge of window provides electrical contact for proper grounding to container or building shield.



A



B

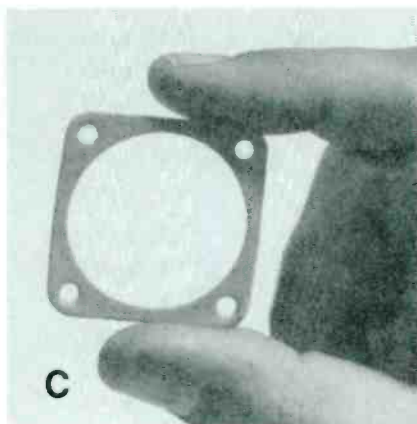

C



D

Fig. 10—Various methods and products can be used to protect electronic equipment. In (A) the robot arm is wrapped in a pliable plastic shield that contains metallic composite fillers; (E) adhesive-backed case liners adhere to cabinet door seams and the like to reduce inward electromagnetic leakage; (C) metallic impregnated gasket is used to join two metal fitting eliminating expensive machining of matching parts; and (D) conductive particle paint seals seams and breaks in metal shield surfaces quickly and economically.

**Fig. 11—A 12-foot roll of graphite-imbedded plastic is shown here being measured prior to cutting. This material can be used in interior walls as a secondary shield, or actually wrapped around equipment requiring protection.**

reflect 80 percent of the energy and absorb 20 percent. Refer to Fig. 10. If EMP's and the disturbing effects of electromagnetic fields still seem like an abstraction or a physicist's dream, consider that event.

A manufacturer of buses designed for city use had just delivered a fleet when, during a test drive, a problem was discovered. After going over the top of a hill, the driver tried to brake, only to discover he had no brakes until he got to the bottom of the hill. Upon logical investigation of that problem, field-strength meters demonstrated that a local television station had a lobe-shaped radiation pattern that intersected the hill's apex. The microprocessor-controlled anti-skid braking system on the bus had sensitive circuitry that became inoperative because of the TV signal. The bus, though, was made safe by properly shielding the enclosure housing the electronics. Refer to Fig. 11 and note how graphite, a moderately good conductor, is fabricated within large plastic sheets for applications such as that.

If a signal as small as that can effect circuitry that drastically, you can imagine what an EMP could do and likewise you can see how crucial EMI shielding is. But will EMI shielding be universally implemented into new equipment?

### **The Military's Involvement**

The military is very concerned with EMP's. The Army has established its Aurora Tree test facility in Adelphi, Maryland. The Navy has the Casino and Gamble-2 x-ray emitting facilities, but the Air Force probably has the most interesting project of all. It is called the Trestle, after the railroad structure it resembles.

That 12-story (118-feet) high, 58-meter (200-foot) square deck is flanked by a 50-foot wide adjoining ramp upon which aircraft to be tested are rolled up. Refer to Fig. 12. The Trestle can support aircraft weighing 550,000 pounds and is built with one-foot by one-foot wooden columns using no nails or metal of any kind. That largest glue-laminated structure in the world uses 250,000 wooden bolts to hold its six-million board feet of lumber together—enough for 4,000 frame houses. The structure at Kirtland Air Force Base, New Mexico cost approximately 58-million dollars.



The Trestle has two 5-million volt pulsers that discharge energy into wire transmission lines surrounding the aircraft under test. Sensors capture aircraft response signals and fiber-optic channels transmit that sensor data to computers for processing. The processing equipment, though, naturally resides inside a very well shielded structure. The B-52G's OAS (Offensive Avionics System) is one of numerous on-going studies directed primarily at testing the electronic hardening of military systems.

### **The Future**

The effects of EMP on our lives is becoming known to many on the North American continent as it is being discovered by all the citizens of the free world. Its political implications are not the topic here, but rather the facts in this article reveal to you what EMP is and what it can do to the technological devices we rely on every minute of the day. The next time a solar flare disrupts radio communications around the world for a few hours, or maybe a few days, recall that man with one nuclear device can outshine the damage old Sol creates by many fold. ■

**FIG. 12—The Trestle EMP facility can electronically stimulate the electromagnetic effects of a nuclear explosion on an aircraft and its electrical components during a simulated test. This aerial view shows a B-52 Stratofortress aircraft sitting atop the 200-foot square platform at the Kirkland AFB, New Mexico. (U.S.A.F. Photo)**

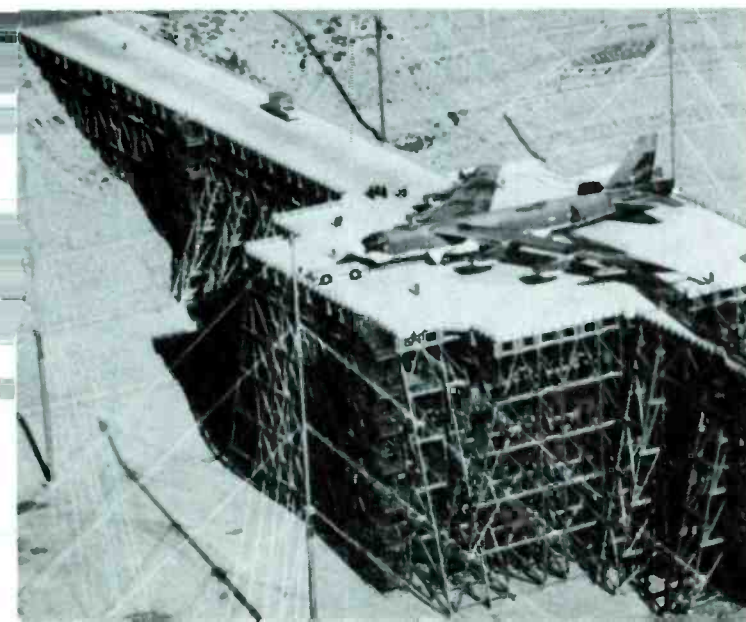

# Build this simple Waveform Generator

A one-IC, multi-output device with a 1000:1 tuning range for your testbench!

By Robert F. Scott

□ YEARS AGO, THE BASIC AUDIO/RADIO TEST INSTRUMENT was an ordinary high-frequency buzzer. Its audio-frequency output was rich in harmonics that were usable through radio frequencies up to around 3 MHz. Today, radios and audio equipment are more advanced and more sophisticated, so specialized test instruments are generally required. The basic waveform generator with its sine, square, and triangle waveforms is the instrument that now replaces the buzzer.

Here we introduce the Waveform Generator—it's simple, inexpensive, and very accurate when calibrated. Give it a try!

## How It Works

Figure 1 shows the circuit of a simple waveform generator designed around the Intersil 8038CC integrated circuit. Its frequency range is approximately 20 Hz to 20 kHz—a tuning range of 1000:1 with a single control. The output frequency depends on the value of C2 and on the setting of potentiometer R1. You can use other values of C2 to change the frequency range. Just remember that you increase the value of C2 to lower the frequency. The lowest possible frequency is around .001 Hz and the highest is around 300 kHz.

Figure 2 shows the parts layout we used for the waveform generator. Potentiometer R1, the FREQUENCY control can be mounted on a panel and fitted with a dial that can be calibrated. The DUTY CYCLE control, potentiometer R5, can also be removed from the breadboard and replaced on a panel by a standard potentiometer of the same value. That will permit you to vary the duty cycle

of the squarewave easily from about 2% to 98%. At the same time, the symmetrical triangular waveform can be varied to produce a sawtooth with fast-rise/slow-fall or slow-rise/fast-fall. The function and adjustment of potentiometers R5, R7, and R8 are discussed very soon.

Figure 3A shows the three output waveforms and phase relationships with a 50% duty cycle; while Fig. 3B shows the same waveforms with a squarewave duty cycle of 80%. The waveform amplitudes are related to the supply voltage. Sine-wave amplitude is 0.2 times the supply voltage; triangular waveform amplitude is 0.33 times the supply voltage, while squarewave amplitude is 0.9 times the supply voltage. Those signal levels are developed across 100,000-ohm resistive loads.

The power source can be a single supply of 9 to 30 volts or a dual supply of  $\pm 4.5$  to  $\pm 15$  volts DC. With a single supply, the three waveforms are above ground. When a split or dual supply is used, all outputs are symmetrical about ground.

## Construction

Putting together the Waveform Generator is simple and straightforward. You can do as we did and assemble the

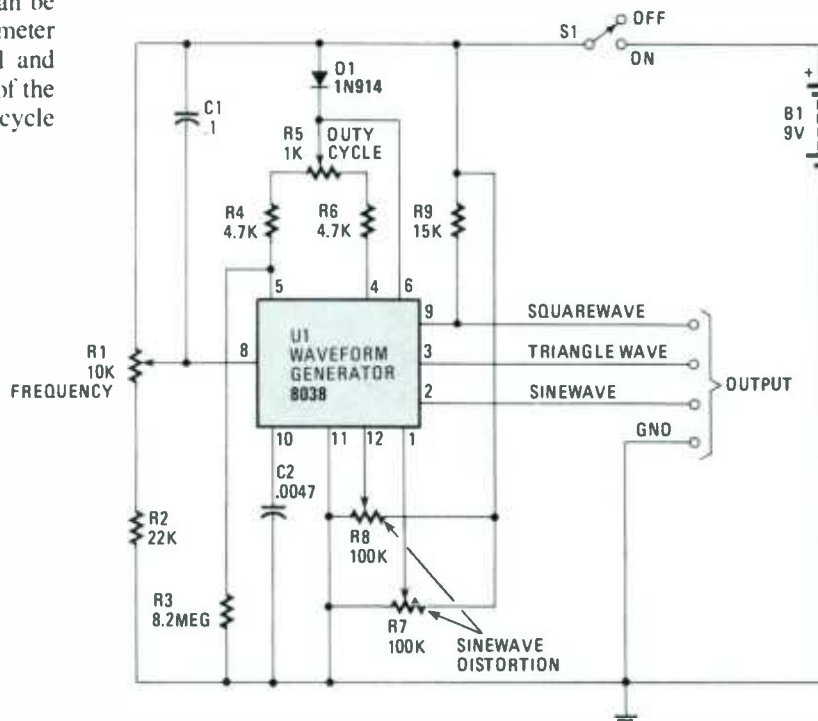

Fig. 1—The schematic diagram for this simple Waveform Generator, is based on the Intersil 8038 integrated circuit. The 8038 has an output-frequency range of 20 Hz to 20 kHz. Three standard waveforms (squarewave, sinewave, and triangular wave) are delivered simultaneously.

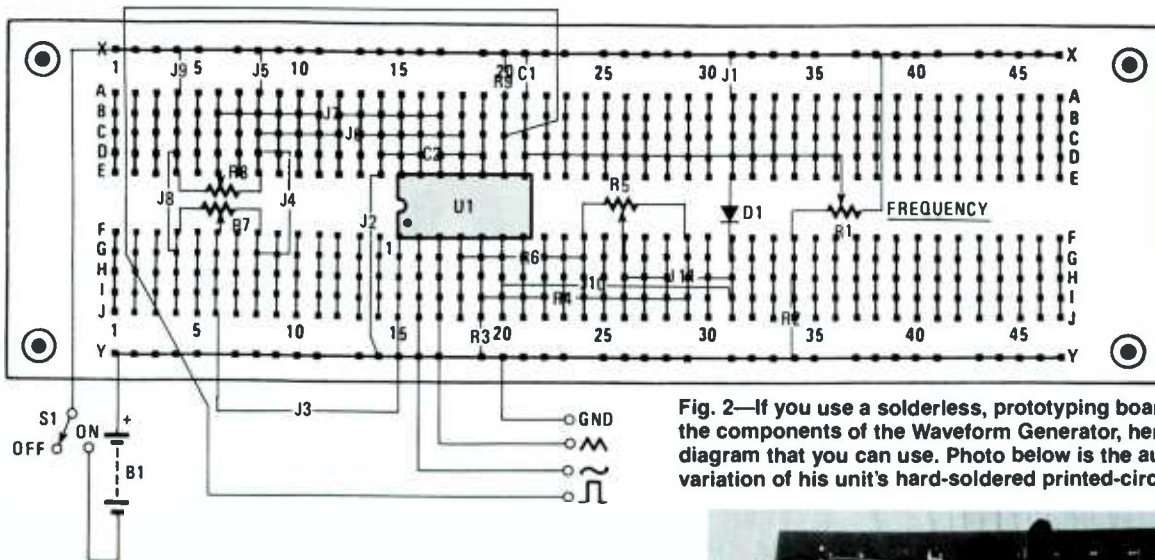

Fig. 2—If you use a solderless, prototyping board to mount the components of the Waveform Generator, here's a wiring diagram that you can use. Photo below is the author's layout variation of his unit's hard-soldered printed-circuit board.

generator on a simple prototyping board. You can then mount the generator, along with batteries or power supply, in a suitable case or enclosure.

When you first apply power to the generator, use a scope and check the squarewave output. Adjust the duty cycle for 50%, producing a symmetrical squarewave. With the scope on the sinewave output terminal, adjust the two SINEWAVE DISTORTION trimmers, potentiometers R7 and R8, for the best wave shape.

To calibrate the frequency dial, you can use an analog frequency meter, a digital frequency counter, or a scope. If the scope has a calibrated sweep, use that as a standard against which you compare the sinewave. If the scope sweep is not precisely calibrated, feed a 60-Hz line signal into the scope's horizontal amplifier and the generator's sinewave output into the vertical amplifier. The resulting Lissajous figures can be used to identify the sinewave frequencies as they relate to 60 Hz. Frequency ratios ranging from as low as 10:9 to as high as 10:1 are easy to identify.

When used alone, any one of the output signals can be used for signal tracing. When viewed on a scope, a squarewave pattern can be used to test an amplifier's signal amplitude, frequency response, and phase shift. The wider the amplifier bandwidth, the more accurate will be the displayed waveform. The squarewave that can be displayed without distortion will be ten times the low-frequency response at the -3 dB (cutoff) point of the amplifier under test.

If you'd like more information on the 8038 integrated circuit and its applications, see the Intersil Data Book and the booklet *Everything You Always Wanted to Know about the 8038*. The book is available from Intersil, 10710 Tantau Ave., Cupertino, CA 95014. ■

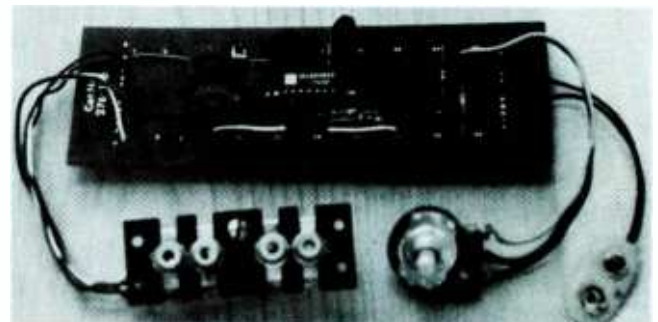

#### PARTS LIST FOR WAVEFORM GENERATOR

##### SEMICONDUCTORS

D1—1N914, 1N457, or similar

U1—8038CC Intersil waveform generator (Radio Shack Cat. No. 276-2334)

##### RESISTORS

(All fixed resistors are 1/4 watt, 5% units)

R1—10,000-ohm, linear-taper potentiometer

R2—22,000-ohm

R3—8.2-Megohm

R4, R6—4700-ohm

R5—1000-ohm, vertical PC-mount, trimmer potentiometer

R7, R8—100,000-ohm, vertical PC-mount, trimmer potentiometer

R9—15,000-ohm

##### CAPACITORS

C1—0.1- $\mu$ F, ceramic disc or polystyrene/foil

C2—.0047- $\mu$ F, polystyrene/foil

##### ADDITIONAL PARTS AND MATERIALS

Solderless prototyping board, wire, hardware, case, etc.

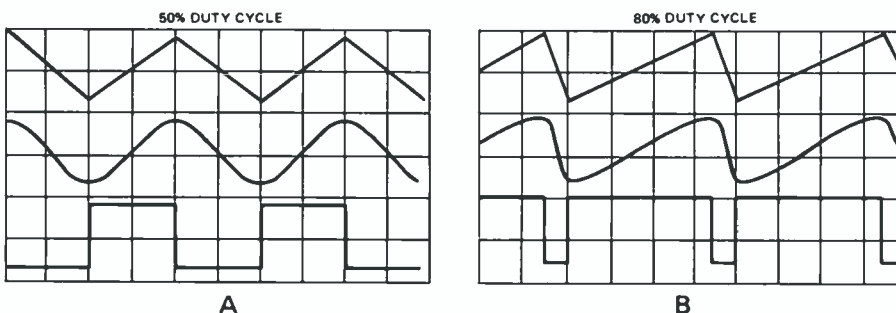

Fig. 3—Output waveforms—The waveforms and phase relationships that are shown in A result from a 50-percent duty cycle; with an 80-percent duty cycle, the resulting waveforms and phases are shown in B.

# Build JACOB'S LADDER

**A climbing electric arc has held the imagination of science-fiction fans as the symbol for an eerie laboratory!**

□ IN MANY *SCI-FI* AND HORROR FLICKS, ESPECIALLY THE stock Frankenstein variety, along with weird sound effects and the like, movie producers always feature the fantastic visual effects produced by Tesla coils, van de Graaff generators, and Jacob's Ladders. Now, of these three devices, using electricity to produce visual effects, the Jacob's Ladder is the easiest to build.

Putting together a Jacob's Ladder poses problems that normally do not occur with other types of projects. There's no need for a detailed parts list nor is there a need for a schematic diagram. We tell you how to build one as we reveal the theory of operation.

## Getting Started

As we can see in the photos, a Jacob's Ladder provides a fantastic visual effect. A beautiful electric flame (arc) hisses, pops, and slivers its way up two diverging wires, providing a fascinating, haunting, and downright scary effect. However, with a low-current neon-sign transformer, converted flyback transformer, converted auto spark coil, et al, you can whip together your own Jacob's Ladder with less than an hour of construction time. (The Editor made his Jacob's Ladder using the high-voltage transformer from his oil-burning furnace—a good idea during the non-heating season only!)

In the simple-as-possible Jacob's Ladder, there is actually very little to the construction and very few parts required. First, you need a high-voltage source delivering around 10 kilovolts—such as a neon-sign transformer or high-voltage power supply transformer at 30 milliamperes or more. The lower the current output, the less chance there is for building a fatal shock hazard. The higher the voltage, the larger

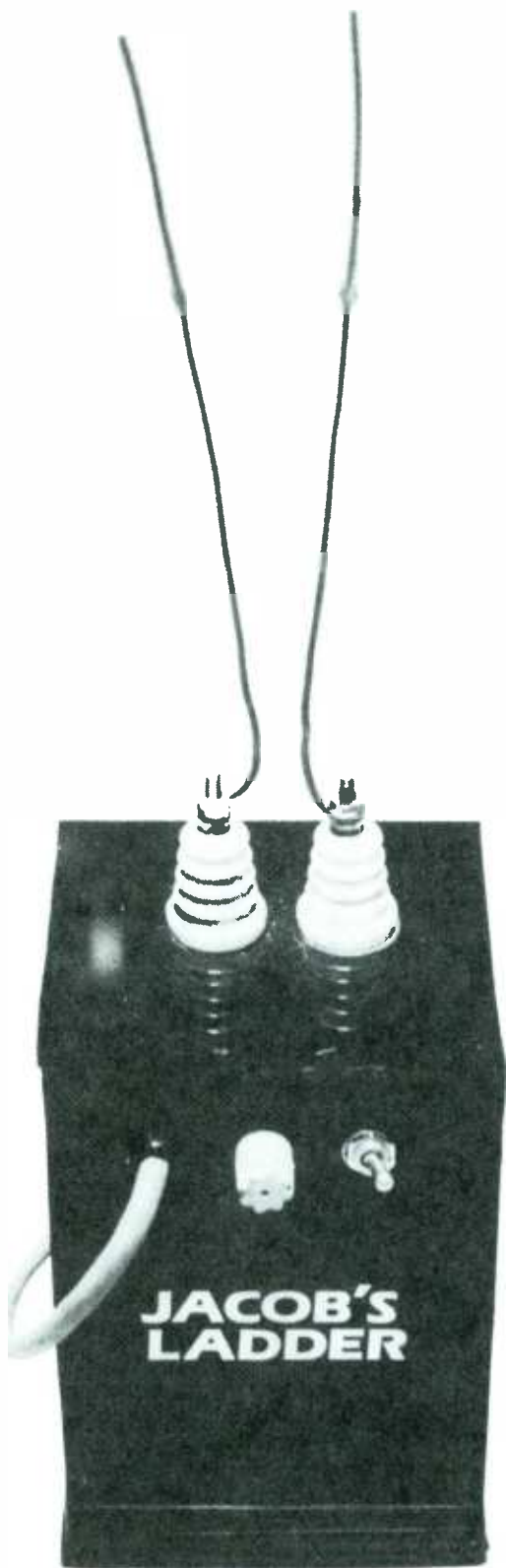

By James, Nicole, and Dwight Patrick Jr.

The author's assembled several Jacob's-ladder devices with the above being a typical unit. The high-voltage transformer is housed in a metallic case with the high-voltage electrical stand-off porcelain insulators mounted on top. The transformer inside the case is mounted so that the electrical contact between the transformer's secondary terminals and the bottom of the stand-off insulators are kept very short and void of sharp bends. You may want to locate the on-off switch a bit farther away from the electrodes. The electrodes can be lengths of #12 solid copper wire, available from any electrical hardware store. When removing the insulation be sure not to nick the wire.



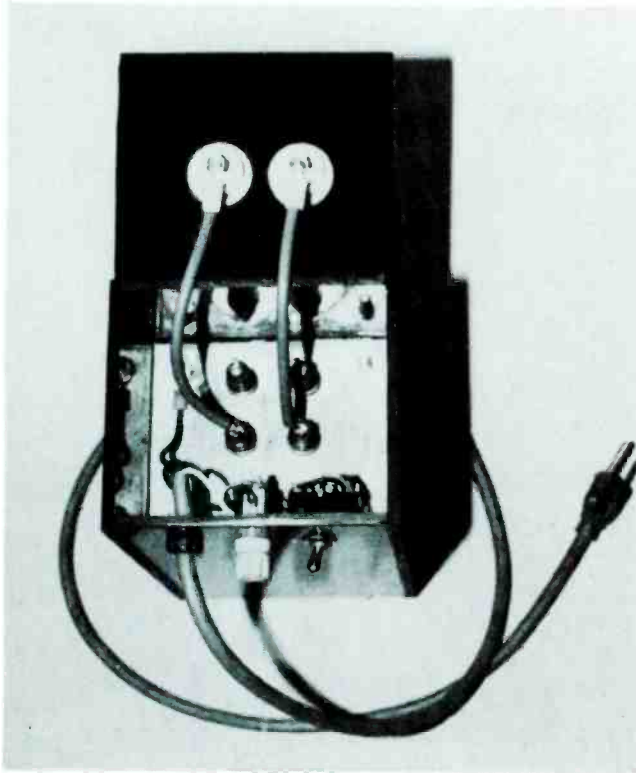

separation you'll be able to make at the top of the Jacob's Ladder *vee* electrodes, and the greater the distance the spark will jump across. The spark starts at the smallest distance between the *vee* electrodes (which is at the bottom), and the visible arc walks up to the widest gap at the top of the *vee* electrodes.

Why does the arc walk up the *vee* electrodes? As the first spark flies across the narrowest separation of the *vee* electrode, you would expect it to stay there where the electrical resistance between the electrodes is lowest. What happens is that the arc heats the air it passes through, causing the heated air (which is lighter than the air at room temperature) to rise. Because this heated air is ionized by the high voltage arc, it provides a very low electrical resistance path, and the current path rises with it. The cool air, that replaces the rising hot air, offers a higher resistance to the potential arc-over at the bottom of the *vee* electrodes compared to the rising arc path.

Eventually the arc reaches the top of the ladder (*vee* electrodes) and bows upward creating an electrical path that gets longer and longer. At a point where the resistance to arc-over at the bottom of the *vee* electrodes is less than that of the arc-path resistance at the top of the ladder, the upper arc is distinguished and a new arc-over occurs at the bottom of the ladder. Thus, what is seen is a continuous climbing arc that disappears at the top of the ladder and reappears at the bottom at the same instance. It's all a lot of fun to watch, providing that you don't poke your finger between the electrodes or get your nose to close.

**The author's found some surplus plastic containers that could be used as a people shield so that inquisitive persons would not accidentally touch the electrodes or come in contact with the arc. You could make such a shield from sheet Plexiglas material. Be sure to include a vent hole at the top and bottom of the shield so that gasses produced by the arc are allowed to escape.**

**Here's a view of the Jacob's Ladder with the top lid removed to show the ultra-neat wiring. RTV cement was used around the high-voltage connection points to reduce coronas. The line cord includes a third lead, used to ground the case. That will provide a necessary protection against accidental shock. Always ground the metallic case of AC-powered projects as a safety precaution. Remember: You can receive a nasty jolt of high-voltage power from the unit's arc or electrodes.**

The high-voltage source should be placed in a case or cabinet which is a good insulator; or, if the case is metal, it should be adequately grounded. Both methods are shown in the photos. In one case, a 7-kilovolt transformer was placed in a 1/4-inch Plexiglas case with the primary winding connected via fuse and switch to the 117-volt AC input. The output of the transformer was then connected across two pieces of #12 copper wire, forming the actual *vee* electrodes through two porcelain feed-through insulators via some high-voltage TV anode hook-up wire.

Finally, exposed high-voltage points were given a coat of RTV silicon rubber to prevent any arc-over inside the enclosure. That method will work well with enclosed military-type transformers that are available on the surplus market; however, some transformers must breathe or they will overheat. In those cases, the enclosure must be large enough to provide for expansion and must be vented. Further, some underrated transformers may require an extraordinary cooling measure such as adding a fan for cooling. Those transformers should be avoided.

A 10-kilovolt neon-sign transformer in a grounded metal enclosure is used with a small autotransformer (a Variac type)

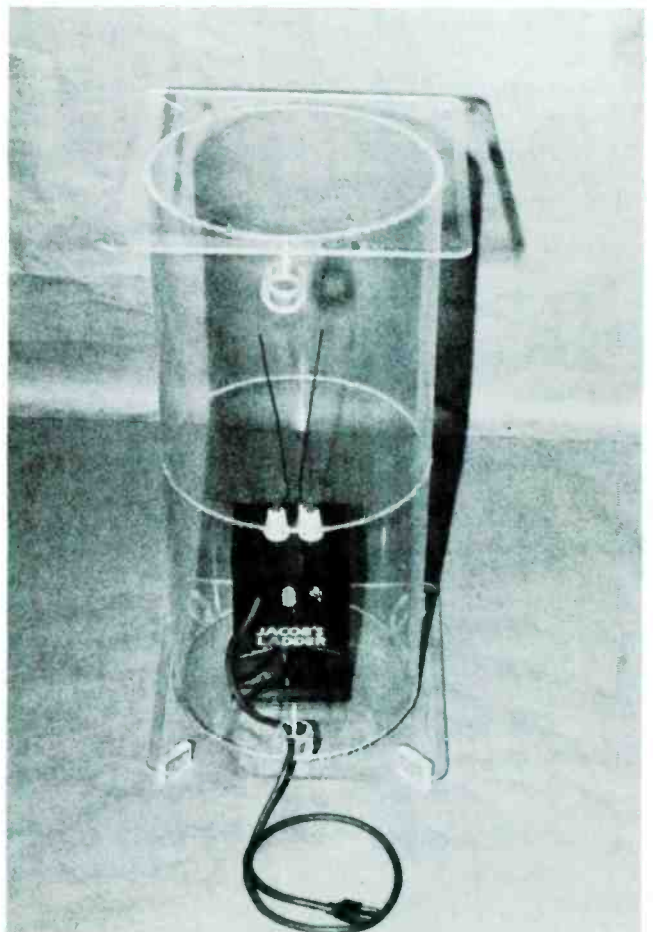

Another version of the Jacob's Ladder is shown here. The surplus transformer used in this model permitted the use of a baking-pan chassis with a low profile. This unit fitted inside a plastic cylinder available from a local Plexiglas supplier.

controlling the primary winding voltage input. Here, the output voltage has been made adjustable. Also, a different type of porcelain insulator is employed, with the high voltage brought to the top of a stand-off type insulator.

### Adjustment and Operation

The last step in getting your Jacob's Ladder to work is the adjustment of the two diverging wires forming the *vee* electrodes. There should be no attempt to make adjustments when the unit is turned on. The unit should be turned off and preferably disconnected or both when adjustments are made, to prevent accidental electrical shocks.

The two diverging wires forming the *vee* electrodes must be brought close enough at the bottom to establish the spark or arc-over, with the wires gently angling away from one another to form the "V" as they move upward. The initial distance at the base to start the spark will vary with the voltage applied, humidity, altitude, etc. So, it's pretty much a trial-and-error type of setup.

Start with the wires at the base an inch or so apart, when using 10 kilovolts or more, and move them closer in small increments on each succeeding try until an arc is established. But remember to kill the power before each adjustment, as mentioned above, if you want to be around to make the next adjustment.

When the distance is just right, the arc should just start. On the other hand, if an arc is established at the initial setting, move the wires apart until an arc is just sustained. Placing the wires too close together will *smoke* the transformer over time and the unit will ultimately either fail or not work properly.

When you have established the arc, if it does not move up between the two diverging wires, they must be adjusted in or out to get the snap, crackle, and pop desired. But, remember that it's better to be cautious than dead. Turn the unit off

before any adjustments and keep high-voltage transformer current as low as possible to prevent fatal shocks.

### Be Safe Than

Once your Jacob's Ladder is up and running, an extra layer of safety can be used to prevent acci-

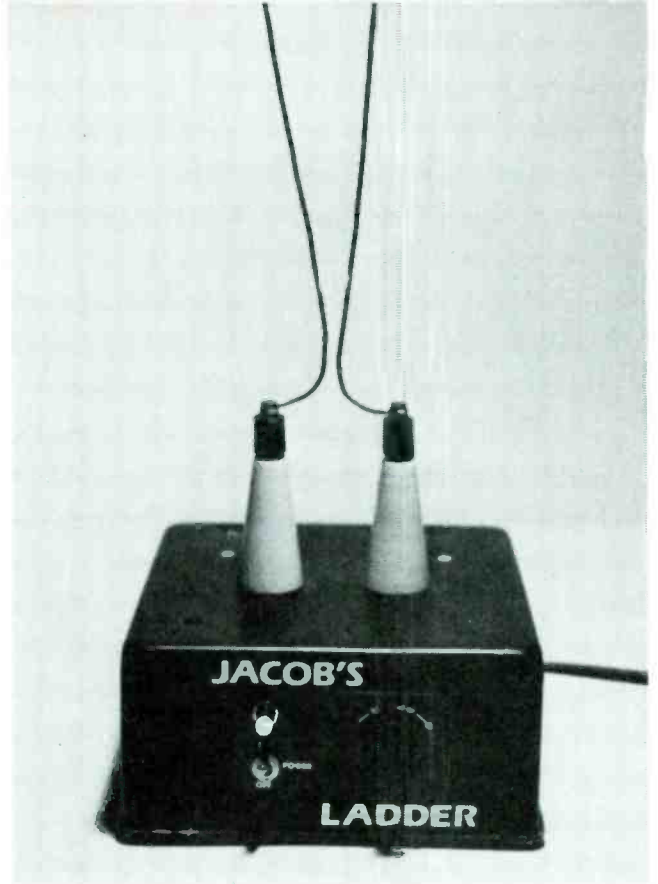

dental shocks. Add a clear Plexiglas or Acrylic cylinder around the entire unit to prevent the *unthinkable* from becoming *thinkable*. The clear plastic housing should have vent holes at both top and bottom to allow heated gasses to escape, but not so large that the smallest child in the family can get his or her mitts or anything else inside. Generally, those types of cylinders can be purchased from most plastic-hobby houses rather cheaply and are well worth the added protection, especially if there are any little crumb crunchers around.

Now that you have a Jacob's Ladder, use it. Comes next Halloween, place it in your window and turn it on every time the doorbell rings. Answer the door with a non-electronic rubber monster-mask and the chances are that the wee visitors may scoot down the front walk and never be seen again. Cruel? Not on Halloween! ■

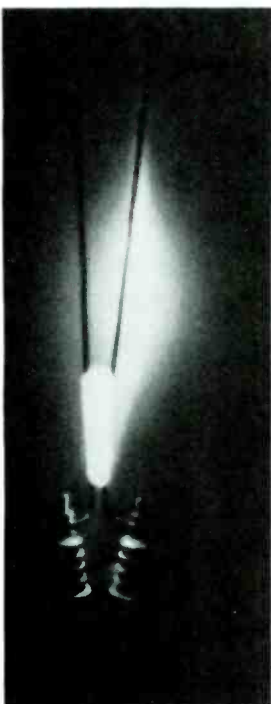

Here are two time-exposed photographs showing the development of an arc at the bottom of the ladder electrodes (left), and its climb to the top (right). You should display the Jacob's Ladder in a darkened room for maximum viewing effect.

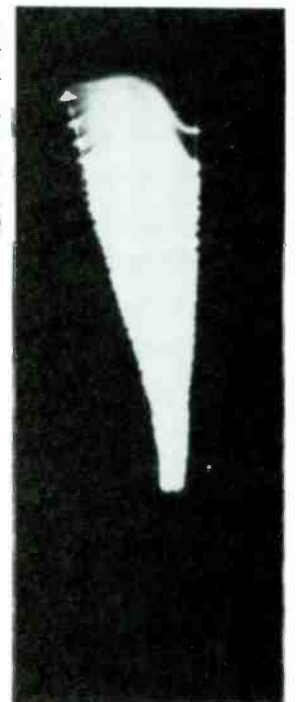

# Extension Phone Ringer

**Need an extension ringer for your telephone? Here's a nice one you can put together inexpensively in just a very short time.**

By Robert F. Scott

DO YOU FIND THAT YOU CAN'T HEAR YOUR TELEPHONE when you are working in your workshop or garage? The obvious solution to that problem is our Extension Telephone Ringer. But there's no reason to turn to the telephone company for one. Instead, you can build a modern electronic ringer, and all it will cost you is a few dollars and a couple of hours of time at your electronics workbench.

## The Circuit

The Extension Telephone Ringer circuit described in this article is very simple; it is a tone-ringer circuit and uses only ten components—and that includes the prototype board that it's built on! The circuit is based on Motorola's new MC34012 telephone tone-ringer IC. When connected to an appropriate transducer, that IC generates a pleasant attention-getting warble tone.

The schematic diagram of the extension tone-ringer circuit is shown in Fig. 1. The AC ringing-voltage, typically 40 to 90 volts at 26 Hz, is rectified by U1, the tone-ringer IC, and is used to drive that IC's internal tone-generator circuitry. The tone-generator IC includes a relaxation oscillator with a base frequency of 500, 1000, or 2000 Hz; and frequency dividers that produce the high- and low-frequency tones as well as the tone-warble frequency. An on-board amplifier feeds a 20-volt peak-to-peak signal to the transducer.

There are three versions of the MC34012 Tone Ringer. The MC34012-1 produces an 800/1000-Hz warble tone, the MC34012-2 develops a 1600/2000-Hz tone, and the

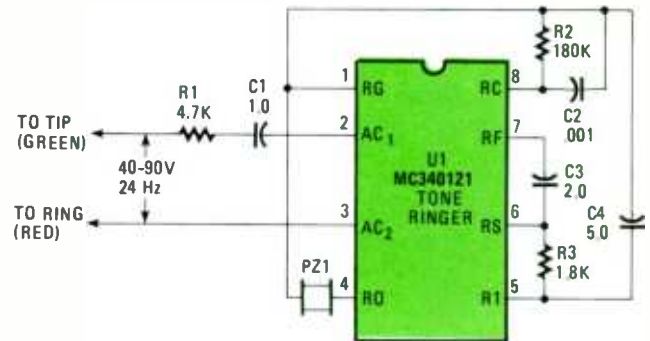
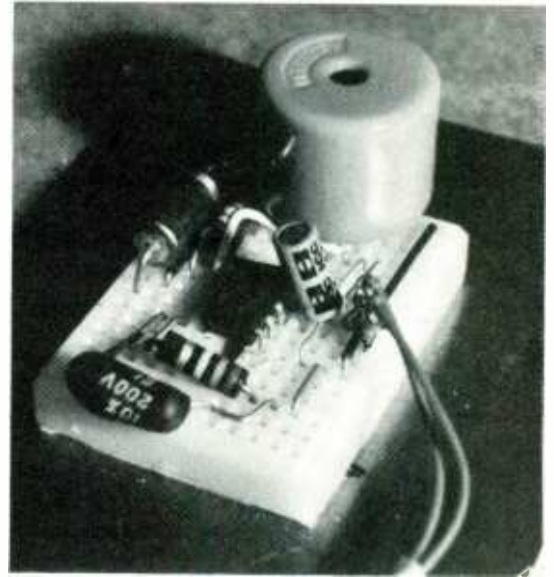

**FIG. 1—THE HEART** of the easy-to-build Extension Telephone Ringer is Motorola's new MC34012 IC (versions A, B, and C—see text) that is finding its way into hobbyists' hands.

MC34012-3 device has a tone warbling between 400 and 500 Hz. The warble rate for all three devices is 12.5 Hz. The frequencies of the warble tone are switched between  $f_0/4$  and  $f_0/5$ , where  $f_0$  is the frequency of the relaxation oscillator.

Resistor R1 and capacitor C2 control the frequency of the  
(Continued on page 98)

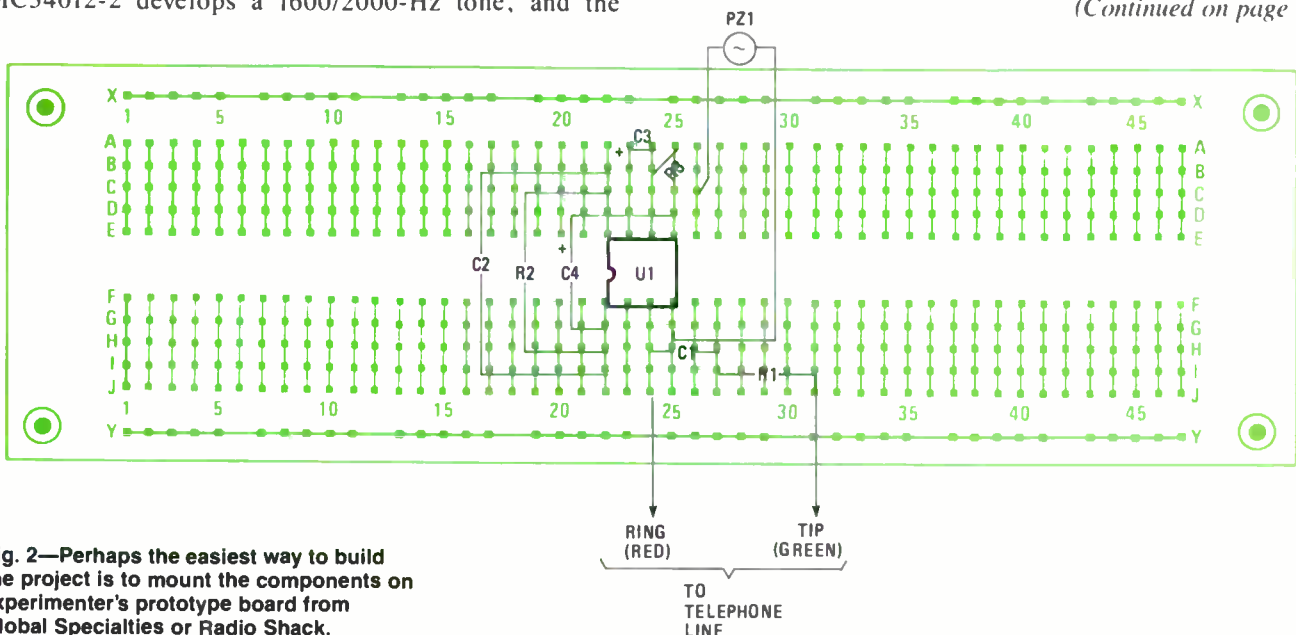

**Fig. 2—Perhaps the easiest way to build the project is to mount the components on experimenter's prototype board from Global Specialties or Radio Shack.**

# Good News from a Telephone Keypad

□ DEAF OR HEARING-IMPAIRED PEOPLE SOON WILL BE ABLE to use a telephone anywhere they go—thanks to a new, portable electronic device known as the Echo 2000. The device is easily attached to a handicapped person's telephone. Equipped with a liquid-crystal screen, it displays written messages tapped out by callers on the keys of their push-button (touch-tone) phones. At the deaf person's end of the line, the varying tones generated by the caller's push buttons are translated by special decoder circuits into letters that flow across the device's display window in ticker-tape fashion to spell out a message.

A patent covering the technology was awarded to the General Electric Company earlier this year in the name of inventor Edwin Underkoffler, a computer specialist at the GE Research and Development Center. He developed a device similar to the Echo 2000 to help a Center colleague communicate with his deaf son. Underkoffler has been involved with a number of local projects with the deaf in recent years.

The innovative device complements the teletype keyboard printers currently used by the deaf or hearing-impaired to communicate via telephone. The Echo 2000 is truly portable; it can be hooked up to a phone anywhere. Since it is self-powered, it will work even in a telephone booth. In addition, only the deaf or hearing-impaired person needs a device. Teletype keyboard printers must be located at both ends of the telephone line.

The key to the device is an integrated-circuit chip capable of decoding the various frequencies produced by push-button telephones. "I realized that the signals generated by this microchip could be employed to activate the appropriate letters of an electronic display. All that was needed was a code and the circuitry to make it work," Underkoffler pointed out.

While Underkoffler was busy developing the device, an electrical engineer named Stephen Fowler of Duncan, SC, was also hard at work trying to develop a communications tool that would enable him to be understood on the telephone by his hearing-impaired mother.

"When my father was alive, I had no problem communicating with my mother on the telephone, because my father would simply answer the phone and relay whatever I wanted to say to my mother, who is an excellent lip-reader," Fowler explained. "But after my father died, I was faced with a tremendous communications problem. I could communicate with my mother only in person—not on the phone."

Fowler developed a device very similar to Underkoffler's



This battery-powered device enables deaf people to use a telephone anywhere—even in a public booth. At the deaf person's end of the line, the varying tones generated by the caller's push buttons are translated by special decoder circuits into letters that flow across the device's liquid-crystal display window in ticker-tape fashion.

and then discovered that Underkoffler already held the patent. When Fowler called GE to ascertain its plans, he learned that the company was hoping to license the technology. For a nominal fee, Fowler then purchased the commercial rights to the innovation, which the firm he found (Palmetto Technologies) is now marketing.

The Echo 2000 is compact (7 in. × 4 in. × 1 in.), portable (it weighs only 10 ounces), and powered by four rechargeable batteries that allow at least six hours of continuous operation between recharges.

To talk to a deaf or hearing-impaired person, the caller must depress two telephone buttons for each letter—the first being the key on which the letter is located, the second being the number key (either 1, 2, or 3) to indicate the position of the letter on the key initially depressed. For example, to transmit the letter A, the user taps the middle key in the top row (which contains the letters A, B, and C), followed by the 1 key to indicate that it's the first letter in the series. To transmit the letter B, the user would first hit the same middle key and then the 2 key, and so on.

To transmit a number, a caller simply strikes the desired number keys and then the pound (#) key. In addition, there are abbreviated, two-button, codes for some of the most frequently used words. For example, 00 denotes *hello* and \*0 indicates *goodbye*. What is developing is a code similar to the ham's Q-signals.

Additional information about the Echo 2000, which sells for \$250, can be obtained from Palmetto Technologies, Inc., P.O. Box 498, Duncan, S.C. 29334. ■



Stephen Fowler communicates with his deaf mother, Mrs. Sue Fowler (right), by tapping the keys of a push-button telephone. A device attached to his mother's phone provides a ticker-tape read-out on an LCD. Edwin Underkoffler (standing left), a GE computer specialist, is the inventor.

# ON COMPUTERS



## FRIEDMAN

### Lightweight printers that burn and squirt!

□NOT EVERYONE NEEDS—OR CAN AFFORD—a letter-quality Daisy printer, a correspondence-quality matrix printer, or a high-speed line printer. While it's convenient to have any one or more of those professional-quality devices, they are both expensive and space-intensive. They often cost more than the computer, and their footprint—meaning how much table space is required—is often greater than that used for the computer.

Then again, a lot of personal computerists are often *on the go*, their personal computer often traveling along in the luggage. Dragging along a relatively large and heavy printer is at best inconvenient—usually more trouble than it's worth.

To meet the needs of those who can get by with a low-cost, lightweight, and miniature printer suitable for travel, printer manufacturers have resurrected an idea long considered obsolete, and they have adapted high-tech ink-jet printing into a mini-printer that will run on rechargeable batteries.

#### Burn! Burn! Burn!

The resurrected design is thermal printing, generally done on special *thermal* (heat-sensitive) paper. Back in the early days of personal computing, even a poor-quality, inked-ribbon printer cost *big bucks*. The pioneers of personal computing used the thermal printers, a device that *burned* characters into a specially prepared conductive paper called, logically enough, *thermal paper*. Instead of the printhead wires striking an inked ribbon, they simply moved against the thermal paper, which burned when a minute electric current was caused to flow from the wires, through the paper, to a conductive surface behind the printer. The results weren't all that bad: the problem was that the paper was unstable; after several months, it tended to turn brown until the characters blended right into the background.

A few thermal printers actually heated the wires so that they could burn the characters into ordinary standard bond paper—but the printed results were gener-

ally less than acceptable. Also, the carbon char produced by the burn often clogged the wires after just a few lines. One could usually tell if a thermal printer had printed a document by the missing *pieces* in the characters.

The introduction of low-cost, inked-ribbon matrix printers theoretically consigned thermal printing to oblivion. But thermal printers have one major advantage: they are relatively inexpensive to manufacture. For starters, most don't have ribbon mechanisms. And although they were almost entirely replaced for just about all serious purposes, models using narrow rolls of paper have always been available for very low-cost, home-and-family computers, though IBM was to sell a standard-width model for their PCjr.

How could IBM sell a thermal printer for serious use? Because, as with everything else, there have been great strides in thermal technology. Thermal paper no longer fades, turns brown, or disintegrates in a matter of months. In fact, decent, acceptable results can often be attained using ordinary bond paper. Also, with people generally more conditioned to computers, the not-so-perfect bond and

thermal paper printout is acceptable when nothing else is available.

Because thermal printers can be made compact, light, and cheap, several models have been recently introduced specifically for use with portable computers. Most are powered by rechargeable batteries and have standard Centronics or RS-232 serial I/O. Some will accept standard 8½-in. × 11-in. single sheets or roll paper 8½-in. wide, and all are relatively small and light.

#### The Roundup

Heading the list, of course, is the serial IBM Compact Printer, which accepts many of the control codes of *standard* matrix printers. It will underline, and it will print double-width, compressed, and scientific and Greek characters; and, most important, it has a bit-image graphics mode. Though its characters and symbols are meant to compliment the IBM personal computers, its functions can be attained with any computer. The Compact Printer uses sheet conductive thermal paper. The problem with the printer for general use is that it requires a special adapter cable, and

(Continued on page 101)

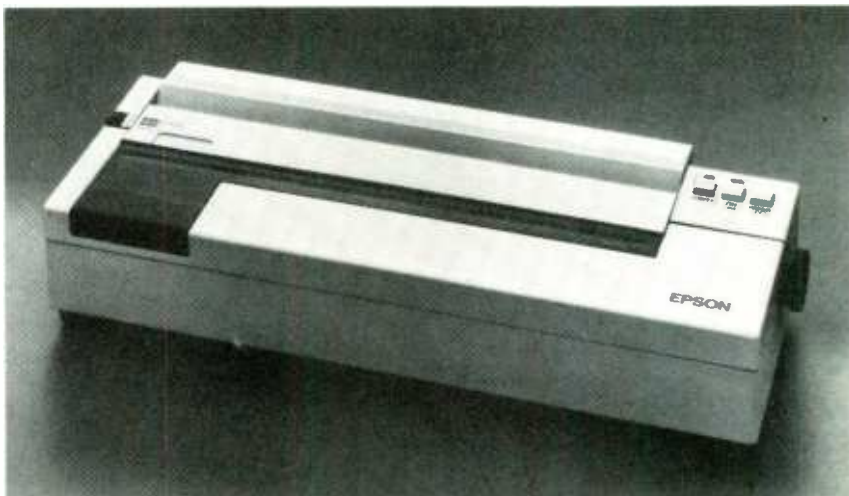

A new slim and lightweight 80-column printer developed for use with the new Epson Geneva/PX-8 portable computer provides thermal printing at 45 characters-per-second. Retailing at \$275, the 9-pin dot-matrix printer can accommodate bond or thermal paper.



If a color computer is retrofitted with a video adapter, as described in this how-to article, the viewing monitor may be either the conventional TV set (B&W or color) or a standard composite color or monochrome video monitor.

□ IF YOU'RE A TYPICAL USER OF A RADIO SHACK COLOR Computer you are probably very satisfied except for the video monitor, a TV set that generally has herringbone interference which makes a long computer session tire the eyes more than necessary. And it is the same TV set with its limited frequency response that *fuzzes* and *smears* the 63 and 80 character-per-line displays of the high-performance word processors such as Telewriter-64 and VIP Writer. While the TV set can just about resolve a 50-character display, the TV set makes the small characters used for 63 columns fuzzy, while 80 characters get blended into a mass of white splotches.

But there's really no reason to put up with a second-rate display from what is otherwise a first-rate personal computer. Since both screen interference and low resolution are limitations of the TV set, all it takes to eliminate the screen interference and to improve overall resolution is to provide the CoCo with a direct composite video that drives a conventional computer monitor.

The video adapter is supplied as a completely assembled unit. The interface between the adapter and the computer is through a prewired DIP socket that gets installed *sandwich-like* between one of the CoCo's integrated circuits and its socket.

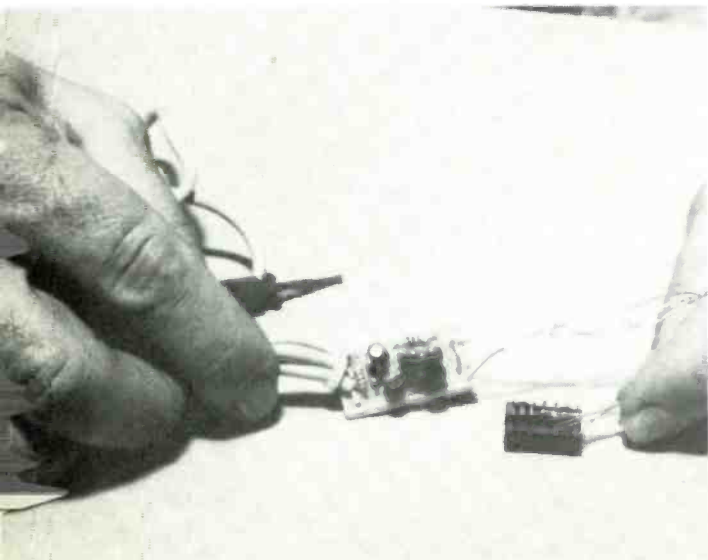

# ADDING DIRECT VIDEO to the COCO

By Herb Friedman

While you can always muck your way through a home-brew composite video-output modification to the CoCo's circuit board, an easier way to add a composite video output is to install a retrofit video adapter, such as the *Video Plus Monitor Driver* (Computerware, Box 668, Encinatas, CA 92024). The retrofit often involves nothing more than a plug-in installation; at worst, three connections to the CoCo's main circuit board.

Unlike computer retrofits that substitute one function for another, the *Video Plus Monitor Driver* doesn't alter the computer's normal output on TV channel 3 or 4. After installation of the video adapter, the CoCo has both its original TV RF output and a composite video output, neither of which gets in the other's way. In fact, you can use both outputs simultaneously. The *Video Plus Monitor Driver* adapter is available in two versions. One is for the older Model I CoCo—the one with the *gray* cabinet. It provides both a color and monochrome composite output and simply

The audio input to the video adapter is through a mini-clip that is attached to the audio-input lead of the computer's video modulator. Find it and examine its plastic collar, sliding it back and forth to understand how it operates.

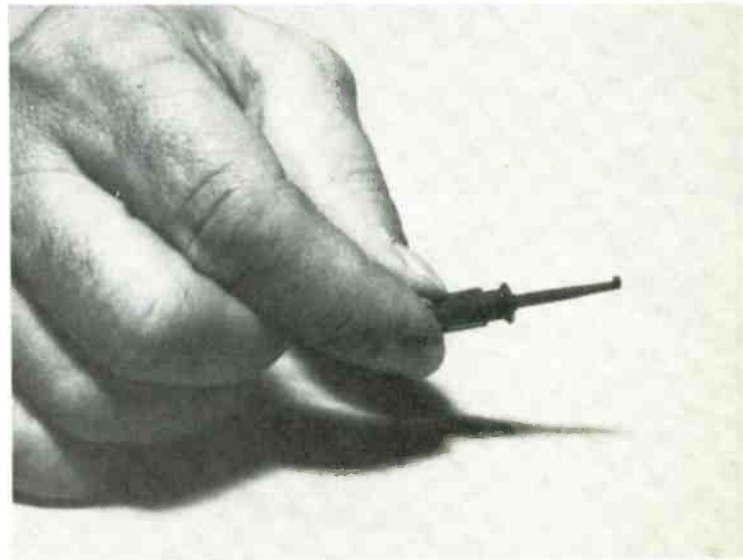

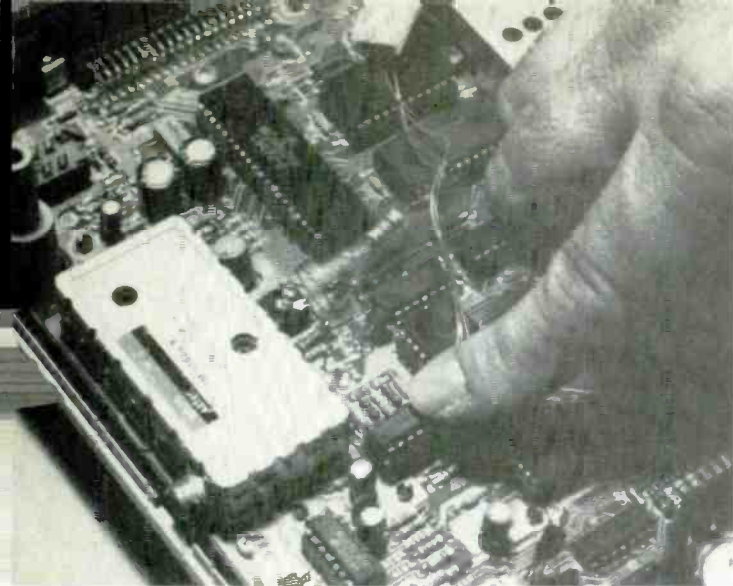

The actual location of the MC1372P integrated circuit varies slightly from Radio Shack Color Computer model to model, so double check very carefully that you're working on the correct integrated circuit.

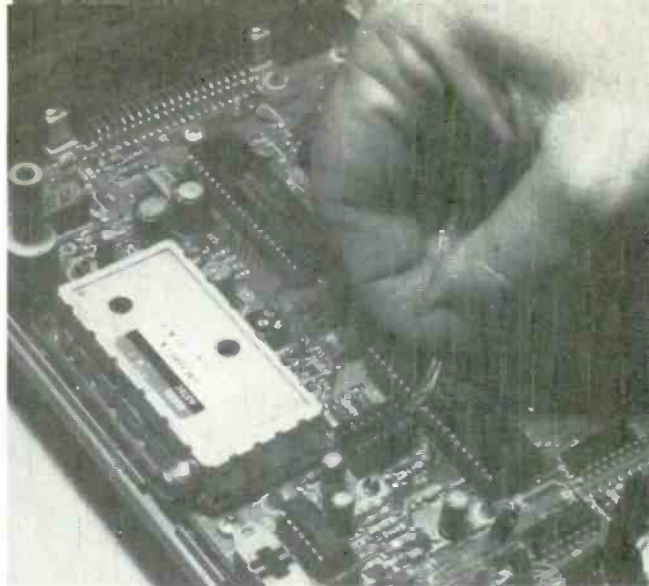

Carefully remove the MC1372P, and then, even more carefully, install the video adapter's pre-wired DIP socket. Make certain that none of the video-adaptor socket's terminals fold under. Then reinstall the IC in the DIP socket.

plugs into the computer. The retrofit for the newer Model 2 CoCo requires three minor soldering connections, and unlike the Model 1 retrofit, the output for the Model 2 is monochrome-only (black-and-a-white).

Installation of the composite video adapter takes about 15 to 30 minutes (depending on your skill) and requires no special tools other than a *groundstrap*. The instructions supplied with the adapter only mention that the installer should take reasonable precautions, because the computer components are sensitive to static electricity. But if you want to save the computer from possible expensive-to-correct damage, use a *groundstrap* when working on the computer.

A *groundstrap* is a wire that connects you to the electric ground (earth) at all times. You can make one easily enough by splicing a 1-megohm resistor of any power rating into a length of insulated flexible (stranded) wire, soldering a small alligator clip to one end, and connecting the other end to the nearest electrical ground. That is usually the small screw that

Hook the mini-clip on the video modulator's audio input, which is the second wire from the front. Pull back the hook's plastic collar, snag the exposed metal hook and release the collar. The clip will close, fully insulating the connection.

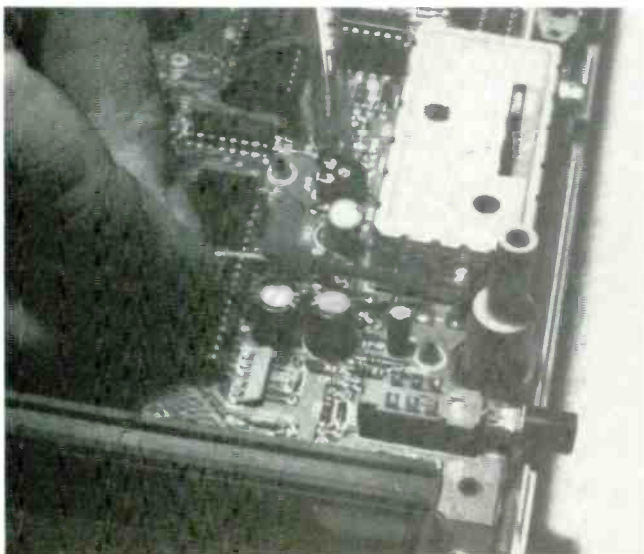

secures a metal cover plate to an electric outlet. Securing the clip to your metal watchband grounds any static charge that might accumulate in your body from wearing a wool sweater, walking on a carpet, or stroking the family cat. If your watchband is leather or plastic, secure the clip to the small metal buckle. If you don't wear a wrist watch wear one now, because you want to be grounded when working on the computer.

### Small, but effective

The video adapter doesn't look like much when it's first unpacked. It consists of a very small printed-circuit board with a few components, a DIP socket that's connected by short wires to the printed-circuit board, a miniature insulated hook-clip also prewired to the printed-circuit board, and two output cables—one cable with a phono plug for composite video output, the other cable with a phono jack for the sound output. *(turn page)*

Remove the protective strip from the double-sided adhesive on the bottom of the video adapter and affix the adapter to the top of the video modulator's shield. The *stickum* grabs tight, giving you only one chance to do it right!



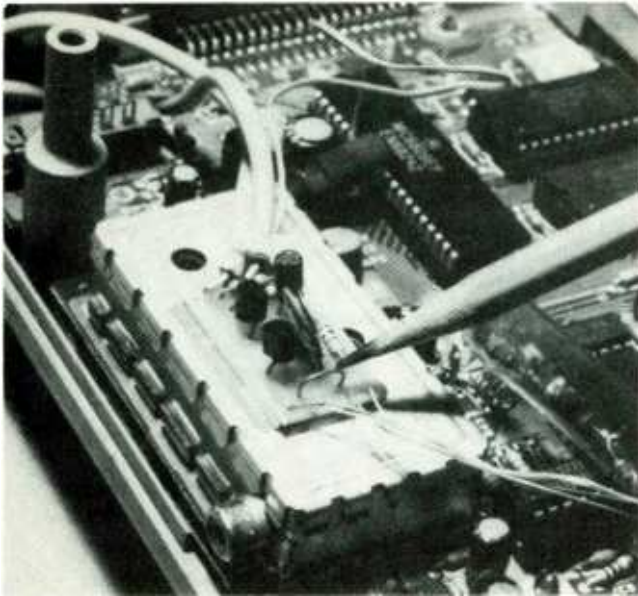

A wire loop on the video adapter determines the color/monochrome mode for both the video and RF outputs. When the loop is intact, both outputs are monochromatic. Cut the loop if you want color from both outputs.

## Installation

The first step is to remove the top of the computer's cabinet so you can get at the main circuit board. Make certain that the power plug is disconnected; place the computer face down on the table, remove the seven screws that hold the cabinet together, and make a written note which holes had the short screws. What's that, you can only locate six screws and the case won't separate? No problem! The seventh screw is located under the Radio Shack sticker, the one that serves as the warranty seal. Take warning that breaking the seal voids the warranty if it is still in effect. If the computer is still under warranty it might be better to delay installation of the video adapter until the warranty has expired.

When all seven screws are removed, carefully turn the computer over to its normal position and even more carefully remove the top half of the case. There is nothing connected to the top half, so simply lift it up and off.

Locate the video modulator, which is the silver-color shielded module at the rear of the main printed-circuit board. Then locate the MC1372P integrated circuit which is immediately adjacent to the video modulator. Depending on the particular version of the CoCo that you have, the MC1372P can be just to the left of the RF modulator, or directly in front of the left edge of the video modulator. If in doubt, don't guess. Make certain you see *MC1372P* imprinted on top of the IC.

Note the position (location) of the notch on one end of the IC and then remove the IC using an *IC puller* tool. Don't attempt to remove the chip with your fingers; that will probably damage the IC's terminals, which will make it difficult, if not impossible, to re-install. If you don't have a puller, slip a small screwdriver under each end and gently pry upward evenly on both sides until the IC pops out of its socket. Take extra care that the screwdrivers are between the IC and its socket, not between the socket and the printed-circuit board. (Make certain that you are wearing your ground strap at all times from the moment you open the cabinet.)

Carefully align the notch in the DIP socket of the video

adapter with the end of the MC1372P's socket that also has a notch, and insert the DIP socket into the MC1372P's socket, taking extreme care that none of the fine wires attached to the DIP socket get snagged or damaged. Then reinstall the MC1372P in the adapter's DIP socket, again taking care that the notch is in the correct location. Next, secure the video adapter's printed-circuit assembly to the computer. A good location is right on top of the video modulator, as shown in the photographs. The printed-circuit board has double-sided tape on the bottom. Clean an area on the video modulator with alcohol, strip the protective film from the double-sided tape, and push the printed-circuit assembly down on the video modulator. Align the assembly right the first time because it's almost impossible to remove once it sticks to the video modulator's shield. Finally, as shown in the photographs, attach the audio take-off, which is the small insulated hook clip, to the audio input to the Video Modulator. Facing the computer so that the four input leads to the video modulator are on the right, the audio input is the second lead from the front. Simply pull back on the hook's plastic collar, snag the exposed metal hook around the audio lead, and release the collar. The clip will close, fully insulating the connection. Dress the hook downward toward the computer's printed-circuit board.

That's it. You are almost home. All you have to do is get the video and audio cables out of the cabinet. The best place to do that is to the left of the reset switch (as you face the rear of the computer). As shown in the photographs, about 1/2 inch to the left of the reset switch cut a small notch just wide enough pass the two output cables. Cut the notch with a hot-knife, or press the side of a running 1/4-inch electric-drill bit into the cabinet until the notch is deep enough to pass the wires. But don't install the top of the cabinet until the assembly is checked out.

## Monochrome or color

A small wire loop on the adapter determines the color/monochrome mode for both the video and RF outputs. When  
(Continued on page 96)

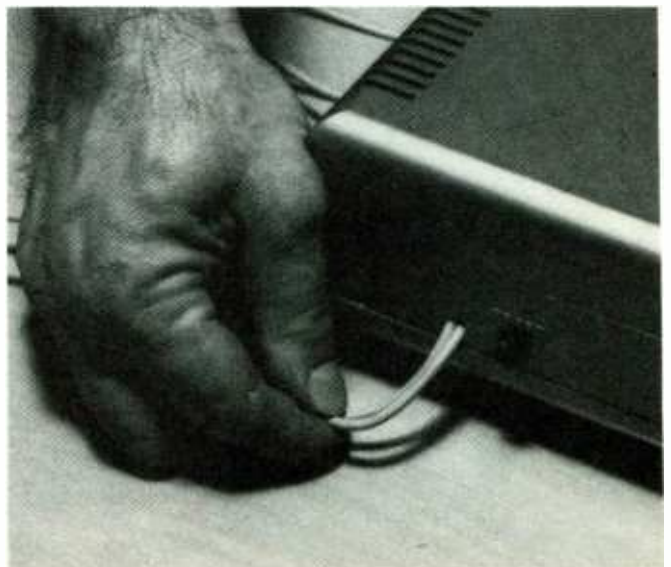

Both the audio and video wires exit out the rear through a small slot that is cut in the cover. The slot can be made by forcing the side of a rotating 1/4-inch drill bit into the plastic until the slot is large enough to clear the wires.





By Warren Baker

□WHILE YOU OR OTHER MEMBERS OF YOUR FAMILY MAY BE quite musically inclined and own a piano, organ, or other musical instrument, that instrument is quite likely to be *off limits* to the youngest members of your family. After all, jelly-covered hands rarely do an expensive musical instrument any good. If you would like to introduce a young child to the world of music, while safeguarding your own piano or organ, why not consider building a simple little organ just for him or her?

The Toy Organ described here is very simple to build and uses readily available parts. Most of the parts required can probably be obtained in Radio-Shack stores, if in fact, you *must* buy new items (many could very well be found in your junkbox). The type of enclosure used for the project is left up to you. You could buy a small hobbyist's enclosure if you wish, or build your own. It is even possible to have the unit installed into an upside-down cake tin. Your imagination can run wild here.

### How It Works

A schematic diagram of the Toy Organ is shown in Fig. 1. The musical device can span one complete octave from C to C-sharp. The tones are generated by the ever popular and

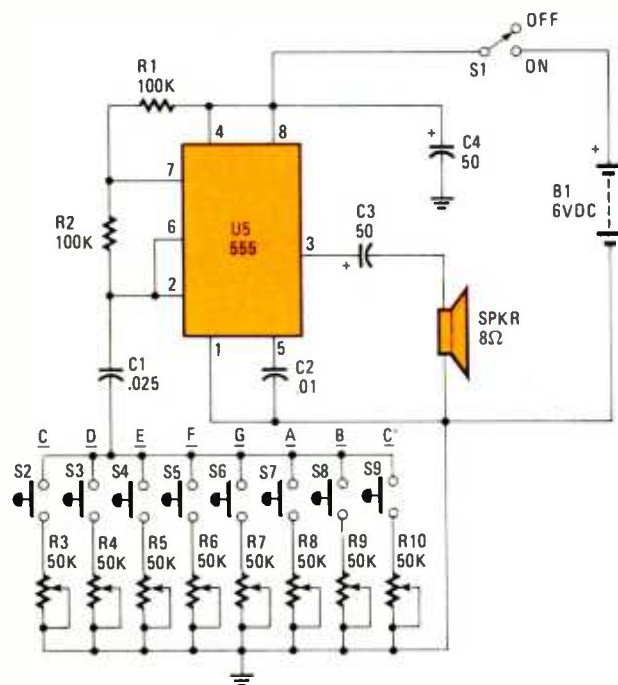

Fig. 1—The Toy Organ is a one-chip job that plays only one note at a time—chords are not possible. You can experiment with the values of resistors R1, R2, and capacitor C1 to get the sound you like best. To duplicate the scale you may have to compare tones to that of a tuned piano or guitar.

inexpensive LM555 timer IC, which is available everywhere. The circuit is fairly conventional, taken right out of the application notes with one little exception. The return (to ground) of the timing capacitor, C1, is routed to a bus-bar connected to eight momentary contact pushbutton switches (S2-S9). Those switches become the *keys* for our organ and may be mounted in a side-by-side keyboard configuration.

The other terminal of each switch is connected to one end of a 50,000-ohm trimpot potentiometer that is used to *trim* or *tune* the organ to each individual note of the scale to be covered. When a key is pressed, the circuit is completed and a tone, determined by R1, R2, the trimpot setting, and C1, is generated. Tuning each individual trimpot will allow you to bring the organ into tune with a piano or other instrument.

Note that the values of R1, R2, and C1 shown are not the only ones that will give satisfactory results. They are shown only as an example; if you wish, you can experiment with the values—in order to come up with a sound that you like the best. By the same token, there is little reason to use *precision* components because the trimpots will make up for any off-values of the timing circuit.

The unit is battery-powered, and requires a nominal 6 volts for operation. Use of C cells is recommended for longer battery life.

Note that no volume control is provided. Although no amplifier is used, it was found that the volume was sufficient for most rooms and it should be loud enough to satisfy most  
(Continued on page 97)

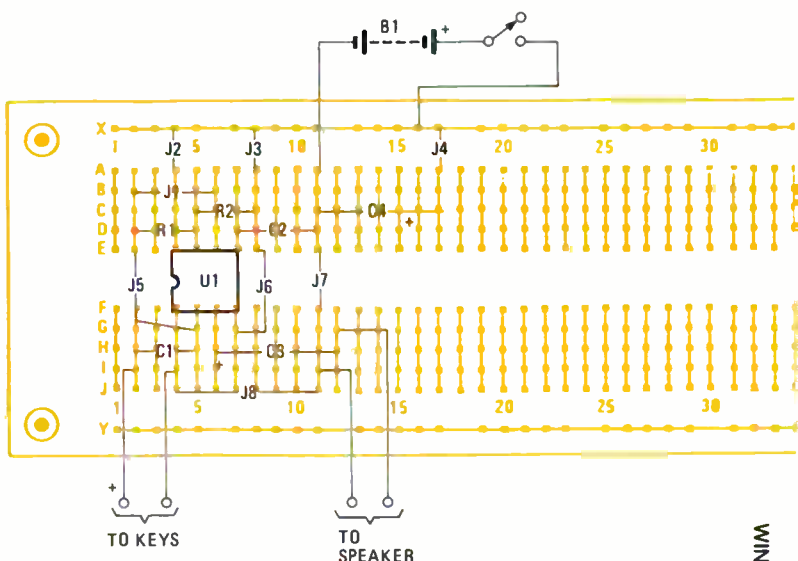

Fig. 2—Any construction technique can be used to build the Toy Organ. The prototype was built on solderless-circuit (prototyping) board and a suggested parts layout is detailed here.

# BRITISH HEE-HAW SIREN

By Robert F. Scott Add this Scotland Yard touch to your burglar-alarm system!

A PAIR OF TIMER IC'S ARE THE HEART OF A CIRCUIT THAT simulates the warbling *hee-haw* of a British police siren. The schematic diagram of the circuit is shown in Fig. 1. One of the 555 timers (U2) is wired as an astable multivibrator operating at about 900 Hz. The other U1, operates at approximately 1 Hz. Its output at pin 3 is a squarewave with a 50% duty cycle (on and off cycles of about 0.5 second each). The output of U1 is applied to pin 5, the CONTROL VOLTAGE terminal of U2.

The frequency of a 555 timer IC is relatively independent of supply voltage but can be varied over a fairly wide range by applying a variable voltage between pin 5 and ground. When

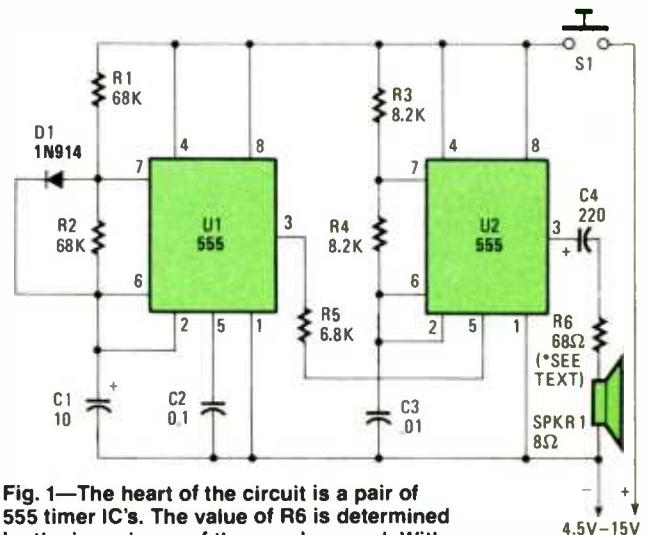

Fig. 1—The heart of the circuit is a pair of 555 timer IC's. The value of R6 is determined by the impedance of the speaker used. With an 8-ohm speaker, the value of that resistor is 68 ohms, as shown. For more information, see text.

U1's output goes low, U2 operates at about 1 kHz. When U1's output goes high, U2 operates at about 800 kHz. That switching between two frequencies produces the warbling *hee-haw* signal.

You can have quite a bit of fun by experimenting with various component values. For instance, you can vary the timing of the warbling by changing the value of C1 or by replacing R2 with a 200,000-ohm potentiometer. The range of frequencies covered by the warbling signal can be changed by selecting other values for C3.

When operating from a 15-volt DC supply, the 555 can deliver nearly 1 watt into a 75-ohm load, which is the ideal

(Continued on page 95)

## PARTS LIST FOR BRITISH HEE-HAW SIREN

### SEMICONDUCTORS

D1—1N914 diode  
U1, U2—555 timer IC

### CAPACITORS

C1—10- $\mu$ F, 25-WVDC, electrolytic  
C2—.1- $\mu$ F, disc ceramic  
C3—.01- $\mu$ F, disc ceramic  
C4—200- $\mu$ F, 25-WVDC, electrolytic

### RESISTORS

(All resistors 1/4 watt or larger, 5%)  
R1, R2—68,000-ohm  
R3, R4—8200-ohm  
R5—6800-ohm  
R6—See text

### ADDITIONAL PARTS AND MATERIALS

S1—SPST normally-open pushbutton switch  
SPKR1—8-ohm speaker  
Experimenter's prototype board (see text), 4.5- to 15-volt DC supply, wire, etc.

Fig. 2—To get the most of the "hee-haw" siren, you may want to build the circuit on some type of prototype board. That will let you experiment with various component values. Shown above is one suggested layout for the project.

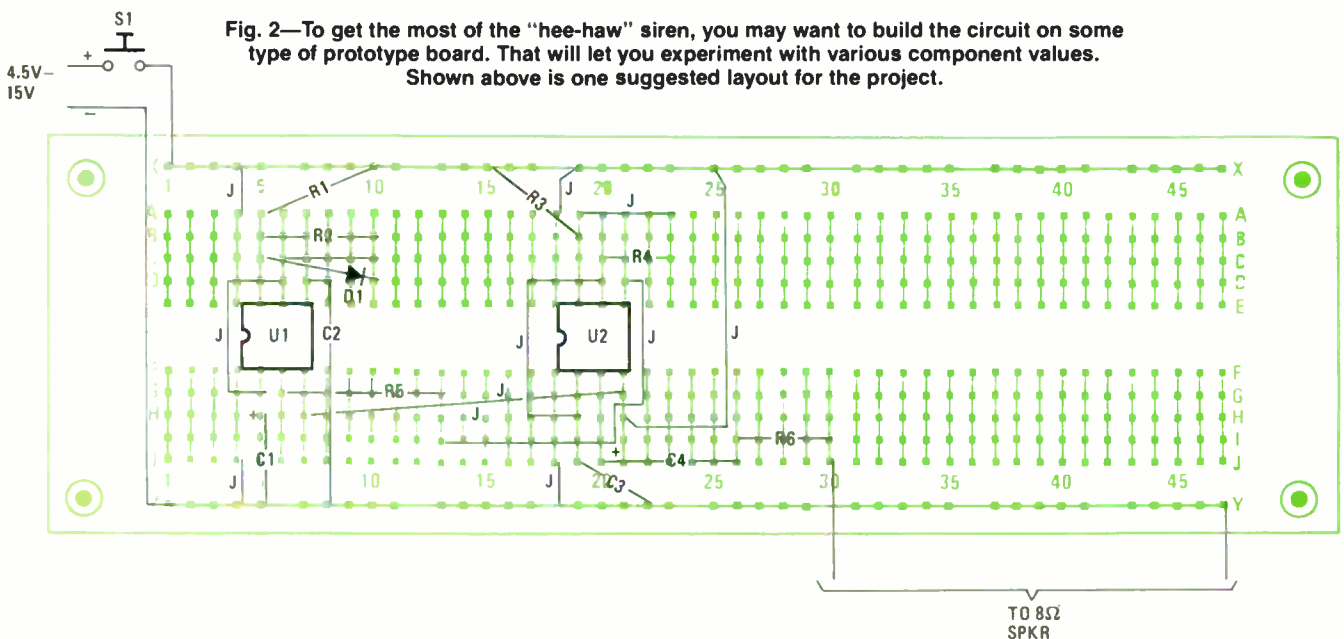

# DIGITAL FUNDAMENTALS

The first in a series of short courses to aid the electronics hobbyist and avid experimenter in understanding the digital theory used today in virtually all types of electronic equipment.

## LESSON 1: BINARY DATA

By L.E. Frenzel

□DIGITAL TECHNIQUES ARE THOSE SPECIAL ELECTRONIC methods that use on-off, pulse-type signals and logic circuits to process and communicate information. Digital methods are found in virtually all types of electronic equipment today. They are now so common, in fact, that they have become part of basic electronics fundamentals. This series of self-instructional lessons introduces the subject of digital techniques. It will show you how digital circuits operate.

What you can expect to learn in this article is: The difference between analog and digital methods; why digital methods are used; binary data representation; converting between binary and decimal numbers; understanding hexadecimal, BCD, and ASCII data; representing binary information with electronic signals and components; and exactly what is serial and parallel data. No, that is not too much information for one article. You have been exposed previously to much of that information, and, in some instances, you will recall prior information that will make this article tie many facts together consolidating your current knowledge.

### Electronic Applications

The three basic applications for electronics are **communications**, **computation**, and **control**.

In **communications**, we transmit information from one place to another by wires or radio techniques.

In **computation**, we process data. Numerical, text, and

other types of information are manipulated with mathematical or logic techniques to create new information. Computers, of course, are our data processors.

**Control** refers to automating industrial and other processes. That means using electronics methods to operate equipment remotely and/or automatically.

All three areas of electronics are well known and you can probably name numerous examples of each.

### Analog and Digital

There are two basic methods used in implementing electronic communications, computation, and control processes. And there are two basic methods of representing information. Those two methods are **analog** and **digital**. The terms analog and digital refer to the types of signals and circuits used in the electronics processes.

An **analog signal** is one that varies smoothly and continuously. Figure 1 shows several kinds of analog signals. A constant positive DC voltage level of 6 volts is illustrated in Fig. 1A. An alternating current (AC) signal known as a sine wave is shown in Fig. 1B. It has a peak value of  $\pm 3$  volts and a peak-to-peak value of 6 volts. A randomly varying analog signal is shown in Fig. 1C. Although the latter may appear to be random, it could be a track of temperature during a 24-hour period, a section of a voice signal, or the rise and fall of a local tide.

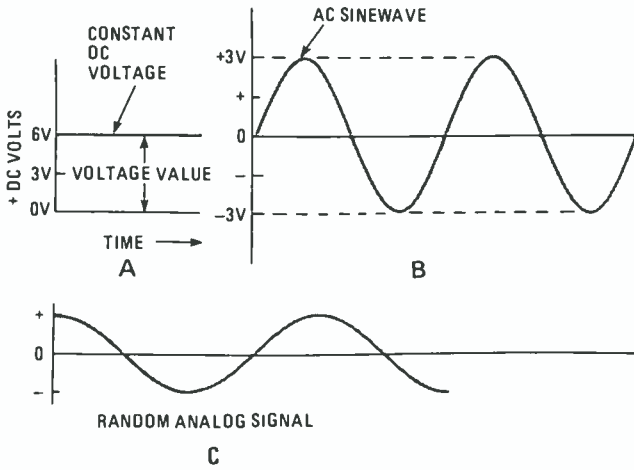

**Fig. 1—Three sample analog voltages: A, constant DC voltage typical of that produced by a voltage regulator circuit; B, sinewave signal typical of an unmodulated AM broadcast station of signal generator; and, C, random analog signal that may be the plot of a missile path, light intensity during a cloudy day, or just about any type of non-periodic event.**

The other type of electronics signal is a **digital** one. Instead of a smooth, continuous variation, a **digital signal** is made up of clearly defined discrete voltage or current levels with abrupt changes between them. The most common type of digital signal is the two-level or binary-pulse type signals shown in Fig. 2. In Fig. 2A, the signal switches between the 0 and +5 volt levels. In Fig. 2B, the two switched states are -12 and +12 volts.

While digital signals *can* have more than two discrete levels, typically they do not. The term **digital** is virtually synonymous with the term **binary** which implies **two (2)** levels.

### Representing Information

Digital and analog signals typically represent **information** to be communicated or processed. For example, the analog voice signal generated by a microphone might be modulated and transmitted by radio. Or the binary input from a keyboard may be processed by a digital computer to enter your savings deposit. Those signals, representing **information (data)**, are then processed to accomplish some useful end result. Analog signals are processed by **analog (linear) circuits**. Binary data is processed by **digital logic circuits**.

At one time, virtually all electronics signals and processes were analog. However, with the development of the digital computer, digital methods became more popular and widely used. Then, semiconductor technology gave us digital integrated circuits and the microprocessor, both of which have revolutionized electronics methods. Today, digital methods are preferred because of their ease of implementation, low-cost, reliability, and overall effectiveness. While digital techniques will never replace analog techniques **completely**, the use of digital techniques has grown continuously over the years and today virtually dominates in most electronics applications.

### Decimal verses Binary Numbers

The information or data to be communicated, processed,

or used for control purposes is usually numerical in nature. For that reason, the main language of digital techniques is numbers that can also be used to represent letters of the alphabet and even special control functions.

You are familiar with the **decimal number system** where we use the digits 0 through 9 in various combinations to represent any quantity. The decimal number system is based upon a method of giving numerical weights to each position or digit in the number. Recall that we usually refer to those positional weights as units, tens, hundreds, thousands, etc. Each position is a successively larger power of ten—10 to the 0 power =  $10^0 = 1$ ; 10 to the 1st power =  $10^1 = 10$ ; 10 to the 2nd power =  $10^2 = 100$ ; 10 to the 3rd power =  $10^3 = 1000$ ; etc. The simple illustration below shows how any decimal number is structured and evaluated.

Thousand	Hundreds	Tens	Units	
1	9	8	5	
$1 \times 1000 = 1000$	$9 \times 100 = 900$	$8 \times 10 = 80$	$5 \times 1 = 5$	
1,000	+	900	+	80
			+	5
<b>= 1985</b>				

In digital circuits, we use **binary numbers** rather than **decimal numbers**. In the **binary number system** only two digits, 0 and 1, are used. For example, the binary number 1010011 represents the decimal number 83. The digits 0 and 1 are called **binary digits** or **bits**. Like the decimal number system, the binary number system uses a positional or weighted method. Instead of weights of some power of 10, the position weights in the binary number are some power of 2. Thus we have: 2 to the 0 power =  $2^0 = 1$ ; 2 to the 1st power =  $2^1 = 2$ ; 2 to the 2nd power =  $2^2 = 4$ ; 2 to the 3rd power =  $2^3 = 8$ ; etc. Note that each successively higher weight is twice that of the preceding weight.

The structure of a typical binary number is shown below.

Weight	64	32	16	8	4	2	1
Number	1	0	1	0	0	1	1
	MSB					LSB	
<b>64 + 0 + 16 + 0 + 0 + 2 + 1 = 83</b>							

Notice that the binary number is usually made up of a number of bits; in that case, eight. Each bit may be binary 0 or binary 1. The weight of each position is indicated. Note particularly the **least significant bit (LSB)** with the lowest position weight and the **most significant bit (MSB)** with the highest position weight. The question is: How do you determine what decimal quantity is represented by a given binary number?

### Converting A Binary Number To Its Decimal Value

**Evaluating a binary number** means determining its **decimal value**. The process is similar to that used in evaluating any other decimal number. The illustration below shows what we mean.

Weight	32	16	8	4	2	1
Number	1	1	1	0	1	0
	$1 \times 32 = 32$	$1 \times 16 = 16$	$1 \times 8 = 8$	$0 \times 4 = 0$	$1 \times 2 = 2$	$0 \times 1 = 0$
<b>32 + 16 + 8 + 0 + 2 + 0 = 58</b>						

To determine the decimal value of a given binary number, all you do is multiply each bit by its position weight, then sum all of those values. Looking closely at the process above, you can see that those bit positions with a zero in them actually have no effect on the outcome. For that reason, they can be

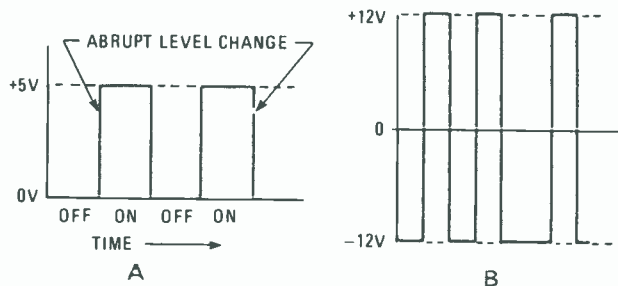

Fig. 2—Two commonly used digital signals in electronic circuits. The left one (A) is from a single-ended output such as from a 4000 chip series; and B, the output from a balanced op-amp that uses  $\pm 12$ -volts DC supplies.

ignored. You can quickly evaluate the binary number simply adding up the weights of those positions that contain a binary 1 bit. The secret is in remembering the weight in each position, and that's easy.

### Converting A Decimal Number Into Its Binary Equivalent

Another procedure that you will find handy is that for converting a decimal number into its binary equivalent. The process is essentially that of dividing the original number by two, then dividing the resulting quotient by two continuously until a quotient of zero is obtained. The remainders resulting from each of those divisions form the binary number. An example given below shows how to convert the decimal number 84 into a binary number.

<b>Division</b>	<b>Remainder</b>	
$84 \div 2 = 42$	<b>0 LSB</b>	
$42 \div 2 = 21$	<b>0</b>	
$21 \div 2 = 10$	<b>1</b>	
$10 \div 2 = 5$	<b>0</b>	Therefore, 84 = <b>1010100</b>
$5 \div 2 = 2$	<b>1</b>	
$2 \div 2 = 1$	<b>0</b>	
$1 \div 2 = 0$	<b>1 MSB</b>	

### Maximum Decimal Value

A binary number, or binary word as it is sometimes called, usually consists of a fixed number of **bits** when used within one confined system. With that number of bits you can represent a certain maximum value. The same is true of decimal numbers. With a given number of digits, some maximum value can be represented. For example, with four digits, the **maximum decimal value** is 9999. With a 4-bit binary number, the maximum value is 1111. The question is: What's the maximum decimal value for a given number of binary bits? That value can be computed using the simple formula shown below.

$$M = 2^n - 1$$

Where M is the maximum decimal value and n is the number of bits. To illustrate the use of that formula, let's determine the maximum decimal value you can represent with 4 bits. That is done as shown below.

$$M = 2^4 - 1 = (2 \times 2 \times 2 \times 2) - 1 = 16 - 1 = 15$$

Fig. 3 shows all possible combinations of a 4-bit word with their decimal equivalents. There are sixteen values, 0 through the maximum 15. Remember that 0 (zero) is a number and it is one of 16 values in a 4-bit binary number.

<b>Decimal</b>	<b>Binary</b>	<b>Decimal</b>	<b>Binary</b>
0	0000	8	1000
1	0001	9	1001
2	0010	10	1010
3	0011	11	1011
4	0100	12	1100
5	0101	13	1101
6	0110	14	1110
7	0111	15	1111

Fig. 3—The decimal/binary equivalents are listed here for the first 16 numbers. Keep in mind that 0 (zero) is a number.

Eight bits is a very common binary word size. With 8 bits, you can represent decimal values up to  $2^8 - 1 = 255$ . 8-bit words or numbers are so widely used that they have been given a special name. An 8-bit binary number or word is called a **byte**. You will also hear the term **nibble** to refer to 4-bit words.

### Hexadecimal Notation

To represent larger and larger decimal values, binary numbers with more bits must be used. And, as the binary numbers get larger, they become increasingly difficult to work with. For example, it takes 20 bits to represent numbers up to one million, 1,048,576 to be exact. It's tough enough to remember a long decimal number, but just imagine the problem of remembering a very long binary number.

That task is made easier by the use of a special shorthand known as **hexadecimal notation** that consists of **hexadecimal numbers**. Hex means *six* and, of course, decimal means *ten*; therefore, hexadecimal means *sixteen*. Hexadecimal refers to a special notation as well as a number system using a total of 16 digits. Those digits are the decimal numbers 0 through 9, and the letters A through F. Each digit corresponds to its equivalent 4-bit binary code as shown in Fig. 4. The idea is to use the hex digit corresponding to each 4-bit segment of a long binary number. The result is a shorter hexadecimal number that is far easier to remember and to apply.

To convert a binary number into hexadecimal number, all you do is divide the long binary number into 4-bit segments starting with the LSB on the far right. Then, replace each of those 4-bit segments with the corresponding hex digit from Figure 4. The result is illustrated below.

1011 0001/0111 0010 1101  
**B 1 7 2 D**

Changing a hexadecimal number back into its binary equivalent is also easy. You simply reverse the above process.

<b>Hexadecimal</b>	<b>Binary</b>	<b>Hexadecimal</b>	<b>Binary</b>
0	0000	8	1000
1	0001	9	1001
2	0010	A	1010
3	0011	B	1011
4	0100	C	1100
5	0101	D	1101
6	0110	E	1110
7	0111	F	1111

Fig. 4—The hexadecimal/binary equivalents are listed here for the first 16 numbers. Compare this illustration to that of Fig. 3. When you use the hexadecimal number system for a short while, you will begin to appreciate the convenience of the system.

Simply replace each hexadecimal digit with its binary equivalent and string all of the resulting bits together as shown below.

6 F 9 0 5  
0110/1111/1001/0000/0101

### BCD

Besides the standard binary notation for representing a decimal number, some special variations are also widely used. The most common is **binary coded decimal (BCD)**. The BCD system is essentially a hybrid of both the binary and decimal systems. It uses binary digits, but a separate four-bit group is used to represent each decimal digit individually. The BCD code is the same as the first ten digits (0 to 9) of the hexadecimal code in Fig. 4.

To represent a given binary coded decimal value, you simply use the 4-bit group representing each digit. An example is given below using the decimal number 4891.

4 8 9 1  
0100 1000 1001 0001

A space is left between each 4-bit group to denote separate digits.

BCD is a widely used method as it greatly simplifies the conversion process between binary and decimal. It is also an aid in improving communications between man and machine. Where a human operator must interface with a piece of digital equipment, BCD is normally employed. Keyboards generally produce BCD outputs. BCD information from a piece of electronic equipment is normally used in 7-segment decimal displays that are so popular.

### ASCII

A special form of BCD is widely used in computers. Known as the **American Standard Code of Information Interchange (ASCII)**, pronounced *ass-key*, it normally uses 7-bits to represent not only the decimal digits 0 through 9, but also letters of the alphabet (both upper and lower case), punctuation marks, and special symbols. Some examples of ASCII designations are shown below.

8 = 011 1000 (Last 4-bits same as BCD)  
L = 100 1100  
J = 110 1010  
? = 011 1111  
Bell = 000 0111 (This code rings a bell or sounds a tone.)

The ASCII code is widely used in computers. It is the main code used in communicating information between computers and peripheral devices. For example, virtually all printers produce hard copy output from ASCII input supplied by the computer. ASCII coded data is also what is normally transmitted and received by a modem in digital communications.

### Representing Binary Numbers with Hardware

The reason for using the binary number system in digital equipment is that it is easier to implement binary electronic circuits than it is decimal circuits. Decimal circuits would have to represent at least ten states. With binary, only two states are required. As a result, any electronic component that can assume two states can be used for binary representation. The result is smaller, simpler, cheaper and faster circuits.

The most obvious component to represent a bit is a switch. A switch can be *off* or *on*; and, therefore, can represent 0 and

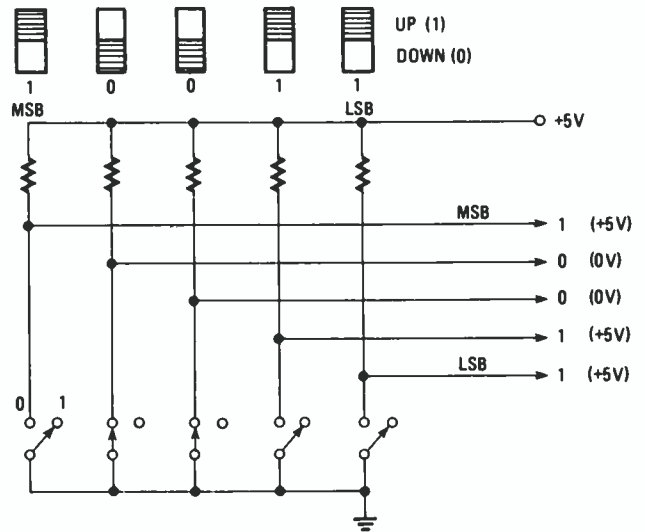

Fig. 5—A simple manual switching circuit can be constructed and used to demonstrate (or actually be used to input a computer device) binary data for decimal numbers 0 to 31.

1. Fig. 5 shows how a group of slide switches is used to produce binary data. The number being displayed on those switches is 10011, whose decimal equivalent is 19. The illustration also shows what the schematic diagram may look like. When the switch slide is down, it is closed. The voltage at the output, therefore, is 0 volt or at ground potential. That typically represents a binary 0 (in some discussions it is referred to as a logic low). When the switch is up, it is open. As a result, the output is +5 volts as seen through the resistor. That represents a binary 1 (or a logic high).

Another obvious choice of a component to represent binary data is a simple *light*. Both incandescent lamps and **light-emitting diodes (LED's)** are used to display binary information. An off (unlit) display represents a binary 0, while an on (lit) display represents a binary 1. The set of lights in Fig. 6 show how a typical binary lamp display might look.

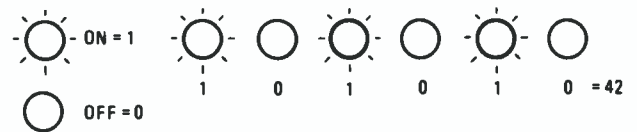

Fig. 6—A six-unit, light-emitting diode (LED) display aligned in a row can be used to display binary data for decimal numbers from 0 to 63. Most significant bit is at the display left side.

In electronic circuits binary digits are represented by electronic components and circuits. Of course, the key component in any electronic circuit is the transistor, discrete or integrated. A transistor as used in digital circuits is a switch. A transistor can be on (conducting). Alternately, it can be off (non-conducting). Those are natural conditions representing binary 0 and binary 1 states. Both bipolar and MOS FET's are used in digital circuits. See Fig. 7.



Fig. 7—Two of several transistor types used in binary circuits.

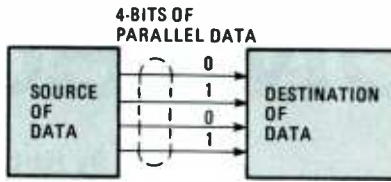

Fig. 8—4-bits of parallel data transmitted from a circuit like that in Fig. 5 are transmitted over four lines at the same time to a destination which could be another chip on the same circuit board, a remote printer, or some other device.

### Parallel and Serial Data

Binary data in digital circuits is generated, processed, displayed, or communicated. There are two ways in which those things are done: **Parallel** and **serial**. **Parallel binary data** is where all bits of a word are generated, processed, transmitted or displayed simultaneously. The data generated by the switches in Fig. 5 and that displayed in Fig. 6 are both examples of parallel binary data. All bits of the word occur at the same time and can be transmitted from one place to another as shown in Fig. 8.

The other form of binary data is serial. **Serial binary data** is transmitted or processed one bit at a time. The bits occur sequentially and, therefore, each is handled separately in order. A serial data word is shown in Fig. 9. The binary 0's and 1's are represented by voltage levels. Note that each bit occurs for a fixed length of time. If each bit lasts one millisecond, then it will take a total of 8 milliseconds to transmit or process one byte.

As you can see, the main disadvantage of serial data is the

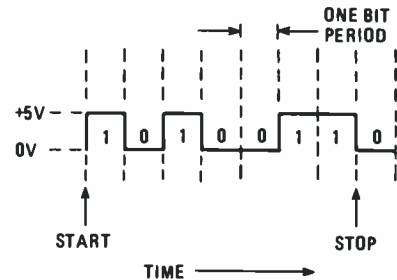

Fig. 9—An 8-bit serial binary word displayed against time.

long time required to transmit or process it. On the other hand, serial data is far less expensive to deal with. Only one set of processing circuits are required, and only a single line, rather than multiple lines is required to transmit it from one place to another. Despite its low-speed disadvantage, serial data is widely used. It is perfectly suitable for many digital applications.

### Check Yourself Out

You are urged to complete the Short Quiz we have provided. It will assist you in reviewing the key facts that were presented here. Answering the questions will allow you to apply what you have learned so as to reinforce your knowledge. The answers are given in smaller type, and upside down under the quiz.

There will be more articles like that on continuing in stages to progress the development of your knowledge. Should you like what you see here, please let us know. Your comments are valuable, or should we say, "Your *inputs* are valuable." ■

### SHORT QUIZ ON DIGITAL FUNDAMENTALS

- The three primary electronics applications are \_\_\_\_\_, \_\_\_\_\_, and \_\_\_\_\_.
- a. Smooth, continuous signals are called \_\_\_\_\_.
- b. Digital signals usually have \_\_\_\_\_ (how many?) levels.



- Refer to the LED binary display above. What decimal number is represented? \_\_\_\_\_
- a. If binary 0 = 0 volt and binary 1 = +6 volt, write the binary output voltage levels equivalent to the decimal number 207. MSB \_\_\_\_\_, \_\_\_\_\_, \_\_\_\_\_, \_\_\_\_\_, \_\_\_\_\_, \_\_\_\_\_, \_\_\_\_\_, \_\_\_\_\_ LSB.

- The above decimal number expressed as a hexadecimal number is \_\_\_\_\_.
- An eight-bit binary number is called a \_\_\_\_\_.
- Write the BCD equivalent of the number 2805. \_\_\_\_\_
- The special code used to transmit letters as well as numbers is called \_\_\_\_\_.
- The maximum decimal value you can represent with 12 bits is \_\_\_\_\_.
- Binary numbers are represented in electronic circuits by \_\_\_\_\_ and \_\_\_\_\_.
- Which method of processing and transmission of binary data is slower?  
\_\_\_\_\_ parallel \_\_\_\_\_ serial.

- ASCII
- 4095; 2<sup>12</sup> - 1 = 4095
- bipolar and MOS transistors
- serial

- communications, computer, control
- a. analog; b. two
- 10101001 (binary) = 169 (decimal)
- a. MSB + 6, + 6, + 6, + 6, + 6, + 6, + 6, + 6, 0, 0
- b. CF
- 11001111;
- 6, + 6, + 6, + 6, + 6, + 6, + 6, + 6, 0, 0
- 6, 0010 1000 0000 0101

ANSWERS TO QUIZ

# JUNK BOX

By Herb Friedman

the home computer TV displays are anything to write home about.

But if you have a TI44/A stored in the closest gathering dust, or know of one lying around in someone's junkbox you can salvage the TI (Texas Instruments) modulator and make it into a very good universal RF modulator that's suitable for use with any computer, even an IBM PC.

The TI modulator shown in the photographs is a complete integrated package consisting of the TV transmitter, a harmonic filter (which is what filters the interference before it gets into the TV set), and a switching unit that simultaneously switches the TV set between the antenna and the RF modulator, and controls the modulator's power. The power to the TI modulator is automatically switched off when the selector switch connects the TV set to the antenna.

All that's needed to use the TI modulator with any other computer is a suitable power supply which you probably can build using most junkbox parts, and some way to convert the DIN plug input of the TI modulator to a phone jack, which is now, more or less, the standard composite video connector for personal computers.

Both the power supply and the phono-to-DIN conversion can be built in a small plastic cabinet, such as the model shown in the photographs. While the TI modulator will work off an unregulated power source of approximately 11-12-volts DC, it's easier to build a well-filtered power supply of the proper rating, using a three-terminal voltage regulator.

## Construction

The power supply is built in a  $4\frac{1}{4}$  -  $\times$   $1\frac{1}{4}$  -  $\times$   $2\frac{7}{8}$ -in. plastic Unibox cabinet. The layout isn't critical. The circuit can be assembled on a small piece of perforated wiring board cut to fit inside the box. The components aren't secured to terminals

This is how the TI modulator looks with the top cover removed. The power and video connections enter the compartment at the upper left. The compartment at the lower right contains a low-pass filter for the RF oscillator (TV transmitter).



□ ONE OF THE FIRST THINGS DISCOVERED WHEN A HOME OR family computer is replaced by an *office* computer is that the TV set that was used as the computer monitor won't work with the new machine. The new computer has a video-output jack rather than a TV signal on Channel 3 or 4. While no one in his or her right mind would suggest using a TV set as an *office* monitor, sometimes the budget won't yet stretch for a standard color monitor. Also, you just don't want to take the color monitor along if you take the computer out of the house—say to give a demonstration at your school or club. While you have splurged for an office computer, you still might have need to use your TV monitor from time to time.

But to use a TV set for a monitor you'll need an RF modulator, a device that transmits the computer's output on TV channel 3 or 4. While several commercial RF modulators specifically intended for that purpose are available, they are not known for creating quality screen displays. In fact, except for the RF modulator from the TI44/A home computer which produces a razor-sharp, interference-free TV display, none of

The RF modulator from the TI44/A home computer is a separate modular unit that also contains the antenna/computer switching. It is easily adapted to computers having a conventional video output. The device is referred to as the TI modulator in text.

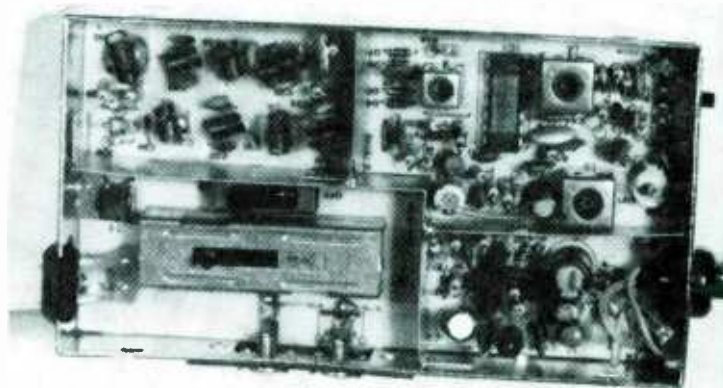



# RF MODULATOR

**An inexpensive home-built device that can run a home TV as a color monitor!**

or tie points: instead, their leads and wires are passed through the holes in the board, twisted (if necessary) under the board, and soldered. However, since some components might end up with a slight amount of looseness of fit, take extra care that they cannot short-circuit if the box is moved violently. Not only must every connection be soldered: the component itself must be secured to the perfboard.

The TI modulator requires nominally 11.5 volts at a little less than 50-mA, so just about any 12-volt transformer can be used for T1. See Fig. 1. The transformer used is a small 12-volt, 300-mA, untapped filament transformer. If transformer T1 has a center-tap, tape it up. Any bridge rectifier rated 25V PIV or higher may be used for BR1. Both the electrolytic and Mylar capacitors can be rated at 16-WVDC.

The power-on indicator is a red light-emitting diode (LED1) which came from a 20-for-\$1.00 kit. It is mounted using its original stiff leads so it will poke through a hole in the front of the cabinet. A diffused-lens LED is recommended because it's more easily observed through a relatively wide viewing angle.

Do not eliminate the LED POWER indicator even though there is an LED indicator in the TI modulator. The TI modulator's LED indicates an overload condition, not power; under normal conditions it will always be off.

Completely assemble the power supply, including the line-cord, and secure it to the base of the cabinet. Install the DIN (J2) and phono (J1) connectors on the cover, and using the shortest possible lengths of ordinary insulated wire—not shielded cable—connect the video and video ground wires from J1 to J2. Make certain that those wires cannot short to adjacent DIN terminals. Then determine the minimum length of the wires needed to reach from the power supply to the DIN connector and install them between the power supply's output and the DIN connector.

Take particular note that there are separate power and video ground wires in the TI modulator's connecting cable. To avoid ground loop signals that might interfere with the normal operation of the Junkbox RF Modulator, don't mix the grounds in the power supply—keep them separate. They will be automatically connected together within the TI modulator.

**Fig. 1—Schematic diagram for the power supply used with the Junkbox RF Modulator. Wiring for DIN jack J2 is viewed from cable side of connector. Watch LED1 and other polarized parts.**

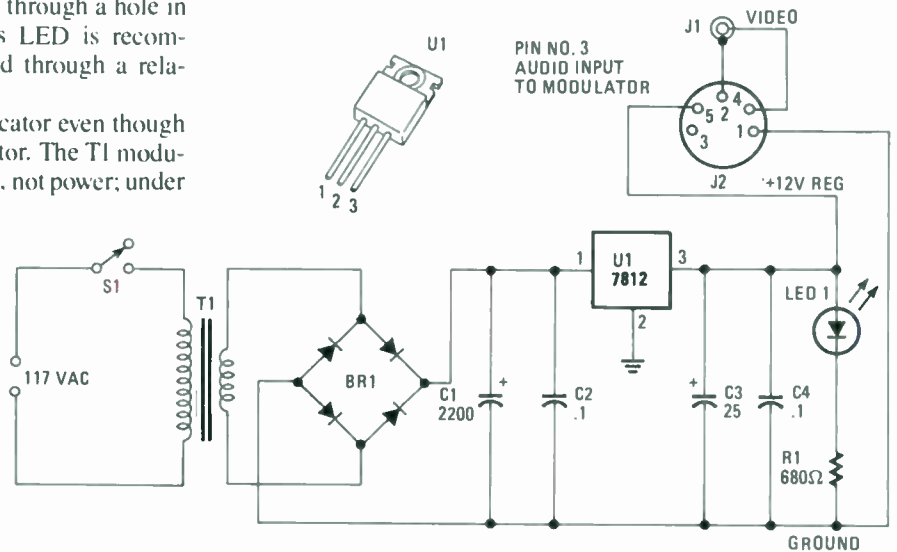

The pointer is resting on the top lead of resistor R32, the one to cut when the TI modulator needs more drive. That resistor is located directly under the center conductor of the shielded video wire. Note the PC board "R32" marking.

The power supply can be assembled on a small scrap of perf-board. Component mounting terminals (flea clips) aren't needed. Instead, the component's leads can be passed through the perf-board and twisted together before soldering.

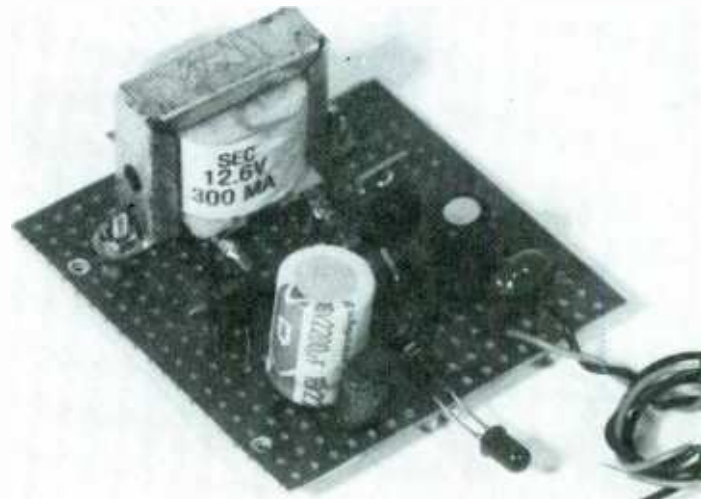
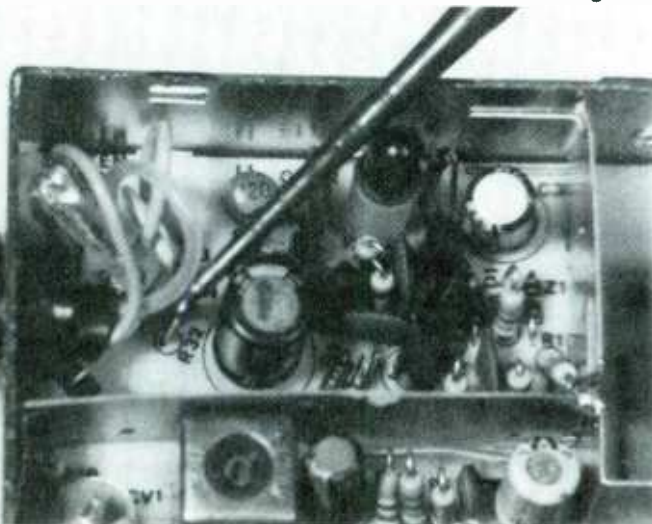

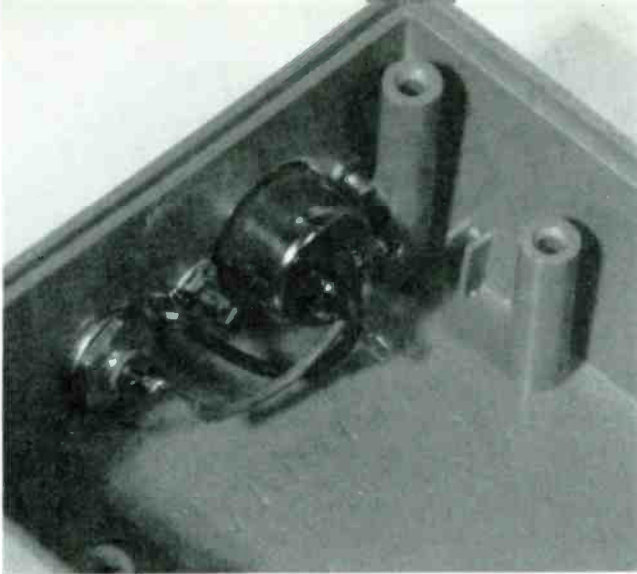

The DIN socket (J2) and the phono jack (J1) for the video are mounted in the cabinet's cover. Wire the phono to DIN video connections before installing the wires from the power supply.

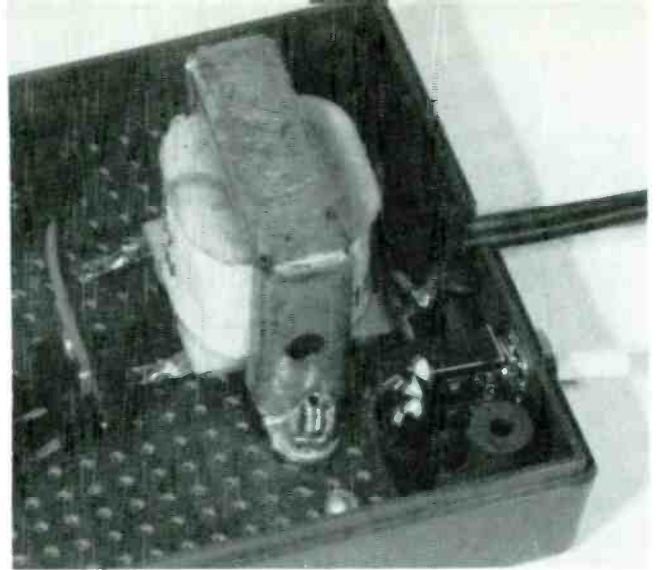

A miniature, power, toggle switch, S1, can be installed in the bottom of the plastic cabinet. If you need extra room, cut a small notch from the perforated wiring board. Plan ahead!

As far as you are concerned, the power and video connections at the power supply's DIN jack are completely independent.

If all of the DIN socket terminals have a connection, there is a wiring error.

### Checkout

Test the power supply and the DIN/phono connections before you connect the Junkbox RF Modulator—you might not get a second chance if you have made a wiring error. Make certain that the power supply is 12-volts DC. If your meter reads anything else, such as 16-19 volts there is something wrong with the connections to voltage regulator U1, or the device is defective.

Then, with your voltmeter's ground lead connected to the DIN socket's power-supply ground terminal, make sure that there is no voltage reading at the terminals used for the video and video ground. You can make the checks at the phono jack's terminals.

### Using the RF Modulator

Connect the Junkbox RF Modulator to the 300-ohm VHF antenna terminals on the back of your TV set and set the TV set's channel-selector to either channel 3 or channel 4—the one not used in your locality. Similarly, set the small channel selector switch on the cable end of the Junkbox RF Modulator to the same channel as the TV set. Finally, set the antenna selector to MODULATOR and make certain that it is firmly seated, because the selector also operates an internal power switch that clicks in at the extreme end of the antenna selector's motion. Similarly, when moving the selector the opposite way so the TV set is connected to the TV antenna,

make certain that the selector is seated at the opposite end so that the project's internal power switch is turned off.

Next, connect the TI modulator's power cable to the power supply. Using a low-capacity shielded or coaxial cable, connect the computer's composite-video output jack to the video phono jack on the power supply. Then turn the power supply on and keep an eye on the television screen.

*(Continued on page 97)*

### PARTS LIST FOR JUNKBOX FM MODULATOR

#### SEMICONDUCTORS

- BR1—Bridge rectifier, rated at 25-PIV, or higher
- LED1—Light-emitting diode, 20-mA, red, diffused lens
- U1—7812 12-volt regulator

#### CAPACITORS

- (All capacitors are rated 16-WVDC or higher)
- C1—2200- $\mu$ F, electrolytic
- C2, C4—0.1- $\mu$ F, Mylar
- C3—25- $\mu$ F, electrolytic

#### ADDITIONAL PARTS AND MATERIALS

- J1—RCA Phono jack
- J2—5-terminal, DIN, chassis-mount jack
- R1—680-ohm, 1/2-watt, 10% resistor
- S1—SPST, miniature, toggle switch
- T1—12.6-volt filament transformer, see text
- Perfboard, plastic cabinet, molded AC plug on power-cord, hardware, wire, solder, etc.

Finally, connect the power supply's wires to DIN connector J2. Leave a little extra slack so that the wires aren't stressed when the plastic cabinet is closed up.

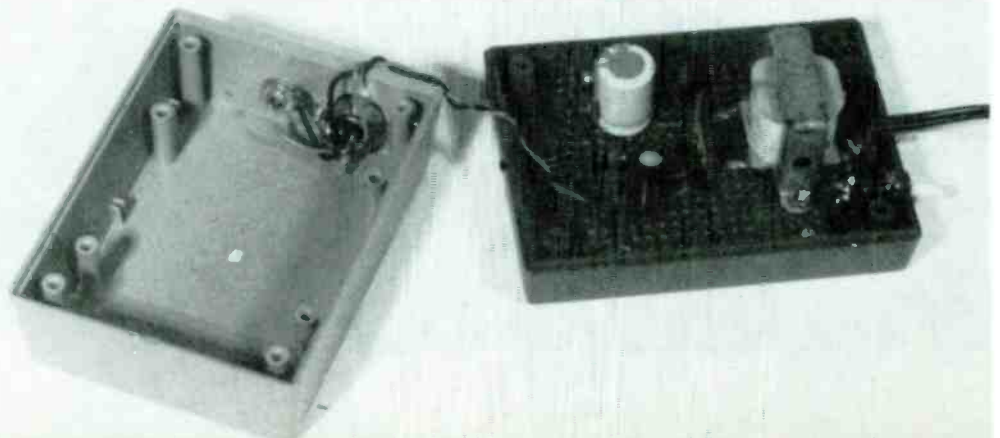

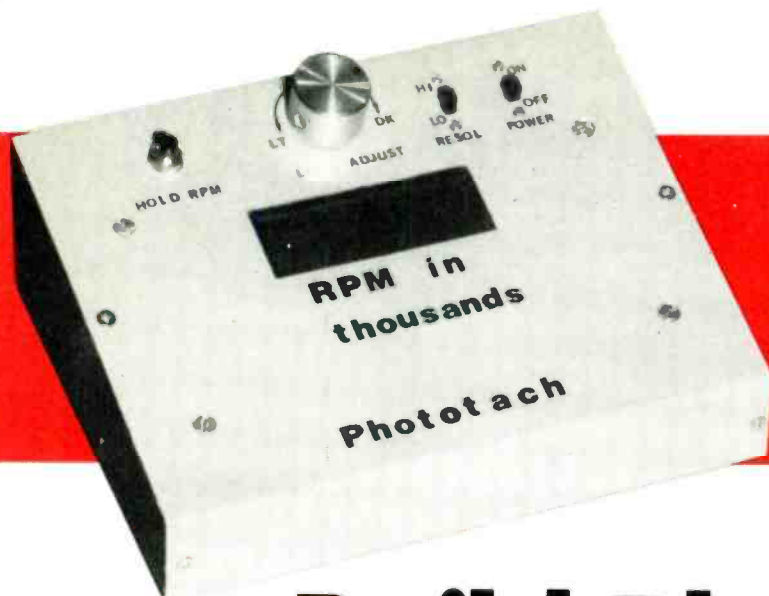

Why spend \$300 or more on a phototachometer when you can build this unit for less than \$70? It is easy to build, easy to adjust, and even easier to use!

# Build PhotoTach

By W.N. Hubin\*

ALTHOUGH IT HAS MANY MORE APPLICATIONS, PHOTOtach evolved from an urgent need to accurately measure the maximum propeller *rpm* (revolutions per minute) of an experimental aircraft. That *rpm* was the sole indicator of engine output, but the tachometer used to measure it was suffering from vibration-induced fatigue and its readings were more than a little suspect. Another important use for Phototach has been the calibration of commercial mechanical tachometers used on certificated aircraft. That calibration is particularly critical for aerobatic aircraft that commonly have a narrow range of propeller speeds that must not be used because of propeller/engine resonances.

You may still be asking what a phototachometer is. Well, it's not a device to measure how fast you can take photographs! A phototachometer (and the Phototach) can be used for the precise measurement of the frequency of any periodically varying light source—that light can be either reflected or emitted. Phototach is easily adapted to measuring a varying voltage originating from sources other than a light source, as will be discussed later.

While commercial digital phototachometers will set you back about three hundred dollars, Phototach can be built for about seventy dollars from readily available components. It features two measuring ranges, a maximum count of 19999, crystal-based precision, and a large 0.75-inch liquid-crystal display for fine readability in the brightest sunlight. It is usable over a wide range of light intensities, and its power requirements are extremely modest. Phototach draws about 9.5 milliamperes from a 9-volt transistor-radio-type battery. That means that even a standard battery will give about 50 hours of use. Calibration is easily accomplished with the help of a fluorescent light.

\*Professor, Kent State University

## Light Pulses to Counts

Because it is inherently a digital measurement, Phototach will provide just as much accuracy as one wishes to wait for, unaffected by the electrical and mechanical gremlins that plague normal tachometers. The common two-bladed propeller interrupts the light from a source between you and it exactly two times for every complete revolution. To obtain the average number of revolutions per minute ( $\pm 1$  rpm) we would count those interruptions for a period of one-half minute, or 30 seconds. However, if we are willing to settle for  $\pm 10$ -rpm precision, we need count light interruptions for only 3 seconds; for  $\pm 100$ -rpm precision we need count for only 0.3 second.

Phototach is based on an LSI integrated circuit that combines a 4½-digit counter with all the drivers needed for a full liquid-crystal display of the count. The supporting IC's condition the signal from the phototransistor used as a sensor, provide a precisely-timed gating signal for the counter, transfer the count to the display at the proper time, and then reset the counter for the next timed interval.

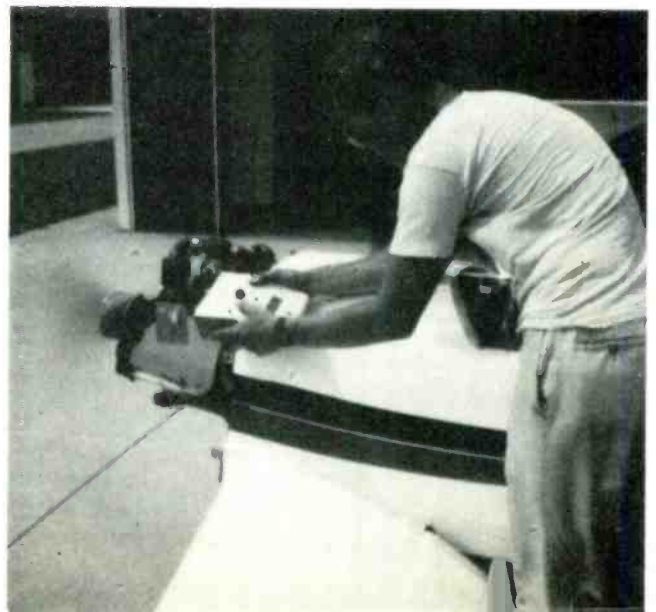

In the darkness of a hanger, the author uses Phototach to count the number of times the propeller blade interrupts the light coming through the open hanger door.

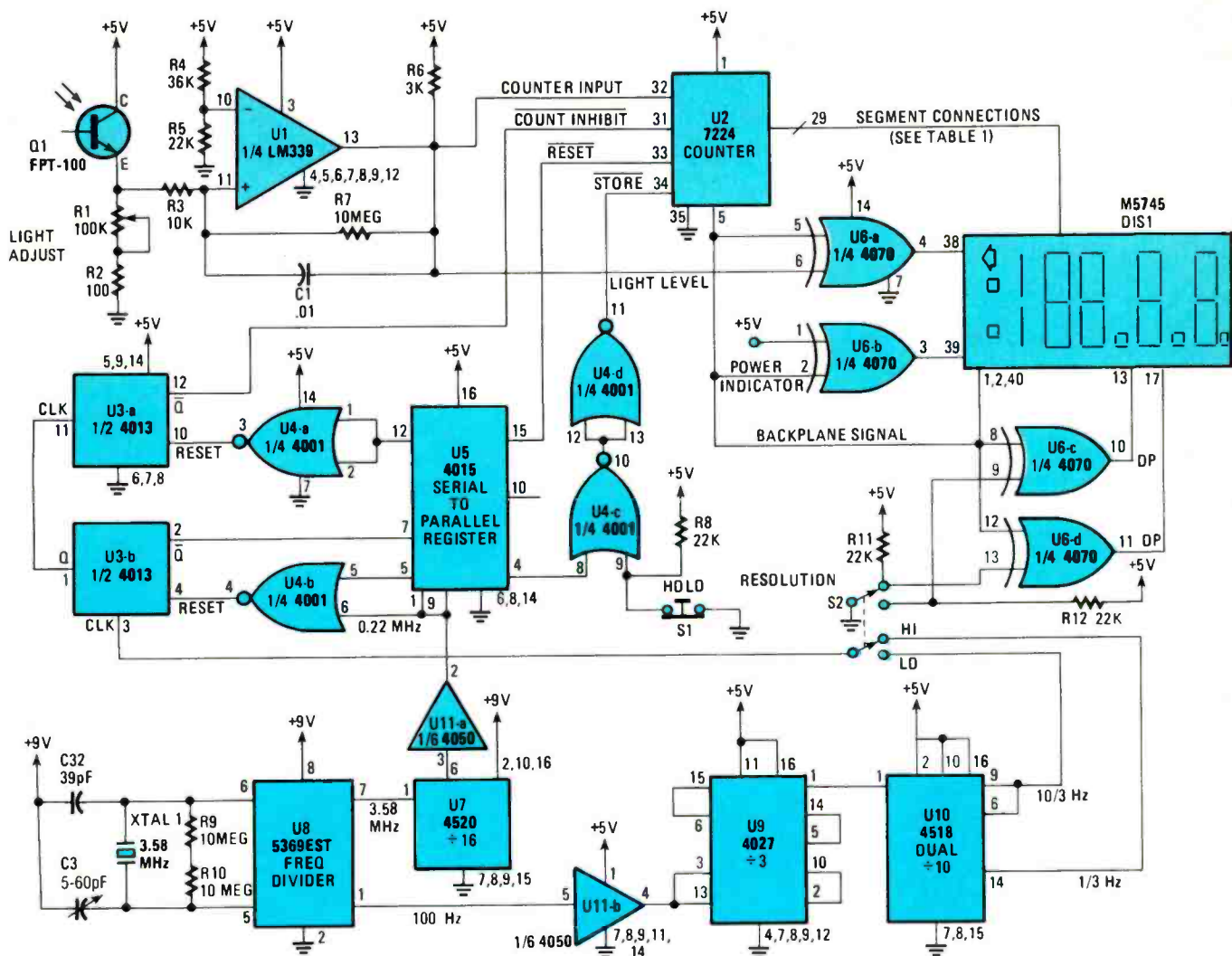

Fig. 1—Schematic diagram for the phototachometer. For simplicity, the 29 connections between U2, the 7224 counter/driver, and the display have been omitted. Those can be found in Table 1.

### Inside the Circuit

Looking more closely at the circuit, the LIGHT-ADJUST potentiometer, R1, in Fig. 1, permits the non-inverting input of comparator U1 to alternately go above and below the reference voltage of about 1.3 volts at the inverting input as the light source alternates in brightness. Capacitor C1 and resistor R7 provide the necessary hysteresis to ensure that the output of the comparator is a clean digital squarewave to the high-speed counters of U2.

Frequency divider U8 uses a standard TV crystal to produce a 100-Hz squarewave as well as a buffered 3.58-MHz output. (Note that U8 is a 5369EST rather than the more common 5369N. If a 5369N, which generates a 60-Hz output, is used, then U9 and U10 must be replaced with a divide-by-6 counter, a divide-by-3 counter, and a divide-by-10 counter.) The 100-Hz signal is further divided down to  $10/3$  Hz and  $1/3$  Hz by U9 and U10; the 0.3 second and 3.0 second durations of those signals is used to gate the counters off and on for low and high resolution respectively. Shortly after the counters are gated off, the count is transferred to the display, the counters are reset, and the counters are re-enabled by a 0.22-MHz signal derived from the 3.58-MHz signal by U7.

That last step is needed because U2 requires signals that are at least 3 microseconds in duration.

A serial-to-parallel register, U5, generates the timing pulses for U2 from a low logic-level that appears on its input as a result of the output of U3-b changing state: as that logic low is shifted down the register, it successively returns its input to a high logic-level through U4-b, sends a negative store pulse to U2 through U4-c and U4-d, sends a negative reset pulse directly to U2, and re-enables the counters through U4-a and U3-a. The timing diagram for that is shown in Fig. 2.

Switch S1, a normally-closed pushbutton switch, can prevent a store pulse from reaching U2 and therefore it is used to hold a frequency reading in the display while the phototachometer is moved away from the alternating light source.

Liquid-crystal displays must be fed a symmetrical AC voltage (equal on and off times) if they are to enjoy a long and happy life! Counter U2 is designed to do that for the individual segments of the display and EXCLUSIVE-OR gates U6-a, -b, -c, and -d do it for the left colon (as a power-on indicator), for the left arrow (as an indicator of sufficient light), for the second decimal point from the right (for the high resolution switch position), and for the first decimal point (for low

**Table 1—  
Wiring List IC2 To DISP1**

Segment	V2—7224 Pin Number	DISP1—M5745 Pin Number
A1	37	22
B1	38	21
C1	39	20
D1	40	19
E1	2	18
F1	4	23
G1	3	24
A2	6	26
B2	7	25
C2	8	16
D2	9	15
E2	10	14
F2	12	27
G2	11	28
A3	13	31
B3	14	30
C3	15	11
D3	16	10
E3	17	9
F3	19	32
G3	18	33
A4	20	35
B4	21	34
C4	22	7
D4	23	6
E4	24	5
F4	26	36
G4	25	37
1/2 digit	27	3
Backplane	5	1,2,4,8, 12,29,40

resolution), respectively.

Turning to the battery-based power supply (see Fig. 3), U12 is a standard 7805 (340T-5) three-terminal, voltage regulator that provides the supply voltages for all but U8 and U7. Because CMOS technology does not generate the large switching currents that TTL does, capacitors C4 and C5 provide adequate charge reserve. Capacitor C4 is placed physically close to the regulator, and C5 should be located where power is routed into the main board.

### Construction and Checkout

The prototype was built on a perforated board using wire-wrap, which is particularly appropriate for this project because of the small number of discrete components. The leads of the resistors, capacitors, and the crystal were pushed through the perfboard, wire-wrapped, and then soldered. A DIP jumper to a wire-wrap socket was used to bring power, the RESOL and HOLD switch connections, and the phototransistor signal to the perfboard. That construction technique permitted the perfboard to be completely detachable from the case. The liquid-crystal display, which comes with standard 0.1-inch pin spacing, is mounted by cutting a 40-pin wire-wrap socket down the middle (to get the greater width required by the display) and then spacing the socket halves about 1/4-inch away from the perfboard with a firm foam (to provide clearance from the box for the IC's).

The phototransistor, Q1, should be mounted at the front of the case but at the rear of a black tube so that only a narrow beam of light directly ahead of the phototachometer is sampled. We chose a 1/2-inch length of 5/32-inch diameter black spaghetti tubing, drilled a hole of that diameter in the

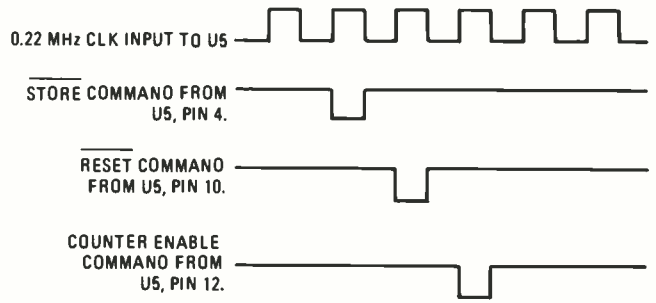

**Fig. 2—**This timing diagram shows the sequence of events that occur as a logic low is shifted down the U5 register. First the STORE pulse is sent to U2 via U4-c and U4-d, then the RESET pulse is sent directly to U2, and finally, the counters are re-enabled via U4-a and U3-a.

case, and mounted the front of the tube flush with the outside of the case with epoxy.

Refer to Table 1 for the wiring connections between U2 and the display. Also, as a check, verify that all the pins on the IC's have a wire connection to them except for pins 1, 2, and 14 of U1; pins 28, 29, and 30 of U2; pin 13 of U3; pins 2, 3, 11, and 13 of U5; pins 3, 4, 5, 11, 12, 13, and 14 of U7; pins 3 and 4 of U8; pins 3, 4, 5, 11, 12, and 13 of U10, and pins 6, 10, 12, 13, 15, and 16 of U11.

After verifying the proper operation of the power supply, troubleshooting of the completed circuit is conveniently done with a logic probe. If the comparator and the phototransistor are correctly wired, it should be possible to make comparator U1 switch states while pointing at a light fixture by varying the LIGHT-ADJUST potentiometer, R1. The operation of the timing circuit can be checked by looking for the 1/3- and the 1/3-Hz outputs from U10, as well as the 0.22-MHz input to the U5 clock, pins 1 and 9. The logic probe should show a predominantly high logic-level on the COUNTER INHIBIT input (pin 31), the RESET input (pin 33), and the STORE input (pin 34) of U2, but a very short low-logic pulse should also be detected at those inputs every 0.3 second or 3.0 seconds, depending on the position of the resolution (RESOL) switch.

### Calibration and Use

Phototach is conveniently calibrated by placing it on a bench so that the phototransistor is pointing upward at an overhead fluorescent light. The fluorescent light receives a maximum voltage from the AC power supply just twice in every cycle of the 60-Hz power, so in 3.0 seconds the counter should count to 360 with near perfect reproducibility. Capaci-

**Fig. 3—**The battery-based power supply for Phototach. Should the battery be installed outside the cabinet, no power switch (S3) is required. Otherwise, install one!

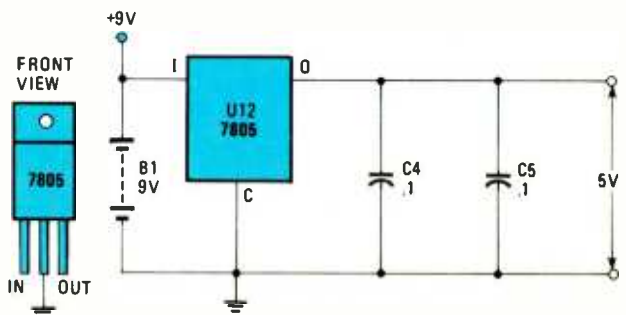

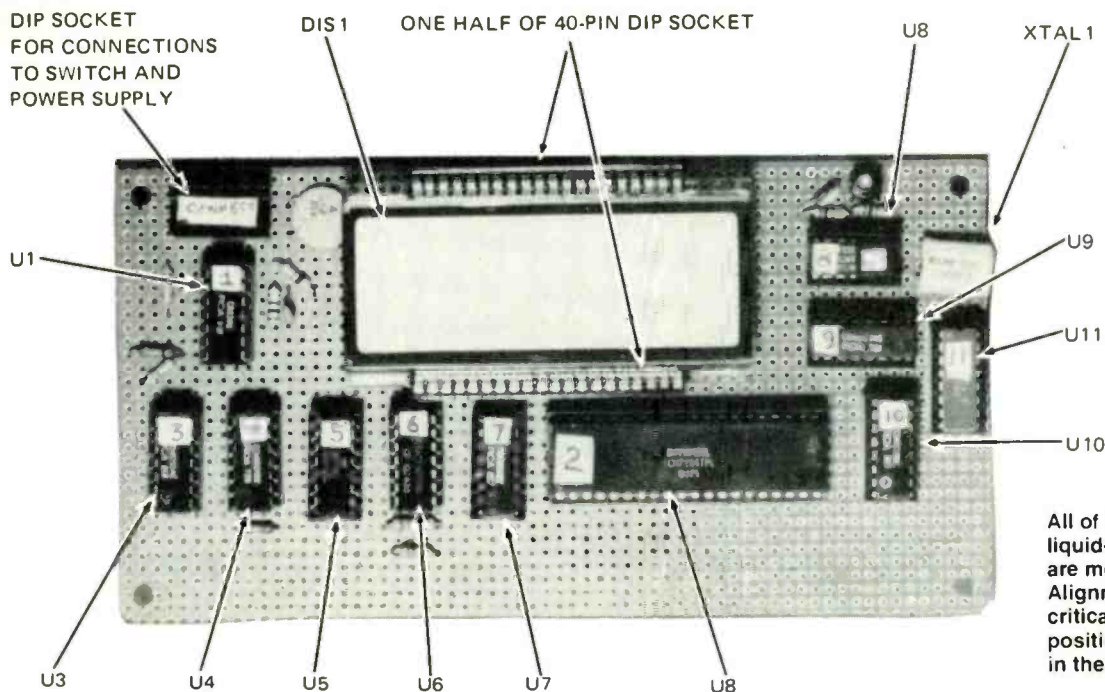

All of the IC's and the liquid-crystal display (DIS1) are mounted on a perfboard. Alignment of the display is critical since it must be positioned under a window cut in the chassis cover.

tor C3 is adjusted until that is the case.

Set the light sensitivity by varying R1 in the direction of increasing resistance until the arrow just comes on in the display and then, continue for another few degrees. (If you have an oscilloscope; you can look at the output of the comparator to see how much additional rotation gives a symmetrical output). If the brightness of the light source is constant and if the phototachometer isn't moved, there will be a broad range of sensitivity settings within which it will

indicate a count perfectly.

When using Phototach for other light sources, you merely have to ensure that the phototransistor receives a consistent change in brightness. With an aircraft propeller, for example, you can stand behind the propeller and see that the arrow goes off as the propeller is slowly rotated in front of Phototach before making the actual measurements. (Appropriate cautions should be observed when using Phototach behind an aircraft propeller. Obtain a firm stance with the pho-

### PARTS LIST FOR PHOTOTACHOMETER

- Q1—FPT-100 phototransistor (Radio-Shack 276-130)
- U1—LM339 quad voltage comparator integrated circuit
- U2—ICM7224 counter/divider integrated circuit (Intersil)
- U3—4013 dual D flip-flop integrated circuit
- U4—4001 quad 2-input NOR gate integrated circuit
- U5—4015 dual 4-stage serial-in/parallel-out shift register integrated circuit
- U6—4070 quad EXCLUSIVE-OR gate integrated circuit
- U7—4520 dual synchronous divide-by-16 counter integrated circuit
- U8—5369EST oscillator/divider, 100 Hz output integrated circuit (Jameco)
- U9—4027 dual J-K flip-flop integrated circuit
- U10—4518 dual synchronous divide-by-10 counter integrated circuit
- U11—4050 hex noninverting buffer integrated circuit
- U12—7805 (340T-5) 5-volt regulator

#### RESISTORS

(All fixed resistors are 1/4-watt, 5% units unless otherwise specified)

- R1—100,000-ohm, linear taper potentiometer (Radio-Shack 271-092 or equivalent)
- R2—100-ohm
- R3—10,000-ohm
- R4—36,000-ohm
- R5, R8, R11, R12—22,000-ohm
- R6—3000-ohm
- R7, R9, R10—10-Megohms

#### CAPACITORS

- C1—0.01- $\mu$ F, 50-WVDC, ceramic disk
- C2—39pF, 50-WVDC, ceramic disk
- C3—5–60-pF trimmer capacitor (Radio-Shack 272-1340 or equivalent)
- C4, C5—0.1- $\mu$ F, 50-WVDC, ceramic disk

#### ADDITIONAL PARTS AND MATERIALS

- B1—9-volt battery, transistor-radio type
- DIS1—4 1/2 digit, 3/4-inch, LCD readout (Crystalloid Electronics M5745 or equivalent)
- S1—SPST pushbutton switch, normally closed
- S2—DPDT slide switch
- S3—SPST slide switch (Power supply ON/OFF)
- XTAL1—3.579545-MHz crystal (Radio-Shack 272-1310 or equivalent)
- Perfboard, IC sockets, battery holder, battery clip, case, wire, hardware etc.

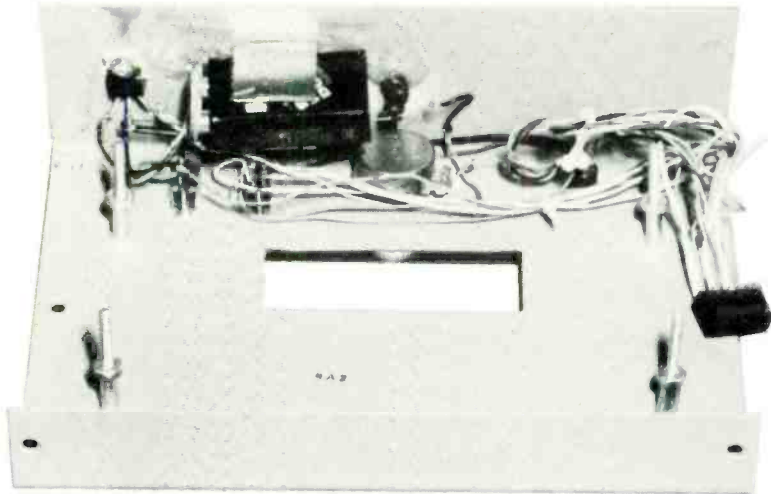

In the center of the chassis box (photo at right) is the cutout for the liquid-crystal display. The electrical rat's nest of wiring located at the top of the photo connects the controls, battery power supply, and phototransistor. Note the four screw posts with spacers in the photos and how the perfboard assembly in the photo (below) rests on them thus aligning the display with the cutout.

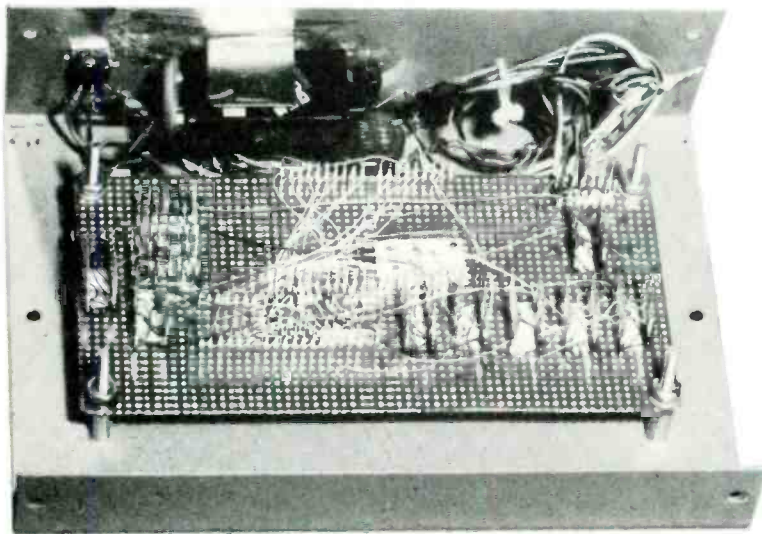

totachometer within 18-inches or so of the propeller after making sure that no debris ahead of the aircraft can be drawn into the propeller.) Be sure that the bright sky, and not a dark hangar, is in front of the propeller so that the propeller blade will make a significant change in the amount of light reaching the phototransistor. On a clear day the phototachometer has sufficient sensitivity to be used somewhat past official sunset. Use the HOLD button when you want to show the actual *rpm* to the pilot.

### Circuit Variations

Any periodic physical phenomena that can be converted into a fluctuating voltage relative to a 1- to 4-volt reference voltage (as adjusted by varying R4 and R5) can be used to trigger comparator U1 at its pin 11 input. That means pressure, temperature, and motion transducers, for example, can be used with this circuit.

The sampling period is easily adjusted by changing or adding to counters U9 and U10. For instance, the counter would record the number of fluctuations occurring over a whole hour at a time if the sampling period was changed to 3600 seconds by using two divide-by-six counters and two divide-by-ten counters after U8 to generate a  $\frac{1}{3600}$ -Hz gating signal.

Finally, if power considerations are not important or if night visibility is required, an Intersil 7225 counter IC can be substituted for the 7224; the 7225 provides the same functions but contains LED drivers rather than LC drivers. ■

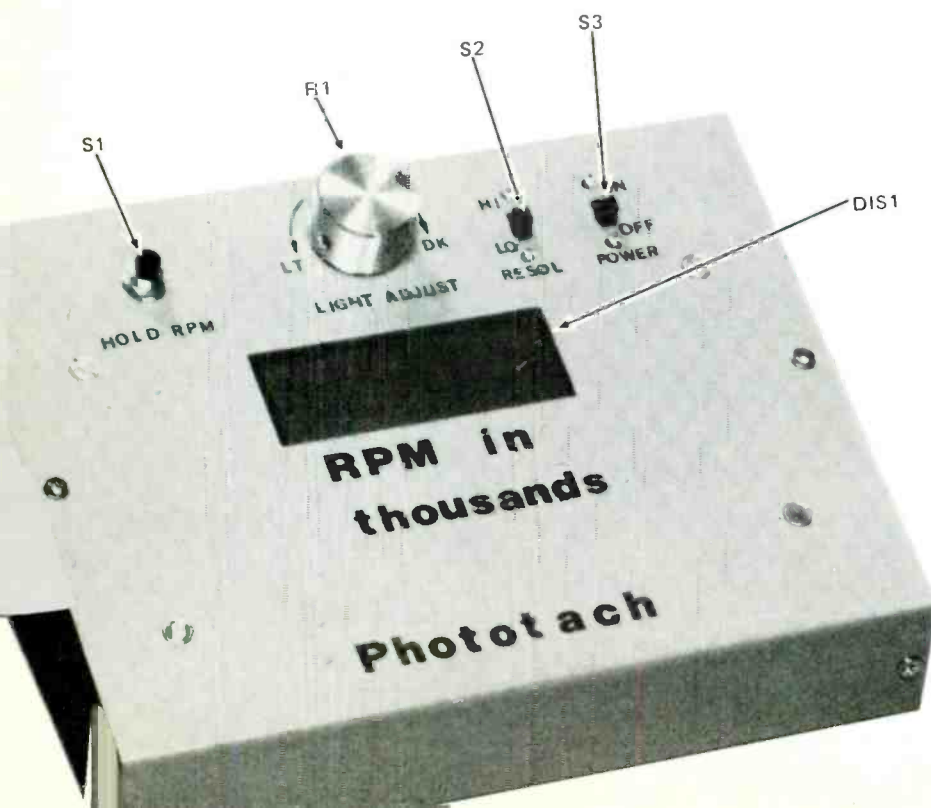

The completed Phototach is shown here. It has only four controls, one indicator display and a light-input port (not shown) on the rear apron of the aluminum chassis box.

# CALLING ALL HAMS

## String your own inverted long-wire antenna!

□ THE INVERTED LONG-WIRE IS AN EASY-to-erect long-wire antenna. At the usual antenna mounting heights, such a long-wire antenna displays some gain from its two ends at low-radiation angles that are favorable for DXing (Fig. 1). The inverted long-wire is center-fed. Antenna leg lengths are such that a low impedance is seen by the transmission line. That condition is met by making each antenna leg an odd multiple of a  $\frac{1}{4}$ -wavelength. An example was given in the previous column for a 15- to 40-meter antenna that had  $\frac{3}{4}$ -wavelength legs on 15 meters. The inverted long-wire antenna described here operates as a dipole on 80 meters,  $\frac{3}{2}$ -wavelengths on 20 meters,  $\frac{5}{2}$ -wavelength on 15 meters, and  $\frac{7}{2}$ -wavelength on 10 meters.

The basic cut (leg lengths) was made for operation as a  $\frac{3}{2}$ -wavelength antenna on 20 meters. Short add-ons were then used to tune the antenna for other bands. In our example, the antenna mast was 26-foot high and was constructed of three telescoping sections of PVC piping, as shown in Fig. 1. Inner diameters of the piping from top to bottom were 1 inch,  $1\frac{1}{2}$



Fig. 2—Antenna wire terminals and coax feed-through at top of PVC mast.

inch, and 2 inch. Construction on the PVC piping mast was detailed in previous columns. Three or four nylon or plastic rope guys can be used and attached to the two eye-ring through-bolts that join the two telescoping top sections of the mast.

The construction of the very top of the top-mast section is shown in Fig. 2. The two antenna wire terminals are the coax feed-through hole; that is used to provide a protected inner connection to the terminals for the inner conductor and braid of the coaxial line. A small cap fits over the top to provide weather protection.

Length of antenna wire was 50 feet, 1 inch to obtain resonance as a  $\frac{3}{2}$ -wave-

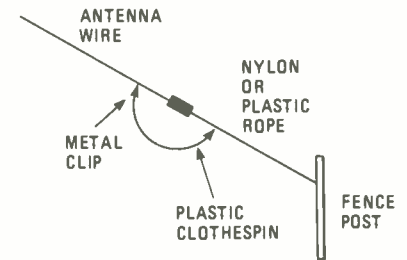

Fig. 3—Attachment of antenna add-ons.

length long-wire. Actual length is related to the height above ground of the apex and the apex angle set off as the antenna wires are stretched out to the ground-support posts.

Small, attached add-on lengths of wire can be used to resonate the basic long-wire antenna construction to 15 meters or 10 meters. The 10-meter add-on also resonates as a 75-meter dipole. The arrangement for attaching the add-on sections is shown in Fig. 3. A metal clip is used to attach the add-on to the very end of the 20-meter antenna wire. The other end of the add-on is attached to a plastic clothespin which in turn can be clipped on to the rope segment that stretches out to the antenna legs to the fence posts. The supported add-on to one antenna leg as well as the insulated clip are shown in Figs. 4 and 5.

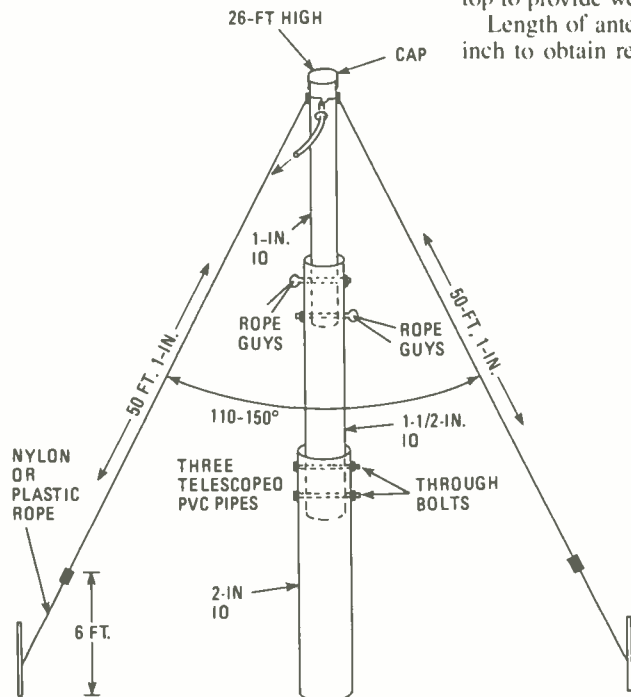

Fig. 1—Three-section PVC mast and inverted long-wire antenna for 20 meters.

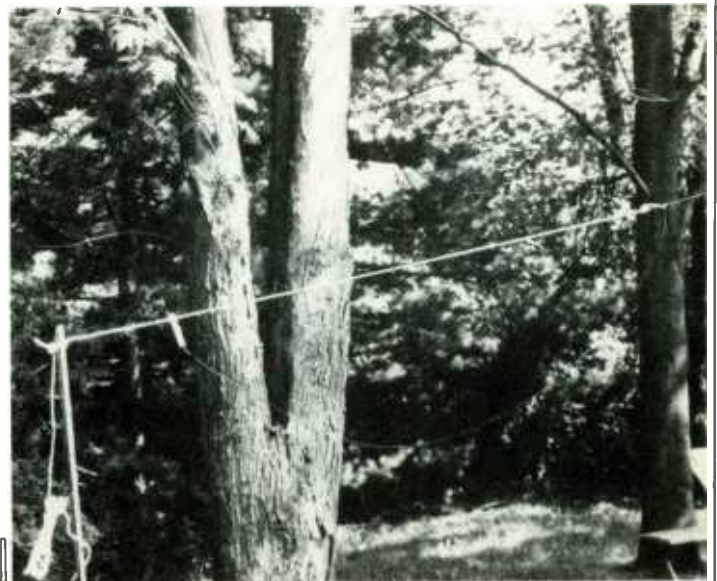

Fig. 4—10-meter add-on in place.

(Continued on page 99)



# GATE/POWER DRIVERS

Here are four packaged combos that will interface logic to action circuits!

□ A COMBINATION GATE AND DRIVER IN A SINGLE CHIP IS A handy item for applications such as driving incandescent lamps, relays, solenoids, and other interface devices. The Sprague Electric gate/power drivers discussed in this article have inputs compatible with DTL/TTL, PMOS, and CMOS devices. Power supplied to the devices can be as high as 80-volts DC, and the device has a 500-milliampere output heat-sink-current capability per gate. The M suffix after each gate/power driver indicates a low-cost plastic case, ideal for experimenter's applications, and each device can be operated in the  $-20^{\circ}\text{C}$  to  $+85^{\circ}\text{C}$  range. The devices have no suppression diodes for transient protection, so those must be included in the circuit when the load to be switched is inductive. Sprague Electric makes available four gate/power driver chips that will be discussed in this article. They are:

- UDN-3611M Dual AND Driver
- UDN-3612M Dual NAND Driver
- UDN-3613M Dual OR Driver
- UDN-3614M Dual NOR Driver

## The Dual AND Driver

Pin-out and basic circuit of the dual AND driver version are given in Fig. 1. Each of the dual sections consists of a NAND gate and a follow-up bipolar transistor output. Check out the logic of the AND driver with the appropriate logic chart in Table 1 and Fig. 1. There is no direct pin-out for the output of the NAND gate. The Y output of the NAND gate (Fig. 1) is connected internally to the base of the bipolar transistor. The following bipolar transistor results in a logic inversion. Therefore, the output has a logic corresponding to that which would be obtained from an overall AND gate. Treating the UDN-3611M chip as a black box with one output, it appears to be an AND logic device. The AND operation is the result of

the inversion of the logic that appears in the Y output of the NAND gate.

Pin-outs are identical for the AND, NAND, OR and NOR drivers. However, internal gate for the NAND driver has AND logic; internal gate for the OR driver, NOR logic; and, internal gate for the NOR driver, OR logic. Those relations are shown in the remaining truth listings in Tables 2, Table 3, and Table 4.

Gate/power drivers of that type are useful in driving peripheral loads such as incandescent lamps, displays, heaters,

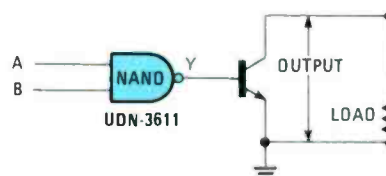
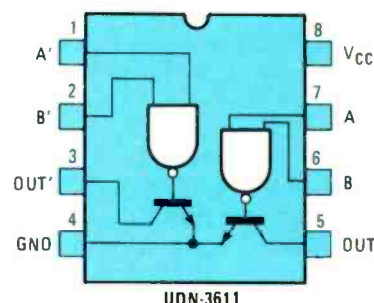

Fig. 1—The UDN-3611M dual gate/power driver is shown schematically (A) within the physical outline of its DIP configuration. A simplified diagram (B) of one driver section is shown. Point Y is not electrically connected to one of the output pins. It is identified for circuit discussion in text.

TABLE 1  
AND Gate/power Driver  
Truth Table

A	B	Y	OUT
0	0	1	0
0	1	1	0
1	0	1	0
1	1	0	1

TABLE 2  
NAND Gate/power Driver  
Truth Table

A	B	Y	OUT
0	0	0	1
0	1	0	1
1	0	0	1
1	1	1	0

TABLE 3  
OR Gate/power Driver  
Truth Table

A	B	Y	OUT
0	0	1	0
0	1	0	1
1	0	0	1
1	1	0	1

TABLE 4  
NOR Gate/power Driver  
Truth Table

A	B	Y	OUT
0	0	0	1
0	1	1	0
1	0	1	0
1	1	1	0

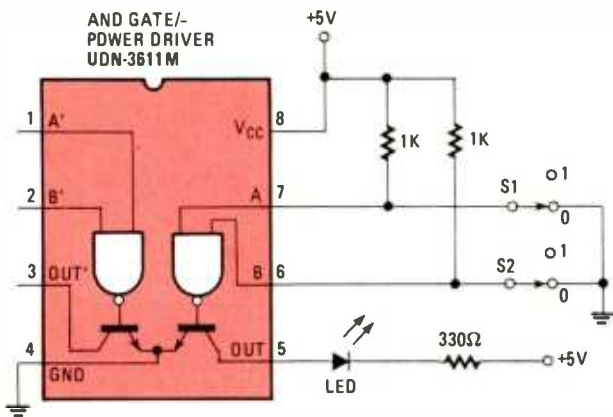

Fig. 2—Basic gate and output hookup for the UDN-3611M dual gate/power driver chip. The output transistor can work on DC up to 80 volts and .5 ampere. Connecting the dual section in parallel doubles the current capacity to 1 ampere.

relays, memories, solenoids, and stepping motors. Some form of diode transient suppression is recommended for inductive loads. A single section in the dual chip is capable of sinking 300 mA. By connecting the two sections in parallel, a 600-ampere sink is possible.

### Check-out Circuit

A very simple check-out circuit for the AND gate/driver shown in Fig. 2 can be built on a solderless circuit board. The UDN-3611M AND chip is used. AND logic is applied to pins 6 and 7. Output is derived at pin 5. A LED and 330-ohm current-limiting resistor are used to provide a power sink and visual indication. The output LED comes on when any gate input is at logic 0. If both inputs are at logic 1, there will be no sink current and the LED will go off.

Since the internal gate for the AND driver has an internal NAND logic element, don't let it throw you! The actual output of the AND driver is such that the LED will light for three of the four possible input logics and will be off when both A and B inputs are at logic 1. Wire the circuit and checkout operation using logic switches S1 and S2. A switch closed will result is the application of logic 0; switch open, logic 1.

### Complete Driver Demonstrator

A complete AND driver demonstrator is given in Fig. 3. The simple switching arrangement of Fig. 2 is used for logic inputs to one dual section, while the output of a slow clock output from a 555 chip is applied to other input for the second dual section. Clock gating is handled by switch S3. If you wish, wire the AND driver demonstrator circuit shown in Fig. 3 on a solderless circuit board.

Place the circuit (Fig. 3) in operation by applying power—+5-volts DC. The CLOCK LED will come on each time the clock output at pin 1 of the driver is at logic 0 and switch S3 is set at logic 1. The CLOCK LED comes on and off at the clock rate. When S3 is at logic 0, the CLOCK LED will not come on.

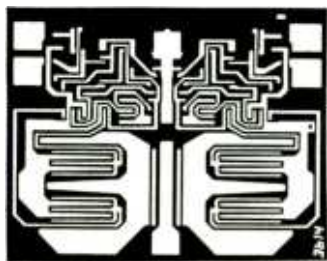

Metal mask for the UDN-3614M chip. Note large-geometry power transistors. Logic sections are smaller.

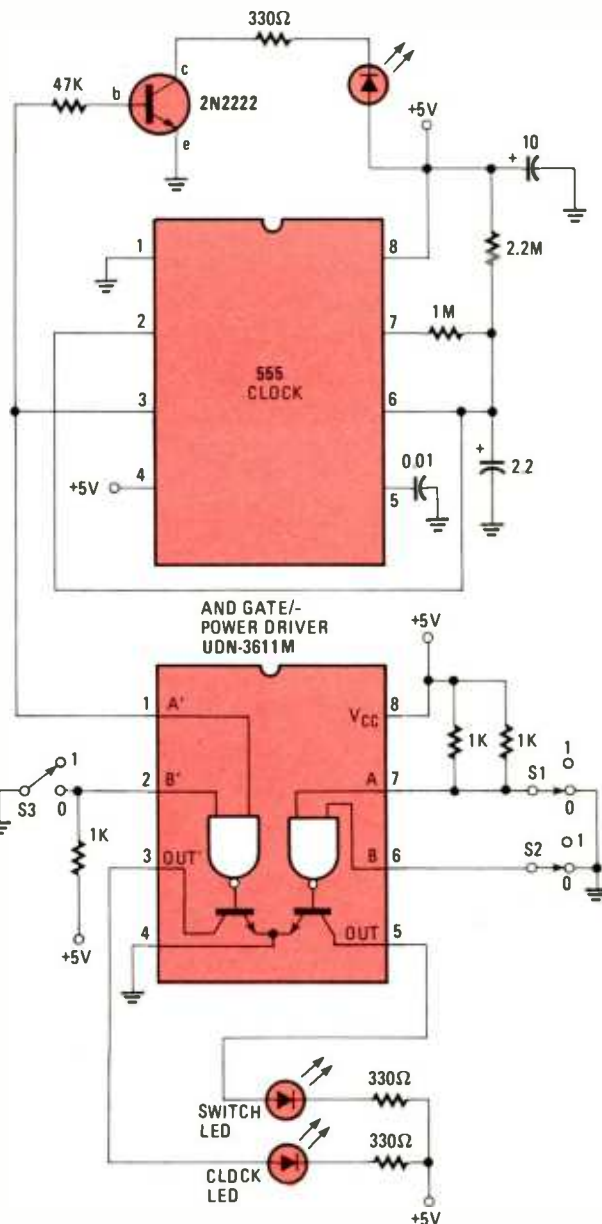

Fig. 3—Driver demonstrator circuit uses a 555 timer to provide a slow clock input to the UDN-3611M dual AND gate/power driver. Clock input to pin 1 of the driver is constantly switching from 0 to 1. Switches S1, S2, and S3 provide other logic inputs used to verify operation as described in text.

Note that the SWITCH LED will come on when either or both logic switches are at 0. Check that operation using switches S1 and S2 and comparing results with Table 1.

### The Dual NAND Driver

You will probably find the dual NAND driver useful because of its special attributes for turn-on activities. Remove the AND gate chip (UDN-3611M) you set up on the solderless circuit board and replace it with a NAND type (UDN-3612M). For the following discussion refer to Table 2. Place the circuit in operation. Open switches S1, S2 and S3. By so doing you apply a logic 1 to the gates. Both LED's will light—the CLOCK LED will clock on and off and the SWITCH LED remains on continuously. Set switch S3 to a logic 0. That action will inhibit the clock from switching the driver output although gate input from the clock will continue to switch from logic 1 to logic 0, and back again.

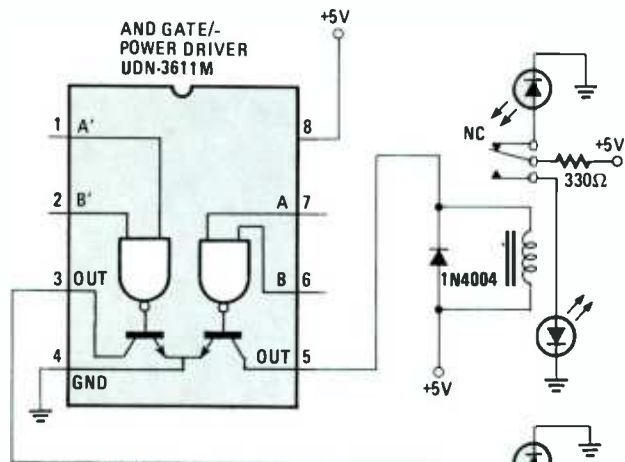

Fig. 4—The test setup in Fig. 3 can be modified to operate a small relay as detailed here. LED's serve as the load in this circuit, however they can be replaced with inductive loads of higher current without damaging the gate/ power driver. One of four different dual gate/ power drivers can be used in this circuit and the circuit of Fig. 3.

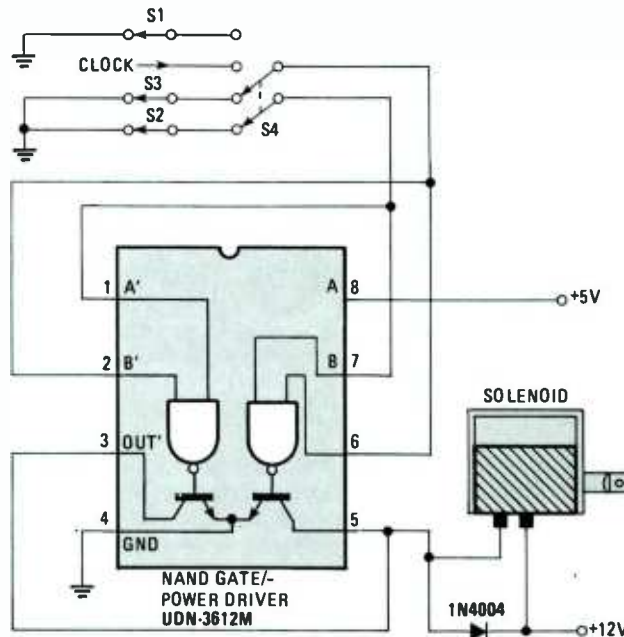

Fig. 5—Another circuit variation that can be performed on the basic circuit presented in Fig. 3. Here, the dual sections are connected in parallel and the choice of logic control is provided by switch S4. The driver transistors can be connected to a power supply up to +80-volts DC.

Close switch S1 or switch S2 or both to a logic 0 and the SWITCH LED will turn off.

### OR and NOR Drivers

Remove the NAND gate and replace with an OR gate. Open switches S1, S2 and S3. Apply power. Both output LED's remain off. Clock is being generated but is inhibited.

Close switch S3. A logic 0 applied to pin 2 will open the gate and associated LED will turn on and off at the clock rate.

Close switches S1 and S2. This is the only logic combination that will turn on the associated output LED.

Again in many applications the NOR driver may be more useful than the OR driver. Make an appropriate substitution. For this driver, output will be activated (sink current present) when either or both inputs are at logic 1. Clock output requires that switch S3 be closed to apply a logic 0 to pin 2.

In the demonstration circuits that follow, two relays and a solenoid will be driven directly by the outputs of the gate/ power driver. The driving of power circuits can be more readily understood by using a NAND gate/power driver in the

basic circuit of Fig. 4.

No other change need be made with the exception that the two relays are connected to the outputs at pin 3 and pin 5 as shown in Fig. 4. The relays selected are Radio Shack 275-246 types. Their coil voltage is 5-volts DC and output contacts are capable of handling 3 amperes at 125-volts AC.

In the demonstration circuit LED's are used instead of AC devices. You will understand that 3-ampere devices can be operated by the relay contacts. Relay current required is 72 mA which can be supplied easily from a single-gate driver.

Add the relays to your circuit. Check out the operation. When switch S3 is at logic 1 (see Fig. 3) the associated output LED will turn on and off at the clock rate. When the clock input to the gate/power driver is a logic 1, the relay is de-energized. You can check that out using switches S1 and S2. Both must be set to apply logic 1 if the associated relay is to be de-energized.

Solenoid operation can be demonstrated using a Radio Shack 273-251 type that uses a 12-volts AC solenoid. In this demonstration a 12-volt source is required. Recall that the

*(Concluded on page 101)*

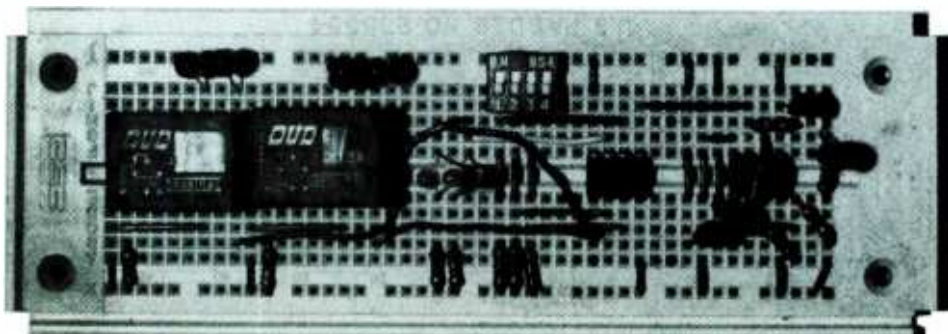

The author setup the circuit in Fig. 5 on a solderless circuit-board. The two large dark squares are PC-mount relays. The smaller black squares are the 555 (clock) and UDN-3612M chips.

# ON DX'ING



# JENSEN

## Reaching out to log the nations of Asia

□ FOR SHORTWAVE LISTENERS, ONE OF the most interesting continents in which to hunt for DX signals is Asia.

In the imagination, certainly, and often in reality, Asia is exotic and exciting. For the SWL interested in DX as a window to the world of current events, Asia is a prime news focus, although the emphasis in recent years has shifted from the Far to the Middle East.

There is no one Asia. Asia is diversity. It runs from the Arctic to the palm-fringed shore of the Indian Ocean; from the Gobi to the Himalaya peaks, and from its border with Europe, thousands of miles eastward to the Pacific.

Asia has one-third of the earth's land mass. Its people are yellow and brown and white, and they speak countless languages and dialects.

Nowhere is that multiplicity of language more apparent than on the shortwave bands.

We continue the continent-by-con-

continent overview of what you can hear on shortwave—both easy catches and some difficult loggings—with a look at Asia.

**CHINA.** Asia's largest country, has come a long way in its external broadcasting. Some years back, *R. Peking*—as it was then known—was rather dismal! Not only were the programs loaded with anti-American, anti-West propaganda, they suffered from the fatal flaw of being dead-ly dull!

Things have improved somewhat. Today's *R. Beijing* even has a program for SWL's.

Here are some times and frequencies to try for English programming from *R. Beijing*:

0000 GMT/UTC—10,865, 11,650, 15,385 kHz

0200 GMT/UTC—10,865, 11,650, 17,795 kHz

1100 GMT/UTC—15,520 kHz

1200 GMT/UMT—11,650, 15,520 kHz

**TAIWAN**—The *Voice of Free China* operates from Taipei, Taiwan. Try around 0100 GMT/UTC on 11,825 or 15,345 kHz.

If you find that station in Chinese or English during the North American evening hours, with powerful signals on 5,985 or 11,740 kHz, the transmission is not being broadcast directly from Taiwan. It being relayed by WYFR, a U.S. shortwave station in Florida.

WYFR relays the *Voice of Free China* during certain hours in exchange for the rebroadcasting of its own religious programs from Taiwan transmitters.

**JAPAN**—In DX'er interest, another popular target is Tokyo's *R. Japan*, a station which for years has gone out of its way to accommodate shortwave listening fans, particularly with its many gorgeous, full-colored QSL or verification cards, sent out in response to correct reception reports.

You can try for *R. Japan* on a number of frequencies, 9,675, 11,755 kHz at 0100 GMT/UTC; 9,675, 15,300, 17,810 at 0500 GMT/UTC.

Or: At 1100 GMT/UTC on 9,505, 9,580, 15,195 kHz; at 1300 GMT/UTC on 9,505, 11,815, 11,840 kHz.

A lesser known and less frequently heard Japanese SW'er is the Nippon Shortwave Broadcasting Co. *R. Tanpa*, headquartered at Tokyo. West Coast listeners in particular can look for that one around 0830 GMT/UTC on 6,055 kHz.

**INDIA**—Another of the major Asian countries is India. Here all broadcasting is controlled by the government's *All India Radio*. Its English-language foreign service is known as the *General Overseas Service* and it has been heard often in North America during the 2045 to 2230 GMT/UTC time slot on 9,595, 9,912 or 11,755 kHz.

**PAKISTAN**—Sharing the great Asian subcontinent with India is Pakistan. One of the best times to hear Pakistan in English is at 0230 GMT/UTC, with slow-speed news on 17,839 kHz.

Or you can find *R. Pakistan* in the Hindi  
(Continued on page 99)



This well equipped DX'ing set-up belongs to Swedish DX'er Ole Alm. While Ole DX's for stations throughout the world, he specializes in home service transmissions from the Soviet Union.



# ON SCANNERS

## SAXON

**All about repeaters that extend the range of VHF and UHF mobile units!**

□ MANY VHF AND UHF COMMUNICATIONS systems rely upon the use of repeaters. Such devices offer a number of benefits to those using two-way communications. The primary benefit that they allow is a substantial increase in transmissions range for the portable and mobile stations within a communications system.

Understanding some of the basics of repeaters, as they are used in land mobile radio, offers scanner users insight and opens the door to getting more from their monitoring enjoyment.

### What It Is

A repeater is, essentially, a two-channel device. One channel is used to transmit to portable/mobile units. The other channel is used to receive signals from the portable/mobile units. That is sometimes called the *talk-back* or *talk-in* channel. The most commonly encountered terms used to refer to those channels are the *repeater-downlink* frequency for the repeater's transmit channel, and the *repeater-uplink* frequency for the receive channel. Systems in the 450- to 470-MHz band normally have the uplink frequency exactly 5-MHz higher than the downlink frequency. For instance, a repeater that transmits on 460.25 MHz would receive on 465.25 MHz. For systems in the 470- to 512-MHz band, the separation is only 3 MHz. Thus, you would expect that a repeater on 482.0125 MHz would receive on 485.0125 MHz. Repeaters operating in the 152- to 174-MHz band do not have a uniform separation of uplink and downlink frequencies, although the uplink frequency is usually higher in frequency than the downlink frequency.

Scanner owners would normally wish to monitor only the repeater downlink frequency since it carries (or repeats) all of the transmissions taking place on the uplink frequency. The repeater is usually located atop a mountain or tall building in order for the site to give it maximum transmitting and receiving range. The repeater will then be able to pickup from distant low-powered *hand-helds* and mobile transmitters. You, at home, would never hope to hear those direct transmis-



**This USAF C-130-type aircraft crash-landed at Amarillo Airport. Such accidents have special frequencies to be activated for use by fire and crash personnel.**

sions (that is, if you were listening on the repeater's uplink access frequency).

Some of the things that have confused scanner owners about repeater usage are actually rather straightforward once the mystery is removed. One constantly asked question relates to mobile or portable units sometimes announcing that they are switching to an alternate frequency (sometimes called "F-2"), only to seemingly vanish from the airwaves.

That is a clever trick which permits mobile units to have short-range direct communications without tying up the repeater. It also offers some degree of communications privacy. What the mobile units have done is to switch over to transmit and also receive on the downlink frequency. Their signals will no longer pass through the repeater and be heard over a wide area, although they will still be able to monitor the repeater for any messages that might be directed to them. Scanner owners monitoring the repeater's downlink frequency would hear such transmissions only if they were being made within a relatively short distance from the scanner's antenna.

### From Hq to Repeater

Scanner users also ask about how the signals from the office or headquarters are fed to a remotely located repeater atop a mountain, and how the mobile units' signals are sent from the location to the distant office or headquarters dispatching point. In some cases that is done by telephone ("landline"). That may also be accomplished by special radio links. Those links could be on other VHF or UHF channels, or maybe by microwave devices. Another way of accomplishing that is by simply establishing the base station(s) in a system on the same uplink-transmit/downlink-receive frequencies as any of the portables and mobiles in the system.

The chances are that most of the dispatching you're hearing above 450 MHz is by means of repeaters. Virtually all of the transmissions you're hearing from mobile units operating on UHF are merely being retransmitted through a repeater rather than being heard direct. Also, any mobile or ship-to-shore telephone calls you've monitored are going through re-

*(Continued on page 103)*

# LOW-POWER POLARITY INVERTER

By Warren Baker

□ FROM TIME-TO-TIME IT IS NECESSARY TO INVERT THE POLARITY of a supply voltage that is already available. Although there are several accepted ways in which to accomplish the feat, the one covered by this article is simple, inexpensive, and fun to build. In addition, the project itself may also appeal to those hobbyists who are attempting to learn more about the fascinating subject of electronics. In the latter case, not only will the beginner obtain some useful experience building simple circuitry, but he will also get a first-hand opportunity to use the astonishing and multi-purpose 555 timer integrated circuit.

## How It Works

As mentioned already, the heart of the Low-power Polarity Inverter circuit is one 555 timer integrated circuit, easily purchased for under a dollar nearly everywhere. With the addition of a few inexpensive small parts, a low-power polarity inverter can be assembled.

The circuit shown in Fig. 1 will operate on a wide range of DC voltage inputs. In fact, a useable output can be obtained with as little as 3 volts applied to terminals 4 and 8 of the 555. With little or no load, there will be about one-volt loss in the inverting process. That actual amount of loss will vary with the actual input voltage and, of course, the load current.

The circuit operates as follows: The 555 sets up an oscillation that causes pin 3 to be alternately *high* and *low*. When pin 3 goes high, say to +5-volts, diode D1 is forward-biased, diode D2 is reverse-biased, and capacitor C3 charges up to 5 volts.

But when pin 3 goes low, capacitor C3 discharges through D1 and charges up capacitor C4. Diode D2 prevents C4 from discharging so that what you wind up with is a negative voltage at the anode of diode D2.

Since the external load is taken from across the output capacitor (C4), it follows that the actual current that may be available is limited by the amount of charge that can be stored by C4. Thus, it also is obvious that the larger the capacitance

of C4, the more current that will be available for the external load. There are, however, some practical limits to that. In addition, the quality of the capacitor will have a direct bearing upon the exact amount of voltage and current available.

## Building the Circuit

Any reasonable construction technique may be used to build the circuit. As you can see in Fig. 2, the author's prototype was built on a solderless breadboard. If you wish to experiment with the circuit, that technique gives you the maximum flexibility. For other applications, a more permanent technique (printed-circuit board, point-to-point wiring, etc.) should be used. For instance, once the author's final version was arrived at, the circuit was transferred to a Global Specialties' *EXP-300-PC* pre-etched printed circuit board. That board directly matches the layout of the Global solderless breadboard used in designing the circuit. Soldering the components in place was all that was then required to complete construction.

Just about any part in this project can be substituted to match whatever values are available in your junkbox. The frequency of oscillation is determined by the values of R1 and C1. That frequency is not critical and therefore you may substitute for those components as you see fit. The values of

*(Continued on page 97)*

## PARTS LIST FOR LOW-POWER POLARITY INVERTER

### SEMICONDUCTORS

D1, D2—1N914 diode, or available similar types  
U1—555 timer integrated circuit

### ADDITIONAL PARTS AND MATERIALS

C1—0.1- $\mu$ F, ceramic-disc capacitor  
C2—50- $\mu$ F, 25-WVDC, electrolytic capacitor  
C3—33- $\mu$ F, 10-WVDC, electrolytic capacitor  
C4—20- $\mu$ F, 25-WVDC, electrolytic capacitor  
R1—470-ohm, 1/4-watt, 5%, resistor  
Solderless breadboard, wire, etc.

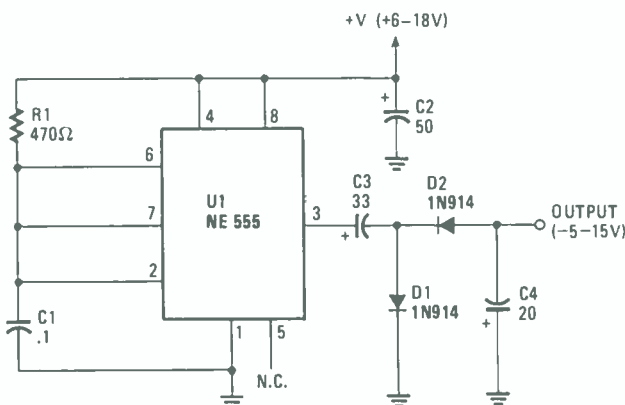

Fig. 1—Although the use of only one resistor in a 555 timer circuit may seem unusual, the circuit shown here worked well for the application described in the article.

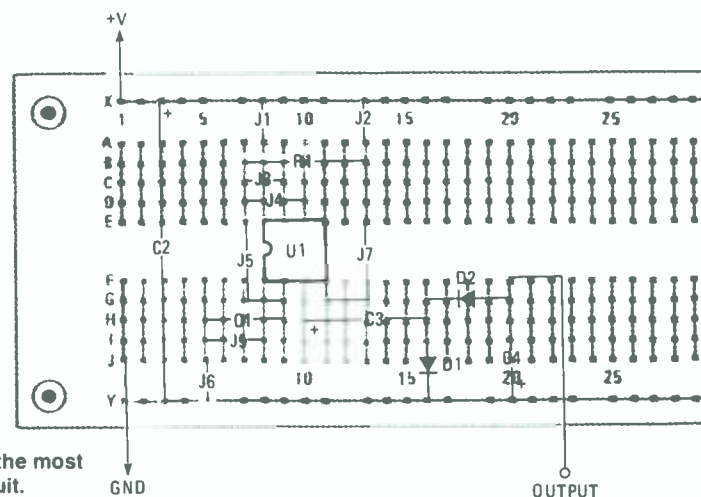

Fig. 2—Use of a solderless breadboard allows you the most flexibility when experimenting with this supply circuit.

# Push-On/Push-Off Electronic Switch

By Robert F. Scott

MECHANICAL PUSH-TO-MAKE, PUSH-TO-BREAK SEQUENTIAL switches are available, but when you need one, you'll probably have trouble getting it in the style or electrical ratings you need. An electronic equivalent can be made by using an Eccles-Jordan flip-flop circuit to drive a relay that has switching contacts to handle the load you want to control. We call our circuit the Push-on/Push-Off Electronic Switch, and we believe that it will be cheaper to build than buy. Why? Because you will be able to select an available and inexpensive relay, or possibly have one in your junkbox right now.

The circuit for the Push-on/Push-off Electronic Switch is shown in Fig. 1. Transistors Q1 and Q2 make up the flip-flop while Q3 drives a reed relay. When power is first applied to the circuit, Q1 and Q3 are conducting and Q2 is cut off. Momentarily closing S1 causes the flip-flop to switch

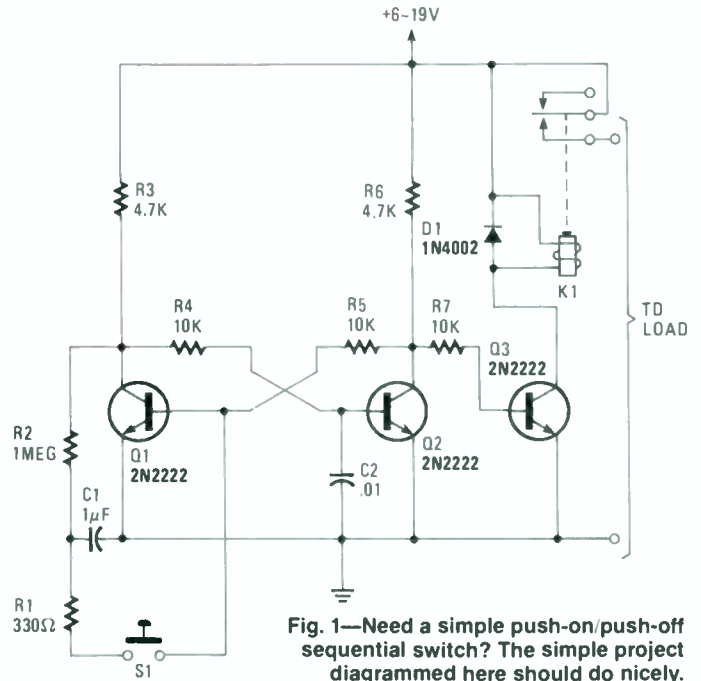

Fig. 1—Need a simple push-on/push-off sequential switch? The simple project diagrammed here should do nicely.

## PARTS LIST FOR PUSH-ON/PUSH-OFF ELECTRONIC SWITCH

### SEMICONDUCTORS

Q1, Q2, Q3—2N2222 PNP silicon transistor, or equal  
D1—1N4001 silicon diode or equal

### RESISTORS

(All fixed resistors are 1/4-watt, 5% units)  
R1—270-ohm  
R2—1-Megohm  
R3, R6—4700-ohm  
R4, R5, R7—10,000-ohm

### CAPACITORS

C1—1-μF, mylar or metal film  
C2—.01-μF, ceramic disc

### ADDITIONAL PARTS AND MATERIALS

K1—Reed relay, 5-VDC, 180- to 220-ohm coil; 1-A at 125-VAC contacts (Radio Shack 275-232)  
S1—SPST, normally open  
Breadboard--solderless type, enclosure, wire, etc.

states—Q1 cuts off and Q2 conducts. When Q2 is conducting, its collector drops to around 0.6 volt. That prevents base current from flowing into Q3 so it is cut off, de-energizing relay K1. The flip-flop changes state every time S1 is pressed.

Capacitors C1 and C2 ensure that Q1 is always the transistor that turns on when power is first applied to the circuit. When power is first applied to the basic flip-flop, the initial state is random—Q1 and Q2 both try to conduct; and, usually, the transistor with the higher gain will take control, reaching full conduction and cutting off the other one. However, differences in the values of the collector and coupling resistors will also influence the initial state at power-on. With C2 in the circuit, it and R4 form an R-C network that slightly delays the rise in Q2's base voltage. That gives Q1 sufficient time to reach saturation and thus take control.

The reed relay, K1, used in this project is a Radio Shack type (see Parts List) with contacts rated at one ampere at 125-  
(Continued on page 95)

Fig. 2—The author's prototype was built on a solderless breadboard. The layout used is shown here.

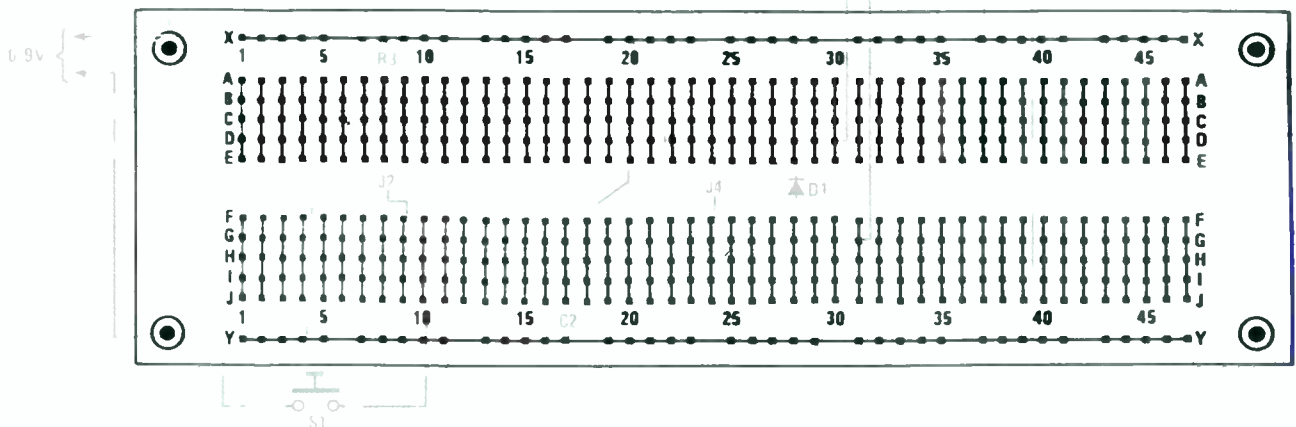

## NEW PRODUCTS

(Continued from page 14)

sitivity and triggering capabilities that conventional oscilloscopes are already noted for.

Like all other Leader products, the LBO-5825 35-MHz, 2-channel digital storage oscilloscope is covered by a two-year warranty for all parts and labor including the CRT. It is priced at \$3,850. For more information contact Leader Instruments Corporation, 380 Oser Avenue, Hauppauge, NY 11788. Tel.: 516/231-6900 or 800/645-5104.

## Apple-II Prototyping Board

A prototyping board for Apple-II microcomputer, from Vector Electronic Company, supports interface development with space for a variety of input/output connectors. A companion extender card provides test points for each check-out and troubleshooting.

The prototyping board, Model 4609-1, is fully form- and plug-compatible with Apple-II cards and has a dedicated I/O area with drilled holes and pads to mount either a D-subminiature or a flat-cable connector. The board accommodates DB25 to DB37 connectors for RS-232 I/

O, or up to 40-pin flat-cable connectors.

The 13.2-square-in. device-mounting areas has .042-in. diameter holes drilled on 0.1-in. centers so that IC's and components may be located conveniently for wrapped wiring. Heavy-duty +5-V and ground busses surround the device mounting area.

The Model 3690-24 extender card includes a 50-pin card edge for Apple II bus, connector, and adjacent test points, which may be mounted on either side of the card. The points are configured as

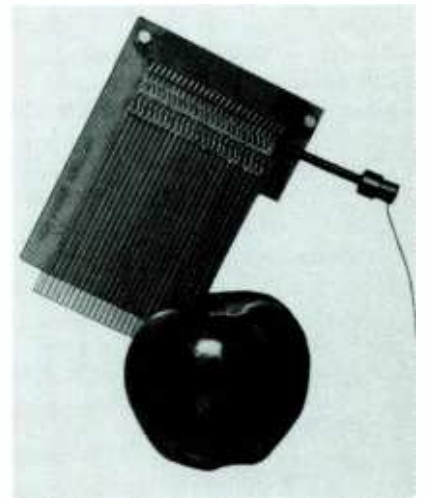

CIRCLE 942 ON FREE INFORMATION CARD

loops to allow connecting multiple probes or test leads to the circuit board traces. Solder masking on the bus lines protect against inadvertent short circuits.

The Model 4609-1 is fabricated of blue epoxy-glass composite. The board measures 2.75-in. high by 7.70-in. long. The Model 3690-24 is fabricated of 0.062-in thick, FR4 green epoxy-glass material. The card extender measures 2.86-in. high by 3.12-in. long.

In single quantities, the Model 4609-1 is priced at \$20.66 each and the Model 3690-24 is priced at \$32.63 each. For information write to Vector Electronic Company, 12460 Gladstone Avenue, Sylmar, CA 91342. Tel.: 818/365-9661.

## Three Compact Speakers

Revox has introduced a line of compact, low-priced speakers: The Piccolo, the Studio 3, and the Studio 4. They are built by Revox to the same renowned high quality and performance standards of its other speakers and audio equipment. Revox expects the new speakers to be particularly popular for such new audio applications as stereo television.

The smallest speaker, the Piccolo, is a two-way design only 5½-in. wide by 8¼-in. high by 5¾-in. deep. It is finished in flat black, with a perforated metal grille. The suggested list price is \$99 each.

The larger Studio 3 and 4 speakers share similar construction and finish. The

## COMPUTER PAPERBACK BOOKS

### Great Books For The Computer Hobbyist

CHECK OFF THE BOOKS YOU WANT

**PROGRAMMING THE ZX SPECTRUM**...\$7.50. Make this color computer do its stuff. With this book in hand it's easy.

**AN INTRODUCTION TO PROGRAMMING THE ATARI 800/800XL**...\$5.00. This book is designed to complement the information supplied by the manual for all Atari owners.

**DIGITAL IC PROJECTS**...\$3.00. Simple & more advanced projects intended to help develop a knowledge of digital circuits.

**A PRACTICAL INTRODUCTION TO MICRO-PROCESSORS**...\$6.00. The reader will construct his own simple microprocessor or circuit and learn more about how microprocessors work.

**AN INTRODUCTION TO BASIC PROGRAMMING TECHNIQUES**...\$5.00. Based on the author's own experience in learning Basic & helping others to learn to program & understand the language.

**20 PROGRAMS FOR THE ZX SPECTRUM & 16K ZX81**...\$5.00. Included with each program is a detail flow chart for both games and practical applications including statistics and engineering.

**A MICRO-PROCESSOR PRIMER**...\$4.50. We start by designing a small computer and look at how the microprocessor plays its role in making the unit work effectively.

**THE 6809 COMPANION**...\$5.00. Discusses the features of the 6809 and a reference work for 6809 programmers.

**MICRO INTERFACING CIRCUITS**—Book 1...\$5.75. In-depth coverage of how the expansion can interface add-on cards to the home computer to transform it into a sophisticated piece of control equipment.

**ART OF PROGRAMMING THE 16K ZX81**...\$8.25. What happens when you add the RAM POKER, Scrolling PEEK, POKE, Page graphics and more.

**ELEMENTS OF ELECTRONICS VOL. 4—MICROPROCESSING SYSTEMS & CIRCUITS**...\$7.50. Comprehensive guide to the elements of micro-processing systems. An economical & interesting initiation into the world of microprocessors.

**A 2-80 WORKSHOP MANUAL**...\$6.95. Describes typical machine code instructions followed by a detailed description of the 2 80 by language programming is also covered.

**EASY ADD-ON PROJECTS FOR SPECTRUM, ZX81, & TRIM**...\$6.50. Pulse detector, picture digitizer, 5-key pad, model controller, light pen and more.

**PRACTICAL COMPUTER EXPERIMENTS**...\$4.50. Fills in the background to the microprocessor by constructing typical computer circuits in discrete logic.

**SECRETS OF THE COMMODORE 64**...\$5.00. Presents masses of useful info and programming tips.

**BASIC & PASCAL IN PARALLEL**...\$4.25. Develops programs in both languages simultaneously. Sample programs illustrate structure.

**AN INTRODUCTION TO PROGRAMMING THE ORIC-1**...\$5.00. A new authoritative manual for owners of this new personal computer.

**ELECTRONIC TECHNOLOGY TODAY INC.** HOE # 3  
P.O. Box 240, Massapequa Park, NY 11762-0240

Number of books ordered

Total Price of Books \_\_\_\_\_

Sales Tax (NY State Residents only) \_\_\_\_\_

Shipping and Handling (75¢ for 1 or 2 books 30¢ each add'l book) \_\_\_\_\_

TOTAL ENCLOSED \_\_\_\_\_

Name \_\_\_\_\_

Address \_\_\_\_\_

City \_\_\_\_\_ State \_\_\_\_\_ Zip \_\_\_\_\_

PRICES GOOD UNTIL APRIL-30, 1985





**CIRCLE 962 ON FREE INFORMATION CARD**

Studio 3, a two-way design, carries a suggested list of \$175 each; the 3-way Studio 4, a suggested list of \$249 each.

Enclosures for the compact speakers have the same massive low-resonance design used in larger Revox speakers. Driver voice coils are manufactured in Revox's

own factories, to assure the precise, tight wind that is essential for magnetic field strength and high efficiency. Tweeter diaphragms use reinforced, sandwich-type construction and have an acoustic lens in front.

For additional information, write to: Revox Division, Studer Revox American, Inc., 1425 Elem Hill Pike, Nashville, TN 37210.

### Direct-Line Receiver

Scientific Audio Electronics (SAE) has introduced the R-102, a 50 watt-per-channel receiver. A Rockwell computer chip programmed by SAE engineers allows the circuitry to be isolated from the front panel. Since front-panel controls no longer come in direct contact with internal circuitry and the audio signal, there is no need for audio switches. All audio circuitry is located at the rear of the unit, allow-

ing the signal path to be reduced dramatically (more than 50 percent). That audio-path reduction reduces the possibility of hum, crosstalk, and other audio



**CIRCLE 941 ON FREE INFORMATION CARD**

interference found in conventional receivers.

The SAE phono power AMP—a separate power amplifier for the phono circuit—provides extra power necessary to drive both the phono-equalization network and associated stages accurately. A main power amplifier capable of delivering high current is needed to handle low impedance loads. The R102 is all touch-

*(Continued on page 104)*

## BRITISH HEE-HAW SIREN

*(Continued from page 72)*

output load impedance for that device. Lower impedances may draw excessive load currents (higher than 200 mA) and thus increase internal power dissipation to beyond the device's rating. When lower-impedance speakers are used, select R6 so pin 3 sees a total of 75 ohms.

When you must use a series resistor, the power divides in proportion to the impedance values. Thus, when R6 is greater than the speaker impedance, it will dissipate most of the available power and the volume will be low. When using a 9-volt supply and an 8-ohm speaker, you can get by with using a

27-ohm series resistor. It will adequately protect the 555, assuming that the circuit is used intermittently.

### Building it

To get the most out of the project, you may want to consider building it on a plug-in type, solderless circuit board such as *Experimenter 300* from Global Specialties, the 276-170 from Radio Shack, or a terminal strip such as AP Products' 217-L. Doing that will let you experiment with the component values.

Nothing is critical about construction. Fig. 2 shows how to duplicate the author's placement of components (see photo) if you use one of the prototype boards mentioned above. ■

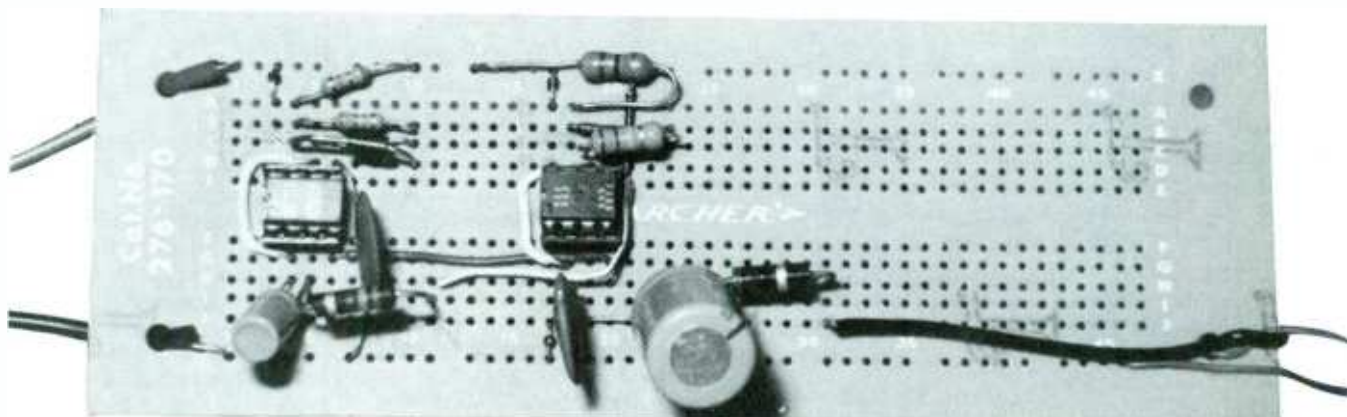

The Hee-Haw siren is hard-wired to a Radio Shack 276-170 printed-circuit board that duplicates the layout shown in Fig. 2. Economy-minded hobbyists can squeeze the parts to the left and cut off the unused portion of the board, saving the excess for another project.

## ELECTRONIC SWITCH

*(Continued from page 93)*

VAC. Should your external circuit that is being switched exceed this rating, use the reed switch to control another relay whose contacts have the desired rating.

While testing the prototype of the Push-on/Push-off Electronic Switch, we thought of a number of possible applications. One was as a replacement for the on-off switch on a

radial-arm power saw. We rejected that on second thought because the circuit was not fail-safe. A component or circuit failure might unexpectedly turn the saw on, creating a possible hazard. One possible use without foreseen dangers could be as a low-voltage remote control for security around the perimeter of the home. Another would be as a "panic button" controlling a siren or other alarm that you might use to scare off a possible intruder. Of course, as a light switch it's perfect. ■

## DIRECT VIDEO TO THE COCO

(Continued from page 70)

the loop is intact, both outputs are monochromatic. When the loop is cut, both outputs are color. A small slide switch connected in place of the wire loop will allow you to select between color and monochromatic output.

### Checkout

Connect the video-output cable (the one with a phono connector) to a standard computer monitor, or to a closed-circuit TV monitor (which won't be as sharp as a computer monitor). Then turn on both the monitor and the computer. If you don't see the usual sign-on display, make certain that the computer is working by connecting the computer's normal RF output to a TV set. If you have a display on the TV but none on the monitor, check the installation of the video

## HANDS-FREE TELEPHONE

(Continued from page 53)

important for the adapter to work properly. Be sure to place the disconnected handset back on-hook.

Disconnect the curly cord from the phone connector and solder the phone connector terminals to their appropriate place on the printed-circuit board. Plug the stereo earphones into the jack, reconnect the curly cord to the phone connector, lift the disconnected handset off-hook, and verify that you can hear the dial tone through the earphones. Break dial tone by punching a digit on the phone. You should hear the DTMF beeping sound. Verify the amplifier's operation by touching a large insulated metal object (like a screwdriver) to the center connection point for the microphone. You should hear power hum. Disconnect everything and place the handset on-hook.

Now assemble the whole telephone adapter. Push the microphone through the grommet from back to front to avoid destroying the microphone's plastic foam front dust cover. Make sure that the microphone is oriented properly, because if it is not connected properly and reverse power is applied to it, it will be destroyed. In order to mount the printed-circuit board, one screw near the mounting hole for the earphone jack will need to be loosened, and partially removed, in order to slip the PC mounted earphone jack through the hole in the front panel. After tightening the earphone jack to the front wall of the telephone adapter, tighten the printed-circuit board down and solder the microphone connections. Slide the phone connector into the slot and put the box lid on. The telephone adapter is ready to use.

### Summary

As you use your telephone adapter, you will note several strikingly enhanced differences between its performance and the performance of your normal telephone. The telephone adapter's microphone is very sensitive and will pick up your voice even if you're across the room. Your voice will sound very clear to the person at the other end of the line, since your speech will not have the severe harmonic distortion generated by a telephone's carbon microphone. Besides a very real advantage of having sound in both of your ears, the earphones will produce very clear sound. You will be able to understand long-distance telephone calls even when the trunk line connection is poor and noisy.

After using your telephone adapter with the lightweight

adapter. If there is no display on the TV, check the installation of the MC1372P IC; make certain that it didn't get reversed end-for-end when it was re-installed.

If the adapter is working, set the monitor's brightness and contrast controls for the best possible display and then optimize the display by adjusting the small trimmer potentiometer on the video adapter. You have gone too far if the monitor display *breaks up* or starts to *roll*. To correct, simply back off on the trimmer potentiometer's adjustment. When you're satisfied with the display, carefully route the adapter's output cables around the reset switch and replace the computer's cover, taking care that the output wires pass through the notch cut in the cabinet. If the video monitor you're using doesn't have a built-in sound amplifier (few do), you can connect the adapter's sound output to any kind of amplifier, though a small battery-powered miniature amplifier—such as those sold by Radio Shack are the most convenient to use. ■

headphones and becoming used to the advantages of hands-free telephone operation, you will find it irksome to return to the burden of the poor-quality old fashioned handset.

The Hands-free Telephone Adapter is an informational project. The individual accepts full liability for his or her own actions and is responsible to comply with all local codes concerning direct connection to the telephone system. Be sure to check with your telephone company.

Hands-Free Telephone Adapter patent-application is in process. The authors are sharing the telephone adaptor's design with you for your own use and enjoyment, but it is not to be used for resale or profit.

As you use your Hands-free telephone Adapter and experience the real advantages of having a hands-free telephone, you will wonder, as the authors did, why wasn't that gadget available before? ■

## BOOKSHELF

(Continued from page 16)

and coordinate conversion, Anglo/Metric conversions, and others.

Osborne/Mcgraww-Hill, 2600 Tenth Street, Berkeley, CA 94710. Paperback, 277 pages, \$15.95.

### New Ways to Use Test Meters

By Robert G. Middleton

This work-saving book brings you scores of practical new ways to solve puzzling electronics troubleshooting problems in both analog and digital circuitry. Using crystal-clear instructions and sharp diagrams, it gives you specific guidelines and step-by-step procedures that enable you to get much more from your meters and other test equipment. What's more, easy-to-read

charts help pinpoint appropriate applications for VOM, TVM, and DVM you can use them to best advantage.

Know-how that enables you to cope with more sophisticated troubleshooting challenges, such as adjusting for both feedback waveform and the internal resistance of high voltage/low current circuits.

Also included are many never-before-published electronics troubleshooting techniques, tricks-of-the-trade, and shortcuts. With those advanced methods at your fingertips, you can quickly pinpoint the defect, measure the parameters, and zero-in on the right conclusions no matter how difficult the problem.

Prentice-Hall, Inc., Englewood Cliffs, NJ 07632. Hard cover, 256 pages, \$21.95. ■

CIRCLE 940 ON  
FREE INFORMATION CARD

## JUNKBOX RF MODULATOR

(Continued from page 80)

If the TV set's screen was fully illuminated, depending on the setting of the brightness and contrast controls, turning the Junkbox RF Modulator on will make the screen dark or bring it to the black level.

Turning the computer on will produce a screen display on the TV set. If your computer is outputting color signals, adjust the TV set's color and tint control for the desired color effect(s).

### More Drive

If the TV color appears to be washed out, the Junkbox RF Modulator probably needs additional drive, which can be obtained by opening resistor R32, the project's video input terminating resistor. Resistor R32 is directly accessible when the TI modulator's cover is removed.

The TI modulator's cover is held in place by friction: but if

you try to pop the cover off you will most likely bend it beyond repair, so remove the cover in small steps. Carefully slide a small knife blade between the modulator's cover and the main case at any corner and pry the cover up just enough to slip a small screwdriver between the two. Do the same at the nearest adjacent corner. Then slip the screwdriver into the space and pry one end up very slightly, and then the other end. When you have enough room slip the screwdriver farther down the case and pry again. After a few *pries* on each side the cover will lift off.

Reach in with a small cutter and cut the lead at the top of the resistor marked R32. (An R32 label is printed on the TI modulator's printed-circuit board and is clearly visible.)

Cut the wire about 1/8-in. from the body of the resistor because you might have to re-install the connection. If eliminating R32 causes the picture to tear, or the LED on the TI modulator to light, there's too much drive and you'll have to tack-solder R32's lead. As a general rule you won't have to cut resistor R32. ■

## TOY ORGAN

(Continued from page 71)

youngsters. If you find it to be too loud, a small-valued resistor may be added in series with the speaker, or the value of C3 can be decreased.

### Building the Organ

Almost any construction technique can be used. Parts can be mounted on a small printed-circuit board or on a solderless circuit board; even point-to-point wiring may be used if you wish. The prototype was done on a solderless breadboard system and the layout used is shown in Fig. 2.

As a point of interest, the manufacturer of the breadboard that the author used (Global) also makes a couple of products that make it easy to preserve your design. One, Global's *EXP-300* experimenter paper, duplicates the holes as found on the breadboard and makes it easy to record your design for future use. The other is printed-circuit board stock (*EXP-300-PC*) that also duplicates the hole pattern of the prototyping board. That makes it quite easy to obtain a permanent version of the design developed on the prototyping board—simply transfer the circuit to the PC board and solder. That eliminates the need to develop a foil pattern for your design.

Since the buttons (keys) will take up a few inches of space on some sort of a panel—the bottom of the cake-tin, for instance—they should be mounted on a separate board. The small speaker can be mounted in one side or end of the enclosure.

When selecting an enclosure and/or mounting the components in it, it is wise to consider the amount of punishment—falls, drops, etc.—that smaller children are prone to subject their toys to and plan accordingly. On the same note, it is a good idea to install some form of protective screening over any opening provided for the speaker. Children love to poke

### PARTS LIST FOR TOY ORGAN

#### SEMICONDUCTOR

U1—555 timer integrated circuit

#### RESISTORS

(All resistors are 1/4-watt, 5%, unless otherwise specified)

R1, R2—100,000-ohm

R3-R10—50,000-ohm, trimmer potentiometer

#### CAPACITORS

C1—.025- $\mu$ F, ceramic disc

C2—.01- $\mu$ F, ceramic disc

C3, C4—50- $\mu$ F, 16-WVDC, electrolytic

#### ADDITIONAL PARTS AND MATERIALS

S1—SPST toggle or slide switch

S2-S9—SPST switch, normally-open, momentary-pushbutton switch

B1—6-volts DC (4 C-cells connected in series)

Breadboard, enclosure, 8-ohm speaker, IC socket, hardware, wire, solder, etc.

things into holes and thus are likely to damage the speaker.

As to the cost of the unit, even if all new components were used, it is hard to imagine spending more than \$10 for the parts. Of course, the use of any available junkbox components will bring that cost down considerably.

With all that this project has going for it, why not make one for your youngster today? If there's no one in your family that would benefit from this project, then surprise a neighbor's little one. After all, it's fun to build. ■

## LOW-POWER POLARITY INVERTER

(Continued from page 92)

capacitors C3 and C4 as shown also are not magical—they just happened to have been handy when we did the prototyping.

The diodes are somewhat critical—to the extent that they

must be of the fast-switching types rather than regular silicon power-supply diodes. The ones shown have been tested and work well. They are not, however, the only ones that can be used.

Here's a test that you can use if you are not sure the diodes you have on hand are suitable: If you can charge C4 to about 7 or 8 volts when powered by a 9-volt supply, then your diodes

(Continued from previous page)

are fine. On the flip-side however, if you can only develop about 1 or 2 volts, if anything, try other diodes.

The use of but one resistor is unusual for 555 circuits, but it was found that the circuit worked every bit as well with the configuration shown in Fig. 1 as it did when using a more conventional circuit. If one is a purist, it is possible the pulses may not be perfect for other uses, but the diodes and capacitors don't seem to mind it. By the way, capacitor C2 is used only to keep pulses from the common power-supply lines. It may not be required in your case and, if used, there is a very

wide latitude of values that may be suitable; almost any value over 5- or 10- $\mu$ F should be fine.

While debugging the circuitry for the prototype, it was found to be quite convenient to connect a light-emitting diode (LED) to the output capacitor, C4, to indicate when voltage was being developed. The brightness of the LED can also be used as a relative indication of the amount of voltage developed. We used a 1000-ohm, 1/4-watt resistor in series to limit the LED's current and protect it. You may want to try a similar scheme. It beats keeping your eye on a meter scale all the time. ■

## EXTENSION TELEPHONE RINGER

(Continued from page 65)

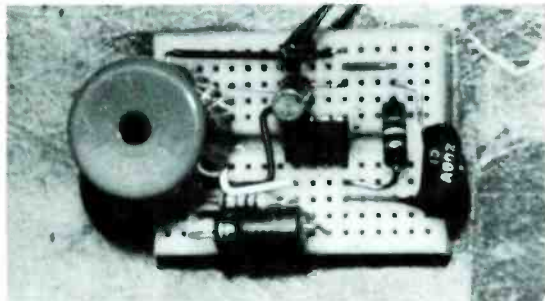

How simple is simple? The photo of the finished product could not be simpler! Only two wires from the telephone circuit connect to the solderless circuit board, and you hear a tone warble when the phone company buzzes your line.

relaxation oscillator. The resistor can range in value from 150,000 to 300,000 ohms while the value of C2 can vary between 400 and 2000 pF. Typically, C2 is 1000 pF for the MC34012-1, 500 pF for the MC34012-2 and 2000 pF for the MC34012-3. Resistor R3 determines threshold of the telephone-line ring-signal voltage needed to produce an output from the transducer. Its value is between 800 and 2000 ohms; depending on voltage level of the ring-signal used by your telephone company. With the value for R3 specified in the schematic diagram, the tone ringer IC is triggered when the ring-signal voltage exceeds 35 volts. Increasing R3's value lowers the triggering threshold.

### Construction

Figure 2 shows how we mounted the parts on a small

### PARTS LIST FOR EXTENSION TELEPHONE RINGER

#### SEMICONDUCTORS

U1—MC34012 telephone tone-ringer (Motorola)

#### RESISTORS

(All resistors are 1/2-watt, 5%)

R1—4700-ohm

R2—180,000-ohm

R3—1800-ohm

#### CAPACITORS

C1—1.0- $\mu$ F, metallized film

C2—.001- $\mu$ F, Mylar

C3—2- $\mu$ F, 10-WVDC, electrolytic

C4—5- $\mu$ F, 25-WVDC, electrolytic

#### ADDITIONAL PARTS AND MATERIALS

PZ1—Piezoelectric transducer (Mallory PT-80; a Radio-Shack 273-064 appears to be a suitable substitute for the transducer specified but we haven't tried it)

Circuit board (A P Products 217-L terminal strip or equivalent, see text), wire, etc.

breadboarding strip. For this project we used 217-L terminal strip from A P Products. We cemented that small ( $1\frac{1}{16} \times 2\frac{3}{4}$  inch) circuit board to a 3-  $\times$  4-inch piece of blank PC board to make handling easier. There is, of course, nothing very critical about the layout, and you can use any other construction technique, such as designing your own PC board and soldering the components in place, if you wish. ■

## EXPERIMENTER'S SHOP

(Continued from page 43)

the transistor (or diode) has unusually high leakage, and if it is capable of functioning: or, more often than not, it will be sufficient information to either service or check electronic devices.

### Tools

Modern circuits and devices often require unusual tools. The need for miniature needlenose pliers and cutters is self-apparent, but have you also considered special installation tools for miniature components? For example, try to pull a DIP integrated circuit from a socket and you're certain to bend or break a few pins. What's needed is a simple and cheap IC puller, a U-shaped device made of spring steel that has hooks at the ends of the U which slip under each end of the IC. Squeeze the U-shaped puller closed and pull straight

up—the IC will be lifted out of the socket without damaging or bending any pins.

Then there's a special installation tool that straightens the pins of DIP IC's, holds the IC in position, and inserts it cleanly into the socket with very little possibility that one or more pins will get turned under and squashed. The tool even has a small ground post to which a ground wire can be clipped when installing CMOS devices. If you're going to handle CMOS devices—which are extremely sensitive to static electricity—either ground yourself with a commercial grounding bracelet, or make one yourself. You can make one from an old watchband and a length of insulated wire that is connected to an electrical ground.

In fact, for extra safety, consider installing a rubberized ground pad such as used for personal computers on your workbench. They go a long way towards protecting against static electricity.

Make certain that your soldering iron is grounded through a 3-wire cord and receptacle. The AC currents flowing in the metal surface of an ungrounded soldering iron can easily zap an IC. Also, consider getting one of the new professional soldering tools, the kind that takes replaceable tips. When working on a high-density printed-circuit board, a fine-needle soldering tip will keep solder off adjacent connections, while a larger tip will give you the extra heat needed to solder to a ground foil. If you can't afford one of the commercial soldering stations, substitute a pencil-thin soldering iron, which is the next best thing. While it might not have sufficient heat for large ground foils, it's the right size for most circuits, and you can always use your old soldering iron when you need extra heat. A 12- to 25-watt iron is the right size for circuit boards; about 40-60 watts for large ground foils and

point-to-point wiring.

No shop is ever complete! There's always a new tool, gadget, or instrument that can be added. Keep in mind that technology is changing so rapidly that today's instruments are almost outmoded by the time you open the packing box. When you're ready to upgrade the shop with high-performance test gear, try to get something with universal application. In this day and age, test gear that's designed for a specific kind of equipment often turns out to be obsolete within a year or two. For example: Even if used with an accessory counter, a variable signal generator is inadequate for testing frequency-programmable AM and FM tuners and radios. So when you're ready to spend big bucks for sophisticated tools or equipment, make certain that they will work with tomorrow's technology. ■

## CALLING ALL HAMS

(Continued from page 86)

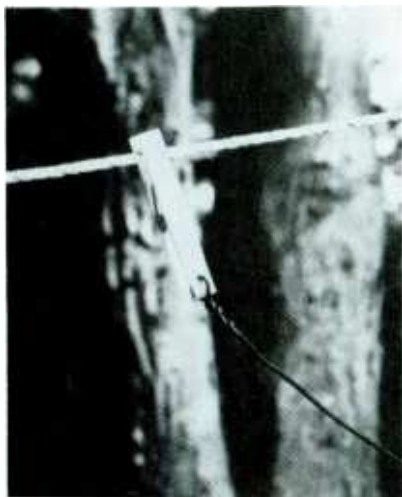

Fig. 5—Plastic clothespin is used to clamp wire add-on to nylon-guy.

Dimensions for the two add-on pairs are given in Fig. 6. A 5-foot, 11-inch add-on in each leg tunes the basic antenna to 15 meters. Frequency of minimum SWR was measured at 21.33 MHz. The second pair of add-ons are 9-foot long and provide operation on two bands, 10 and 75 meters. All of the dimensions given can be varied up and down in such a way that you can establish a minimum SWR on any band-frequency you desire. In the test antenna that was constructed, the minimum SWR frequencies were 28.6 MHz and 3.82 MHz. As mentioned previously, the exact antenna length for a specific frequency also depends on apex angle and height of the antenna ends above ground.

(Continued on page 104)

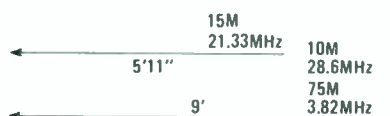

Fig. 6—Add-on dimensions.

## Electronics Paperback Books NEW Paperbacks You'll Want To Read

CHECK OFF THE ONES YOU WANT

**AN INTRODUCTION TO PROGRAMMING THE ATARI 600/800XL...\$5.00.** This text is designed to complement the information supplied by the manufacturer. Essential reading for all Atari owners.

**20 Programs for the ZX Spectrum & 16K ZX81**

**20 PROGRAMS FOR THE ZX SPECTRUM & 16K ZX81...\$5.00.** Included with each program is a detailed flow chart for both games and practical applications in logic, statistics, and engineering.

**BASIC PASCAL IN PARALLEL...\$3.75.** Develops programs in both languages simultaneously. Sample programs illustrate structure.

**30 Solderless Breadboard Projects—Book 2...\$5.75.** 30 more new projects based on CMOS IC's that you can try in minutes on an electronic breadboard.

**MICRO INTERFACING CIRCUITS—Book 1...\$5.75.** In-depth coverage of how the expansion card interface permits the add-on of all kinds to transform a computer into a sophisticated piece of control equipment.

**30 Solderless Breadboard Projects—Book 1**

**HOW TO GET YOUR ELECTRONIC PROJECTS WORKING...\$5.00.** When you can't get that home-built equipment to work, this book may have the answers you need.

**INTERNATIONAL DIODE EQUIVALENTS GUIDE...\$5.75.** Find substitutes when you need them for diodes, triacs, thyristors, OCIs, photodiodes and diode arrays.

**HOW TO Design and Make Your Own PCB's**

**DESIGN & MAKE YOUR OWN PRINTED-CIRCUIT BOARDS...\$5.75.** Everything you ever needed to know about how to make printed circuit boards at home.

**ART OF PROGRAMMING THE 16K ZX81...\$6.25.** What happens when you add the RAM pak. Scrolling, PEEK POKE, Page graphics and more.

**INTERNATIONAL DIODE EQUIVALENTS GUIDE**

**25 SIMPLE AMATEUR BAND ANTENNAS...\$5.00.** Includes designs for dipoles, beams, triangle and even a non-rhombic. Includes a complete set of dimension tables.

**INTERNATIONAL TRANSISTOR EQUIVALENTS GUIDE...\$7.50.** Lists possible substitutes for a particular user-oriented selection of modern transistors. The products of more than 100 manufacturers are included.

**A PRACTICAL INTRODUCTION TO MICRO-PROCESSORS...\$5.00.** The reader will construct his own simple microprocessor circuit and experiment with it to learn more about how microprocessors work.

**EASY ADD-ON PROJECTS FOR SPECTRUM, ZX81...\$7.00.** Pulse detector, picture digitizer, 5-key pad, model controller, key pen and more.

**ELECTRONICS SIMPLIFIED—CRYSTAL SET CONSTRUCTION...\$4.50.** All of these receivers are designed around modern inexpensive components and hand-wound coils.

**30 Solderless Breadboard Projects—Book 2**

**HOW TO GET YOUR ELECTRONIC PROJECTS WORKING**

**ART OF PROGRAMMING THE 16K ZX81**

**INTERNATIONAL DIODE EQUIVALENTS GUIDE**

**25 SIMPLE AMATEUR BAND ANTENNAS**

**EASY ADD-ON PROJECTS FOR SPECTRUM, ZX81**

**ELECTRONICS SIMPLIFIED—CRYSTAL SET CONSTRUCTION**

**30 Solderless Breadboard Projects—Book 1**

**HOW TO GET YOUR ELECTRONIC PROJECTS WORKING**

**ART OF PROGRAMMING THE 16K ZX81**

**INTERNATIONAL DIODE EQUIVALENTS GUIDE**

**25 SIMPLE AMATEUR BAND ANTENNAS**

**EASY ADD-ON PROJECTS FOR SPECTRUM, ZX81**

**ELECTRONICS SIMPLIFIED—CRYSTAL SET CONSTRUCTION**

**A PRACTICAL INTRODUCTION TO MICRO-PROCESSORS**

**DESIGN & MAKE YOUR OWN PRINTED-CIRCUIT BOARDS**

**HOW TO GET YOUR ELECTRONIC PROJECTS WORKING**

**ART OF PROGRAMMING THE 16K ZX81**

**INTERNATIONAL DIODE EQUIVALENTS GUIDE**

**25 SIMPLE AMATEUR BAND ANTENNAS**

**EASY ADD-ON PROJECTS FOR SPECTRUM, ZX81**

**ELECTRONICS SIMPLIFIED—CRYSTAL SET CONSTRUCTION**

**30 Solderless Breadboard Projects—Book 2**

**HOW TO GET YOUR ELECTRONIC PROJECTS WORKING**

**ART OF PROGRAMMING THE 16K ZX81**

**INTERNATIONAL DIODE EQUIVALENTS GUIDE**

**25 SIMPLE AMATEUR BAND ANTENNAS**

**EASY ADD-ON PROJECTS FOR SPECTRUM, ZX81**

**ELECTRONICS SIMPLIFIED—CRYSTAL SET CONSTRUCTION**

**30 Solderless Breadboard Projects—Book 1**

**HOW TO GET YOUR ELECTRONIC PROJECTS WORKING**

**ART OF PROGRAMMING THE 16K ZX81**

**INTERNATIONAL DIODE EQUIVALENTS GUIDE**

**25 SIMPLE AMATEUR BAND ANTENNAS**

**EASY ADD-ON PROJECTS FOR SPECTRUM, ZX81**

**ELECTRONICS SIMPLIFIED—CRYSTAL SET CONSTRUCTION**

**ELECTRONIC TECHNOLOGY TODAY INC.** HOE #3  
P.O. Box 240, Massapequa Park, NY 11762

Number of books ordered

Total Price of Books \_\_\_\_\_

Sales Tax (NY State Residents only) \_\_\_\_\_

Shipping and Handling (75¢ 1 or 2 books 30¢ each add'l book) \_\_\_\_\_

TOTAL ENCLOSED \_\_\_\_\_

Name \_\_\_\_\_

Address \_\_\_\_\_

City \_\_\_\_\_ State \_\_\_\_\_ Zip \_\_\_\_\_

PRICES GOOD UNTIL April 30

## BOOKSHELF

(Continued from page 96)

### Programming Your Commodore 64 in BASIC By Mario J. Eisenbacher

Now that you own the dynamic Commodore 64TM computer, this book is the next investment you should make! It is written in an informal, easy-to-absorb style and requires no previous programming experience to understand its



CIRCLE 990  
ON FREE INFORMATION CARD

contents.

Here, you learn by doing as you work out each program. As you advance through seven levels of computer proficiency, you'll be exposed to customized teaching techniques.

Included in the text are: A new vocabulary, with definitions and explanations of syntax; a step-by-step sample program using the new vocabulary; an interest stimulator (a short, *fancy* program for you to run); practice program; questions and answers; examples of errors and how to handle them—and much more!

Whether you want to learn how to write your own programs for profit or just want to make more intelligent decisions when buying *canned* programs, this hands-on approach will arm you with the skills and working knowledge you need.

Mario Eisenbacher is a project engineer at Westinghouse Electric's Combustion Turbine

Division in Philadelphia and is also a personal computer consultant and director of AstraSoft.

Prentice-Hall, Inc., Englewood Cliffs, NJ 07632. Paperback, 244 pages, \$17.95.

### Music Synthesizers: A Manual of Design & Construction By Delton T. Horn

Looking for an exciting new electronics project? Wishing you could afford a music synthesizer? Tired of trying to find a synthesizer that suits your individual needs? You can have the exact modules you need, position and mark the controls to suit yourself, and expand your synthesizer to as many modules as you can build or afford. Let this unique do-it-yourself manual show you how easy and inexpensive it can be to build your own made-to-order synthesizer!

If you understand basic electronics and can read a

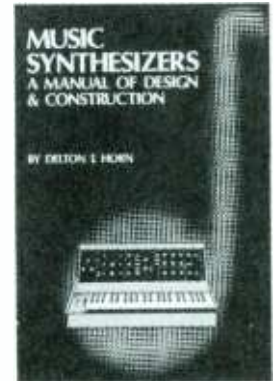

CIRCLE 961  
ON FREE INFORMATION CARD

schematic diagram, you can have fun building your own instrument. Find out about the various types of power-supply circuits, signal sources, voltage-controlled oscillators, amplifiers, filters, and more. Plus, there are dozens of electronic circuits—most which come with complete parts lists—that you can easily build.

TAB Books, Inc., Blue Ridge Summit, PA 17214. Paperback, 343 pages, \$12.50. ■

## This publication is available in microform.



University  
Microfilms  
International

University Microfilms International reproduces this publication in microform: microfiche and 16mm or 35mm film. For information about this publication or any of the more than 13,000 titles we offer, complete and mail the coupon to: University Microfilms International, 300 N. Zeeb Road, Ann Arbor, MI 48106. Call us toll-free for an immediate response: 800-521-3044. Or call collect in Michigan, Alaska and Hawaii: 313-761-4700.

Please send information about these titles:

\_\_\_\_\_

\_\_\_\_\_

Name \_\_\_\_\_

Company/Institution \_\_\_\_\_

\_\_\_\_\_

Address \_\_\_\_\_

City \_\_\_\_\_

State \_\_\_\_\_ Zip \_\_\_\_\_

Phone ( ) \_\_\_\_\_

## DON'T FORGET



USE  
YOUR  
READER  
SERVICE  
CARD

## FRIEDMAN ON COMPUTERS

(Continued from page 67)



Thinkjet, the personal printer from Hewlett-Packard, is available in three different interfaces: HP-IB, HP-IL and Centronics. This 150-cps, ink-jet printer is small and quiet—ideal for home and office text and graphics printing.

when you're all finished adding up the costs you would probably do better with a standard matrix printer. But if you need a lightweight serial thermal, that is the top-of-the-heap.

A more recent addition to the marketplace is Epson's high-performance porta-



The printhead for the H-P Thinkjet personal printer is conveniently disposable and easy to reload. That design technique eliminates the necessity for clearing clogged jets.

ble printer for their Geneva/PX-8 notebook computer, which takes single sheets or puffed paper. (No! Epson has not yet assigned a model number to the printer.) The printer has Centronics and serial inputs, and is powered by a rechargeable-battery or an AC adapter. It provides six type-styles, from 40- to 160-characters per line, along with a bit image mode. Though an 80-column printer, it's small enough and light enough to be taken along with a portable computer.

### Squirt!

A departure from most battery-powered printer designs is Hewlett Packard's Thinkjet printer, which uses a combination disposable ink-bladder/ink-jet printhead. The printer accommodates standard 8½-in.-wide sheets or puffed paper, is available with Centronics, serial or H-P input, and can reproduce the most common Epson or H-P functions and graphics through two software-selected operating modes.

The printhead has 12 microscopic nozzles, which create matrix-like dot-pattern printing. The pictorial shows how the Thinkjet works. As the printhead is driven across the paper, the printer's internal microprocessor creates an electric current

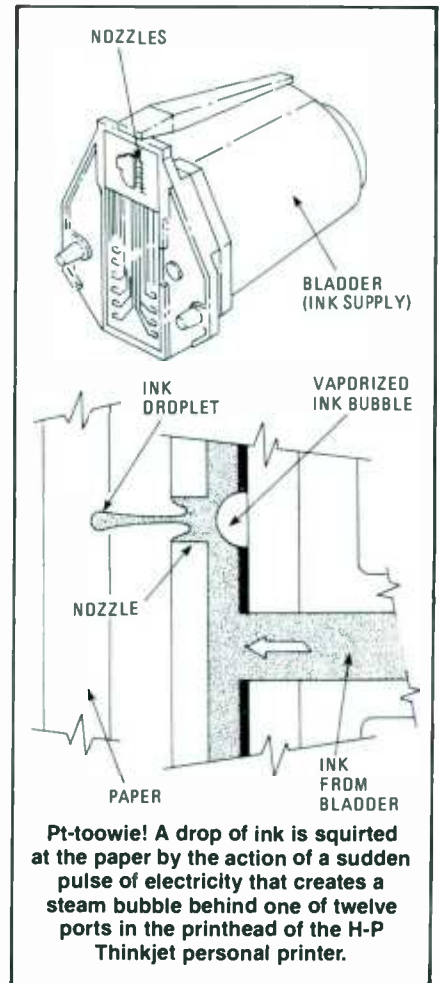

for the nozzles. Whereas that current would normally be used to heat the wires of a thermal printer, in the Thinkjet printer it instantaneously creates a bubble by vaporizing a tiny volume of ink, which gives momentum to the ink in front of the bubble. The only way for the ink to travel is out the nozzle, so a tiny droplet is projected onto the paper. Capillary action refills the nozzle from the bladder.

The bladder contains approximately 3 cc. of ink, which H-P claims is enough to print 500 pages of text. When the ink runs out the user simply pops a complete new printhead (about \$7) into the printer.

Both the thermal and ink-jet printing leaves something to be desired if you're looking for high-quality printing; but if you need something that's small, lightweight, and convenient to use and carry it's amazing how quickly the printing starts to look pretty good.

—Herb Friedman

## GATE/POWER DRIVERS

(Continued from page 89)

output voltage source can be as high as 80 volts. Circuit arrangement is shown in Fig. 5. The solenoid current is 430 milliamperes. That can be handled readily by connecting the two gate/power drivers in parallel. Recall that the maximum

current capability of the paralleled drivers is 1 ampere. Operation can be manual, or, if required, at a clocked rate. Switch S4 is provided for that purpose.

The gate/power driver can be a simple way of doing digital switching at a power level that can operate many peripheral devices directly. Don't forget their capabilities in planning your electronic projects. ■

# Electronics Paperback Books

## Quality Paperbacks at Affordable Prices

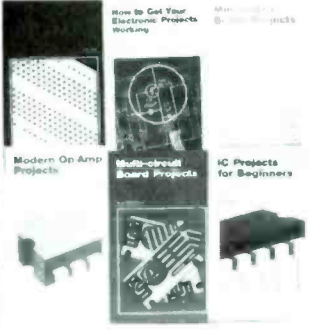
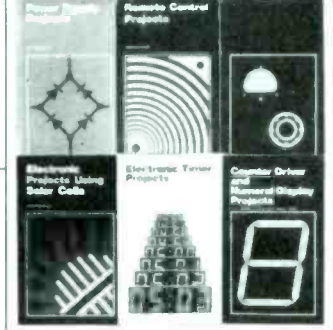
 <p><b>30 SOLDERLESS BREADBOARD PROJECTS BOOK-1.</b> \$5.75. Whenever possible the same parts are used in several projects. Even a first-time builder can complete these circuits.</p> <p><b>HOW TO GET YOUR ELECTRONIC PROJECTS WORKING.</b> \$5.00. Helps you troubleshoot and repair home-built projects of every description.</p> <p><b>MINI-MATRIX BOARD PROJECTS.</b> \$5.00. A variety of projects that can all be built upon a mini-matrix board that has 10 strips and is 24 holes long.</p> <p><b>MODERN OP-AMP PROJECTS.</b> \$5.00. Wide range of specialized op-amp circuits including no-noise, no-distortion, ultra-high input impedance, etc.</p> <p><b>MULTI-CIRCUIT BOARD PROJECTS.</b> \$5.00. 21 fairly simple projects that can all be built on a single printed-circuit board. All are powered by a 9V battery.</p> <p><b>IC PROJECTS FOR BEGINNERS.</b> \$5.00. Inexpensive digital and linear ICs are used to assemble this selection of circuits intended for the beginner.</p>	 <p><b>THE PRE-COMPUTER BOOK.</b> \$5.00. Aimed at the absolute beginner with no knowledge of computers. A non-technical discussion that helps you enter the computer world painlessly.</p> <p><b>THE PRE-COMPUTER BOOK.</b></p> <p><b>AN INTRODUCTION TO VIDEO.</b> \$5.00. Perfect for the person just about to buy a VCR. Discusses pros &amp; cons of the various formats, video discs, videotext, tape copying and more.</p> <p><b>AN INTRODUCTION TO VIDEO.</b></p> <p><b>BASIC &amp; PASCAL.</b> \$4.00. Takes BASIC &amp; Pascal and develops programs in both languages simultaneously.</p> <p><b>FIRST BOOK OF TRANSISTOR EQUIVALENTS &amp; SUBSTITUTES.</b> \$3.75.</p> <p><b>PRACTICAL COMPUTER EXPERIMENTS.</b> \$4.50.</p> <p><b>ART OF PROGRAMMING THE 16K ZX81.</b> \$6.25. Topics include full screen, scrolling, PEEK &amp; POKE, plus actual working programs.</p> <p><b>THE 6809 COMPANION.</b> \$5.00. Written for the average assembly language programmer. A discussion of 6809 features &amp; reference work for the 6809 programmer.</p> <p><b>PRACTICAL COMPUTER EXPERIMENTS.</b> \$4.50. Fills in background to microprocessor by constructing typical computer circuits using discrete logic components.</p> <p><b>ART OF PROGRAMMING THE 1K ZX81.</b> \$5.00. How to use the features of the ZX81 in programs that fit the 1K machine and are still fun to use.</p> <p><b>INTRODUCTION TO BASIC PROGRAMMING TECHNIQUES.</b> \$5.00. Based on author's own experience in learning BASIC and helping others to learn to program.</p> <p><b>A MICROPROCESSOR PRIMER.</b> \$4.50. Plainest approach to computing for the beginner. Step-by-step explains computer operations and assembly.</p>	 <p><b>ELECTRONICS SIMPLIFIED CRYSTAL SET CONSTRUCTION.</b> \$4.50.</p> <p><b>ELECTRONIC HOUSEHOLD PROJECTS.</b> \$4.50.</p> <p><b>PRACTICAL ELECTRONIC BUILDING BLOCKS—Book 1.</b> \$5.00. All electronics circuits consist of simple building blocks. When you know how to make the blocks you can easily create your own projects.</p> <p><b>PRACTICAL ELECTRONIC BUILDING BLOCKS—Book 2.</b> \$5.00. Circuits that process signals; Combines with those in Book 1.</p> <p><b>ANTENNA PROJECTS.</b> \$5.00. Covers critical antenna designs including active, loop &amp; ferrite types that are easy &amp; inexpensive to build.</p> <p><b>RADIO STATIONS GUIDE.</b> \$4.75. Comprehensive listing of transmitters around the world. Presents location, frequency, power.</p> <p><b>LONG DISTANCE TV RECEPTION (TVDX) FOR THE ENTHUSIAST.</b> \$5.00. Practical &amp; authoritative introduction to this unusual aspect of electronics.</p> <p><b>CB PROJECTS.</b> \$5.00. A number of useful and interesting designs for CB accessories. Speech processor, interference filter &amp; more.</p> <p><b>CRYSTAL SET CONSTRUCTION.</b> \$4.50. Packed full of easy to duplicate designs for crystal radio receivers.</p> <p><b>AN INTRODUCTION TO RADIO DX'ING.</b> \$5.00. Listen in your home, to broadcasts originating thousands of miles away. Tells how you can do it.</p>	 <p><b>POWER SUPPLY PROJECTS.</b> \$4.50. Contains designs and construction details for almost any power supply the experimenter is likely to need.</p> <p><b>REMOTE CONTROL PROJECTS.</b> \$5.00. Radio-control infrared, visible light, &amp; ultrasonic systems are all included, along with methods of applying them.</p> <p><b>ELECTRONIC TEST EQUIPMENT CONSTRUCTION.</b> \$4.50. Construction details of a wide range of test equipment the experimenter can build at home.</p> <p><b>ELECTRONIC TIMER SOLAR CELLS.</b> \$5.00. Simple circuits that have numerous applications around the home.</p> <p><b>ELECTRONIC TIMER DISPLAY PROJECTS.</b> \$4.50. Features applications &amp; projects using various types of numerical-display devices.</p> <p><b>COUNTER DRIVER &amp; NUMERICAL-DISPLAY PROJECTS.</b> \$4.50. Features applications &amp; projects using various types of numerical-display devices.</p>
 <p><b>PRACTICAL ELECTRONIC BUILDING BLOCKS—Book 1.</b> \$5.00. All electronics circuits consist of simple building blocks. When you know how to make the blocks you can easily create your own projects.</p> <p><b>PRACTICAL ELECTRONIC BUILDING BLOCKS—Book 2.</b> \$5.00. Circuits that process signals; Combines with those in Book 1.</p> <p><b>HOW TO MAKE WALKIE TALKIES.</b> \$5.00. Describes equipment for low-power handheld operation. 112 pages of must reading for the dedicated experimenter.</p> <p><b>ELECTRONIC CALCULATOR USERS HANDBOOK.</b> \$3.95. Presents formulae, data, methods of calculation, conversion factors &amp; more from the view of the calculator user.</p> <p><b>LINEAR IC EQUIVALENTS AND PIN CONNECTIONS.</b> \$8.25. Shows equivalents &amp; pin connections of a popular user-oriented selection of linear ICs.</p> <p><b>INTERNATIONAL DIODE EQUIVALENTS GUIDE.</b> \$5.75. Helps you find substitutes for the many different types of semiconductor diodes in use today.</p> <p><b>INTERNATIONAL TRANSISTOR EQUIVALENTS GUIDE.</b> \$7.50. Products of more than 100 manufacturers are listed &amp; cross-referenced with possible replacements.</p>	 <p><b>SPECIAL OFFER Book 1 &amp; Book 2 PRACTICAL ELECTRONIC BUILDING BLOCKS.</b> \$9.00. Shipping Included. Save \$1.75.</p> <p><b>RADIO CONTROL FOR BEGINNERS.</b> \$4.50.</p> <p><b>ELECTRONIC GAMES.</b> \$4.50.</p> <p><b>SINGLE IC PROJECTS.</b> \$4.25.</p> <p><b>RADIO CIRCUITS USING IC'S.</b> \$4.50.</p> <p><b>ELECTRONIC HOUSEHOLD PROJECTS.</b> \$4.50.</p> <p><b>ELECTRONIC MUSIC PROJECTS.</b> \$4.50.</p> <p><b>POPULAR ELECTRONIC PROJECTS.</b> \$3.75.</p> <p><b>PROJECTS IN OPTO-ELECTRONICS.</b> \$5.00.</p>	 <p><b>ANTENNA PROJECTS.</b> \$5.00. Covers critical antenna designs including active, loop &amp; ferrite types that are easy &amp; inexpensive to build.</p> <p><b>RADIO STATIONS GUIDE.</b> \$4.75. Comprehensive listing of transmitters around the world. Presents location, frequency, power.</p> <p><b>LONG DISTANCE TV RECEPTION (TVDX) FOR THE ENTHUSIAST.</b> \$5.00. Practical &amp; authoritative introduction to this unusual aspect of electronics.</p> <p><b>CB PROJECTS.</b> \$5.00. A number of useful and interesting designs for CB accessories. Speech processor, interference filter &amp; more.</p> <p><b>CRYSTAL SET CONSTRUCTION.</b> \$4.50. Packed full of easy to duplicate designs for crystal radio receivers.</p> <p><b>AN INTRODUCTION TO RADIO DX'ING.</b> \$5.00. Listen in your home, to broadcasts originating thousands of miles away. Tells how you can do it.</p>	 <p><b>THE SIMPLE ELECTRONIC CIRCUIT &amp; COMPONENTS.</b> \$5.75. All the fundamental theory needed to lead to a full understanding of the simple electronic circuit and its components.</p> <p><b>ALTERNATING CURRENT THEORY.</b> \$5.75. Alternating current theory without which there can be no comprehension of speech, music, radio, or Television.</p> <p><b>MICROPROCESSING SYSTEM &amp; CIRCUITS.</b> \$7.50. A truly comprehensive guide to all of the elements of a microprocessing system.</p> <p><b>SOLID STATE NOVELTY CIRCUITS.</b> \$3.50.</p> <p><b>28 TESTED TRANSISTOR PROJECTS.</b> \$4.25.</p> <p><b>SEMICONDUCTOR TECHNOLOGY.</b> \$5.75. Everything you always needed to know about solid-state devices in one volume.</p> <p><b>COMMUNICATIONS.</b> \$7.50. Covers most modern communication systems. Line, microwave, submarine, satellite, digital, multiplex, radio &amp; telegraphy.</p> <p><b>FIRST BOOK OF HI-FI SPEAKER ENCLOSURES.</b> \$4.50.</p>

ELECTRONIC TECHNOLOGY TODAY INC.  
P.O. Box 240, Massapequa Park, NY 11762

HO2 10/84

Number of books ordered

Total Price of Books ..... \$ .....

Sales Tax (NY State Residents) .....

Shipping (75¢ 1st two books, 30¢ ea additional) .....

TOTAL ENCLOSED ..... \$ .....

Name .....

Address .....

City ..... State ..... ZIP .....



## SAXON ON SCANNERS

(Continued from page 91)

peaters, plus many of the 150-MHz band police transmissions. Repeaters are so heavily used these days, it's well to have a basic knowledge of their operation in order to fully appreciate how they fit into your monitoring efforts.

### Mailbag

Our Mailbag for this issue shows a letter from Archie Covington of Indiana. Archie asks if there are any specific frequencies normally used for fire and crash-truck use at various military and civilian airports. Civilian airports often have their fire departments operating on the same frequency (or frequencies) used by all area fire departments; however, the trucks may also operate on 122.775 and 122.85 MHz for communications with aircraft while the vehicles are operating on airport ramp areas. Many Naval Air Stations operate crash-trucks on 140.10 MHz, while the U.S. Air Force often uses 173.585 MHz for that purpose.

Gene *Please-don't-print-my-last-name* of Opa Locka, FL asks another aeronautical communications question. He wants to know where on his scanner to listen for the Civil Air Patrol, the Auxiliary of the U.S. Air Force. CAP communications take place on 148.15 and 149.925 MHz. During SARCAP's (Search/Rescue missions) the CAP stations can also be heard on 123.1 MHz.

Louis Arnault says he has heard weak transmissions on 163.815 MHz which seem to be law-enforcement related, although local Newark, NJ police operate on other channels nowhere near that frequency. He wants to know if we can put on our thinking cap and give him some idea of what that is. Here's our guess: The specific frequency being monitored is most likely 163.8125 MHz, which is an uplink frequency used nationally by U.S. marshals to access their repeaters operating on 163.20 MHz. Try tuning your scanner to 163.20 MHz and you'll probably hear the same transmissions but with considerably better quality. That frequency is probably active in most areas of the United States, at least wherever the U.S. marshals are functioning.

"There are sometimes transmissions being monitored on 35.005 MHz," reports Lon Harris of Chila Vista, CA. "Only problem," says Lon, "is that that frequency doesn't appear to be assigned to any specific radio service." Essentially, Lon wants to know what type of station might use such a strange frequency. That frequency and several others have been set aside by the FCC for by communications stations performing special developmental work. That could include stations devising new or unique applications for communications services or



American Military communications sometimes skip into the U.S. when radio-frequency propagation conditions are just right. (U.S. Army Photo)

equipment. From time to time those stations offer some curious and out of the ordinary listening fare, although the frequencies are not in heavy use. Listen on the following frequencies for those stations: 30.565, 31.995, 33.005, 33.995, 35.005, 35.995, 37.005, 37.995, 39.005, 39.995, 42.005 Mhz.

Alice Brannigan of Boston, MA reports that during a recent trip to Wilkes Barre, PA she noted weather broadcasts on the rather unusual frequency of 167.905 MHz. She says that a check with the NOAA office revealed that that frequency is a radio link from the NOAA office to the remote 162.55-MHz weather-

## Radio-Electronics REPRINT BOOKSTORE

- |  |  |
|--|--|
| <input type="checkbox"/> Build Your Own Satellite TV Receiver ..... \$7.00 | <input type="checkbox"/> Special Projects (Spring 1981) ..... \$4.50             |
| <input type="checkbox"/> 8-Ball Satellite TV Antenna ..... \$5.00          | <input type="checkbox"/> Special Projects #4 (Summer 1982) ..... \$4.50          |
| <input type="checkbox"/> Build Your Own Robot ..... \$12.00                | <input type="checkbox"/> Special Projects #5 (Winter 1983) ..... \$4.00          |
| <input type="checkbox"/> TV Descrambler (January, February 1981) \$3.00    | <input type="checkbox"/> Special Projects #6 (Spring 1983) ..... \$4.00          |
| <input type="checkbox"/> Radio-Electronics back issues (1984) ..... \$3.00 | <input type="checkbox"/> Special Projects #7 (Summer 83) NOT AVAILABLE           |
| <input type="checkbox"/> Radio-Electronics back issues (1983) ..... \$3.50 | <input type="checkbox"/> Special Projects #8 (Fall 83) ..... \$4.00              |
| (January, February 1983 not available)                                     | <input type="checkbox"/> Special Projects #10 (Spring 84) ..... \$4.00           |
| Write in issues desired.....   | <input type="checkbox"/> Radio-Electronics Annual 1983 ..... \$3.50              |
| <input type="checkbox"/> Radio-Electronics back issues (1982) ..... \$3.50 | <input type="checkbox"/> Radio-Electronics Annual 1984 ..... \$2.50              |
| Write in issues desired.....   | <input type="checkbox"/> How to Make PC Boards ..... \$2.00                      |
| <input type="checkbox"/> Radio-Electronics back issues (1981) ..... \$4.00 | <input type="checkbox"/> All About Kits ..... \$2.00                             |
| (Jan., Feb., March, Dec. 1981 not available)                               | <input type="checkbox"/> Modern Electronics (Vol. 1, #1 April 1908) ..... \$2.25 |
| Write in issues desired.....   | <input type="checkbox"/> Electro Importing Co. Catalog ..... \$4.95              |
| <input type="checkbox"/> Etch your own PC boards ..... \$3.00              | (1918) (176 pp)  |
| <input type="checkbox"/> Hands On Electronics #1 ..... \$3.00              | <input type="checkbox"/> Low Frequency Receiving Techniques ..... \$6.00         |
| <input type="checkbox"/> RE Annual '85 ..... \$2.50                        | Building and using VLF Antennas  |

To order any of the items indicated above, check off the ones you want. Complete the order form below, include your payment, check or money order (DO NOT SEND CASH), and mail to Radio-Electronics, Reprint Department, 200 Park Ave South, New York, NY 10003. Please allow 4-6 weeks for delivery.

If you need a copy of an article that is in an issue we indicate is unavailable you can order it directly from us. We charge 50¢ per page. Indicate the issue (month & year), pages and article desired. Include payment in full, plus shipping and handling charge.

ARTICLE \_\_\_\_\_

PAGES \_\_\_\_\_ MONTH \_\_\_\_\_ YEAR \_\_\_\_\_

TOTAL PAGES \_\_\_\_\_ @ 50¢ each TOTAL PRICE \_\_\_\_\_

### MAIL TO Radio-Electronics

Reprint Department, 200 Park Ave South, New York, NY 10003

HOE # 3 All payments must be in U.S. funds

Total price of order	\$ _____
Sales Tax (New York State Residents only)	\$ _____
Shipping & Handling (U.S. & Canada only) (Includes FIRST CLASS POSTAGE) \$1.00 per item	\$ _____
All other countries (\$2.00 per item, sea mail)	\$ _____
(\$4.00 per item, air mail)	\$ _____

Total Enclosed \$ \_\_\_\_\_

Name \_\_\_\_\_

Address \_\_\_\_\_

City \_\_\_\_\_ State \_\_\_\_\_ Zip \_\_\_\_\_

broadcast transmitter. Nice catch, Alice! Let's hear from you again.

Carleton R. of Watertown, NY advises that the Canadian immigration patrols can be monitored on 42.54 MHz and asks if we know the frequencies used by the American immigration patrols. Carl, take-a-listen on the following frequencies, as they seem to be popularly used along the borders: 162.925, 163.625, 163.675, 165.975, 168.825, and 170.675 MHz.

Albert Markowitz of Reno, NV writes to say that sometimes skip conditions are just right, and that he's able to pick up stations overseas on his scanner. He particularly notes that on 33.35 MHz he has heard infantry communications from

American troops who appear to be engaged in maneuvers. We heard that a few times, too. Al, and it seems to be a repeater set to pick up low-power communications on some other frequency and retransmit them via higher power. Apparently that is connected with American military maneuvers which sometimes take place in Central America. Other frequencies which have produced American Military Communications from overseas during skip periods include: 30.00, 30.05, 30.10, 30.45, 30.55, 30.90, 31.45 and 33.10 MHz. There are plenty more too, plus a bunch of radio paging stations in South America to be monitored between 30 and 35 MHz when RF propagation conditions are just right.

Since, we have just about run out of space for this issue's column, so we'll close with this question from Sam Barton of Penbrook, PA. Sam wants to know if we can come up with the Pennsylvania State Liquor and Drug Control Agency frequencies. You betcha, *hic!* The frequency used by the Liquor Control Board folks is 45.30 MHz, while the drug-control operations take place on 154.905, 154.95, 155.455, and 155.49 MHz.

Why not pass along any tips or questions, photos, or other comments relating to scanners and scanning. Write to me, Mark Saxon, **Hands-On Electronics**, 200 Park Avenue South, New York, NY 10003. Looking forward to hearing from you!  
—Marc Saxon

## STEREO POWER METER

(Continued from page 36)

the copper foil is in good condition and that there are no solder bridges that you may have overlooked. If you still can't locate the problem, check the electrolytic capacitors to be sure that the positive lead of each in the correct hole and check the diodes to be sure that are not mounted backward. Look for cold solder joints.

You may also check for resistors being discolored, or cracked, or that show signs of bulging. Those symptoms usually mean faulty wiring rather than a defective resistor and you should find the cause for overheating before replacing the resistor. Check to be sure that none of the leads from the

components are shorting out against some other part of the unit. If, after going through that whole procedure, you are still unable to find the problem, it may be in the chips themselves. It is possible that the chips are not seated properly or that a pin is folded under the chip. Also look to be sure that the chip's pins are in their proper holes. If the chips are positioned properly, you may have damaged them in some way without being aware of it—in which case they must be replaced.

If the brightness of a few LED's is the only problem, it's possible that those diodes are defective and are not passing the signal properly. If so, replace them. Finally, if the unit is operational but the response of the LED's is slow, you may want to try replacing C2 and C3 with other capacitors. ■

## CALLING ALL HAMS

(Continued from page 99)

Table 1 shows a list of practical equations based on the theoretical formula for leg lengths that resonate on multiples of a 1/4-wavelength for long-wire antennas. All you need to do is to divide the K value given by the desired frequency in mega-Hertz to obtain the recommended length in feet. Values given are only a starting point. You may need to cut and try the antenna leg lengths until your particular antenna installation resonates at the desired frequency. Don't forget that you need to cut two such lengths to complete your antenna.

### Antenna Tuner

As the antenna wire is increased in electrical wavelength there is a gradual rise in the antenna resistance. Consequently, the antenna will not provided a precise match

## NEW PRODUCTS

(Continued from page 95)

button operation, and includes a tuner with automatic search tuning and 8 presets per band.

The R-102 has a suggested retail price of \$499.00. Available at better audio shops nationwide. ■

to the transmission line. However, minimum SWR values are seldom above 2.5-to-1. For most transmitters a 1.5-to-1 ratio is not objectionable. My own transmitter, with its vacuum-tube output stage, can match from 50 up to 200 ohms and deliver rated output. Those transmitters with solid-state outputs are usually more critical of match, outputs dropping off significantly with mismatch.

A mismatch situation is avoided with the use of an antenna tuner. Remember that a tuner *never* improves the antenna performance; however, it does make certain that the transmitter sees a proper load. A combination of a correctly tuned antenna and a tuner to match your transmitter is the preferred way to go when your transmitter is critical of the output impedance it sees. Wise tuner-use will be covered in a future column.  
Keep tuned in. ■

## ADVERTISING INDEX

**HANDS-ON ELECTRONICS** magazine does not assume any responsibility for errors that may appear in the index below.

Free Information No.	Page
908	Accessory Specialists ..... 16
914	All Electronics ..... 8
905	AMC Sales ..... 6
917	B.D.&R. Enterprises ..... 14
907	Brunelle Instruments ..... 15
---	C.I.E. .... 29
918	Command Productions ..... 12
908	Digi-Key ..... 4,5
---	Electronic Book Club ..... 3
920,921	Electronic Warehouse ..... 10,11
---	ETT ..... 94,99
---	Fluke ..... Cover IV
910	Galaxy ..... 6
922	Halted ..... 16
912	Health ..... 20
---	I.C.S. .... 14
913	Jameco ..... Cover II
906	Mouser ..... 12
---	NRI ..... 19
---	NTS ..... 39
924	Phillips Tech. .... 15
911	Radio Shack ..... 7
---	RE Bookstore ..... 103
---	Tektronics ..... Cover III

# BUY BONDS

TABLE 1

Antenna Leg	K
1/4 λ	234
3/4 λ	725
5/4 λ	1220
7/4 λ	1710

$$\text{Leg Length (Ft)} = \frac{K}{f - (\text{MHz})}$$

7400

74F00

NEW

74ALS00

Digitalker™

Table with 4 columns: Part No., Pcs, Price, Part No., Pcs, Price. Lists various 7400 series components like inverters, buffers, and logic gates.

Table with 4 columns: Part No., Pcs, Price, Part No., Pcs, Price. Lists various 74F00 series components.

Table with 4 columns: Part No., Pcs, Price, Part No., Pcs, Price. Lists various 74ALS00 series components.

Table with 4 columns: Part No., Pcs, Price, Part No., Pcs, Price. Lists various 74ALS00 series components.

Table with 4 columns: Part No., Pcs, Price, Part No., Pcs, Price. Lists various 74ALS00 series components.

Table with 4 columns: Part No., Pcs, Price, Part No., Pcs, Price. Lists various 74ALS00 series components.

Table with 4 columns: Part No., Pcs, Price, Part No., Pcs, Price. Lists various 74ALS00 series components.

Table with 4 columns: Part No., Pcs, Price, Part No., Pcs, Price. Lists various 74ALS00 series components.

DT1050 — Applications: Teaching aids, appliances, clocks, automotive, telecommunications, language translations, etc.

DT1050 consists of a Speech Processor Chip, MM54104 (40-pin) and two 25-pin ROMs MM54164 and MM54165 (24-pin).

DT1050 Digitalker™ \$34.95 ea. MM54104 Processor Chip \$14.95 ea.

DT1057 — Expands the DT1050 vocabulary from 137 to over 260 words. Includes 2 ROMs and specs.

DT1057 \$24.95 ea.

INTEGRIS

Table with 4 columns: Part No., Pcs, Price, Part No., Pcs, Price. Lists various INTEGRIS components like ROMs, RAMs, and logic chips.

30009 1983 INTEGRIS Data Book (136 p.) \$9.95

74HC CMOS High Speed CMOS

Table with 4 columns: Part No., Pcs, Price, Part No., Pcs, Price. Lists various 74HC CMOS components.

74C-C/MOS

Table with 4 columns: Part No., Pcs, Price, Part No., Pcs, Price. Lists various 74C-C/MOS components.

LINEAR

Table with 4 columns: Part No., Pcs, Price, Part No., Pcs, Price. Lists various LINEAR components.

DATA ACQUISITION

Table with 4 columns: Part No., Pcs, Price, Part No., Pcs, Price. Lists various DATA ACQUISITION components.

WIRE SOCKETS

Table with 4 columns: Part No., Pcs, Price, Part No., Pcs, Price. Lists various WIRE SOCKETS components.

HEADERS

Table with 4 columns: Part No., Pcs, Price, Part No., Pcs, Price. Lists various HEADERS components.

Table with 4 columns: Part No., Pcs, Price, Part No., Pcs, Price. Lists various 7400 series components.

Table with 4 columns: Part No., Pcs, Price, Part No., Pcs, Price. Lists various 74ALS series components.

Table with 4 columns: Part No., Pcs, Price, Part No., Pcs, Price. Lists various 74ALS series components.

Table with 4 columns: Part No., Pcs, Price, Part No., Pcs, Price. Lists various 74ALS series components.

Table with 4 columns: Part No., Pcs, Price, Part No., Pcs, Price. Lists various 74ALS series components.

Table with 4 columns: Part No., Pcs, Price, Part No., Pcs, Price. Lists various 74ALS series components.

Table with 4 columns: Part No., Pcs, Price, Part No., Pcs, Price. Lists various 74ALS series components.

Table with 4 columns: Part No., Pcs, Price, Part No., Pcs, Price. Lists various 74ALS series components.

Table with 4 columns: Part No., Pcs, Price, Part No., Pcs, Price. Lists various 74ALS series components.

Table with 4 columns: Part No., Pcs, Price, Part No., Pcs, Price. Lists various 74ALS series components.

Table with 4 columns: Part No., Pcs, Price, Part No., Pcs, Price. Lists various 74ALS series components.

Table with 4 columns: Part No., Pcs, Price, Part No., Pcs, Price. Lists various 74ALS series components.

Table with 4 columns: Part No., Pcs, Price, Part No., Pcs, Price. Lists various 74ALS series components.

Table with 4 columns: Part No., Pcs, Price, Part No., Pcs, Price. Lists various 74ALS series components.

Table with 4 columns: Part No., Pcs, Price, Part No., Pcs, Price. Lists various 74ALS series components.

Table with 4 columns: Part No., Pcs, Price, Part No., Pcs, Price. Lists various 74ALS series components.

Table with 4 columns: Part No., Pcs, Price, Part No., Pcs, Price. Lists various 74ALS series components.

Table with 4 columns: Part No., Pcs, Price, Part No., Pcs, Price. Lists various 74ALS series components.

Table with 4 columns: Part No., Pcs, Price, Part No., Pcs, Price. Lists various 74ALS series components.

Table with 4 columns: Part No., Pcs, Price, Part No., Pcs, Price. Lists various 74ALS series components.

Table with 4 columns: Part No., Pcs, Price, Part No., Pcs, Price. Lists various 74ALS series components.

Table with 4 columns: Part No., Pcs, Price, Part No., Pcs, Price. Lists various 74ALS series components.

Table with 4 columns: Part No., Pcs, Price, Part No., Pcs, Price. Lists various 74ALS series components.

Table with 4 columns: Part No., Pcs, Price, Part No., Pcs, Price. Lists various 74ALS series components.

Table with 4 columns: Part No., Pcs, Price, Part No., Pcs, Price. Lists various 74ALS series components.

Table with 4 columns: Part No., Pcs, Price, Part No., Pcs, Price. Lists various 74ALS series components.

Table with 4 columns: Part No., Pcs, Price, Part No., Pcs, Price. Lists various 74ALS series components.

310.00 Minimum Order — U.S. Funds Only. Includes Add'l Postage, Sales Tax, Shipping — Add \$5.00. In-Stock Items Ship Same Day. For Monthly sales flyer!

MasterCard, VISA, 1355 SHOREWAY ROAD, BELMONT, CA 94002, 215 PHONE ORDERS WELCOME — (415) 592-8097 Telex: 176043

CIRCLE 913 ON FREE INFORMATION CARD



# Take home a world champion.

**\$85\*** gets you a technical knockout.  
**The Fluke 70 Series.**

**Winners of the digital vs. analog bat-**

Since their debut, they've become the worldwide champions of the industry.

Never before have such tough, American-made meters offered so many professional features at such unbeatable prices.

Each comes with a 3-year warranty, 2,000-hour battery life, and instant autoranging.

You also get the extra resolution of a 3200-count LCD display, plus a responsive analog bar graph for quick visual checks of continuity, peaking, nulling and trends.

Choose from the Fluke 73, the ultimate in simplicity. The feature-packed Fluke 75. Or the deluxe Fluke 77, with its own protective holster and unique "Touch Hold" function\*\* that captures and holds readings, then beeps to alert you.

So don't settle for just a contender. Take home a world champion.

For your nearest distributor or a free brochure, call toll-free anytime  
**1-800-227-3800, Ext. 229.** From outside the U.S., call 1-402-496-1350, Ext. 229.

**FROM THE WORLD LEADER  
IN DIGITAL MULTIMETERS.**



FLUKE 73	FLUKE 75	FLUKE 77
\$85*	\$99*	\$129*
Analog/digital display	Analog/digital display	Analog/digital display
Volts, ohms, 10A, diode test	Volts, ohms, 10A, mA, diode test	Volts, ohms, 10A, mA, diode test
Autorange	Audible continuity	Audible continuity
0.7% basic dc accuracy	Autorange/range hold	"Touch Hold" function
2000+ hour battery life	0.5% basic dc accuracy	Autorange/range hold
3-year warranty	2000+ hour battery life	0.3% basic dc accuracy
	3-year warranty	2000+ hour battery
		3-year warranty
		Multipurpose holster

\* Suggested U.S. list price, effective July 1, 1984.

\*\* Patent pending.

